

FAUNA PASSAGES

Maintaining and restoring
the ecological network with
linear transport infrastructure



Fauna passages

Maintaining and restoring
the ecological network with
linear transport infrastructure

Cerema

Centre d'études et d'expertise sur les risques, l'environnement, la mobilité et l'aménagement
Head office: cité des mobilités – 25, avenue François Mitterrand – CS 92 803 – F-69674 Bron Cedex
www.cerema.fr

The "References" series

This series is a collection of stable, approved reference documents covering the latest practice and research in Cerema's areas of expertise (methodological recommendations, technical rules, expertise, etc.). Intended for both generalists and specialists, it is written in an educational, pragmatic manner to enable professionals to take ownership of, and apply, the recommendations in practice.

Acknowledgements

This collective work by Cerema was led by François Nowicki (Cerema).

It was completed in conjunction with the Ministry of Ecological Transition and in particular the Directorate General for Infrastructure, Transport and the Sea (DGITM), the Directorate General for Planning, Housing and Nature (DGALN) and the Sustainable Development Commission (CGDD).

It was drafted by:

Géraldine Audié-Liebert, Virginie Billon, Jean-François Bretaud, Éric Guinard, Éric Le Mitouard, François Nowicki, Laurence Thuillier of Cerema.

The following also contributed:

Emilie Busson (Cerema), Luc Chrétien (Cerema), Julian Pichenot (Cerema), Delphine Souillot (Cerema), Jean Carsignol (working at Cerema at the time), Pascal Fournier (Groupe de Recherche et d'Etudes pour la Gestion de l'Environnement (GREGE)), Vincent Vignon (Office de génie écologique (OGE)).

Thanks go to the following proofreaders (all or part of the document):

Marine Arzur (Direction régionale de l'environnement, de l'aménagement et du logement (DREAL) Grand Est), Jérôme Bacquaert (Conseil départemental (CD) 62), Caryl Buton (Cabinet X-AEQUO), Philippe Chavaren (VINCI Autoroutes), Luc Chrétien (Cerema), Annabelle Cluzeau (Ministry of Ecological Transition (MTES)/Directorate General for infrastructure, transport and the sea (DGITM))/Direction des infrastructures de transport (DIT)), Benoit Fabien (ministry of Ecological Transition, Sustainable Development Commission (CGDD)), Pascal Fournier (GREGE), Marc Gigleux (Cerema), Claude Guillet (Cerema), Éric Gardais (MTES/DGITM/DIT), Elvire Henry (MTES/DGITM/DIT), Elryck Josset (MTES/DGITM/DIT), Alexandre Kavaj (MTES/DGITM/DIT), Antoine Lombard (MTES/Directorate General for Planning, Housing and Nature (DGALN)/Directorate of water and biodiversity (DEB)), Marine Le Lay (SNCF Réseau), Manuel Le Moine (SNCF Réseau), Sophie Marty-Le-Ridant (Société des autoroutes du Nord et de l'Est de la France (SANEF)), Marie Masson (Société française pour l'étude et la protection des mammifères (SFPEM)), Alain Morand (Cerema), Grégoire Palièrse (DREAL Grand Est), Christophe Pineau (Cerema), Yves Urbain (AREA, groupe Autoroutes Paris-Rhin-Rhône (APRR)), Sylvie Vanpeene (Institut national de la recherche agronomique (INRAE), Vincent Vignon (OGE), Magali Perrin (Mayenne Nature Environnement), Loïc Pianfetti (SNCF Réseau), Sylvain Richard (Office français de la biodiversité (OFB)), Thomas Schwab (Cerema), Franck Simmonet (Groupe mammalogique Breton).

Thanks also to:

Jérôme Albaret (Cerema), Denis Allard (Parc naturel régional du Marais Poitevin), Laurent Arcelin (CD57), Martine Barrandon (JBS Métallerie), Barb Beasley (Association of Wetland Stewards for Clayoquot and Barkley Sounds), Steve Béga (WILDLIFE FENCING & MITIGATION SOLUTIONS), Adel Ben Salem (DIR Est), Xavier Bonnet (CNRS - Centre d'études biologiques de Chizé), Michel Bramard (OFB), Vincent Brun (Cerema), Guillaume Bruno (DIR Est), Christian Bulle (CD 25), Mélody Chantoiseau (Town council of Chamblais-lès-Tours), Céline Coudurier (Autoroutes et tunnel du Mont-Blanc (ATMB)), Stéphane Couret (AquaTera Solutions), Anne-Sophie Croyal (CD 38), Virginie Cuaz (Cerema), Éric Delaye (Cerema), Anne-Claire De Rouck (Cerema), Mégane Desmoutiere (Fédération des chasseurs de Haute-Savoie), Sébastien Fauré (Eurovia Cognac TP), Anthony Février (Bonna Sabla), Thibaut François (Métropole du Grand Nancy), Ludovic Gacek (APRR), Nicolas Georges (Cerema), Gérard Goeller (DIR Est), Thomas Gotthardt (MAIBACH), Cathy Guillot (ECOSCOP), Christine Henn (Mobil Hessen), Tompy Hoedelmans (OMGEVING), Sylvia Idelberger (Stiftung Natur und Umwelt RLP), Eric Jourdan (Besançon Education Department), Fiona Macri (Rhin Vignoble Grand Ballon (RVGB)), Frédéric Marques (ULMA Architectural Solutions), Philippe Maillard (Pro Natura), Daniel Martin, Gaëtan Masson (ATMB), Pierre Mazuer (Cerema), Annette Mertens (Lifestrade.it), Mathieu Narce (Institut méditerranéen du patrimoine cynégétique et faunistique), Catherine Néel (Cerema), Éric Nicolas (DIR Est), Gérald Pagneux (Cerema), Julie Palaysi (VOLVO Cars), Olivier Pichard (Cerema), Vanessa Ruel (Cerema), Emmanuel Rondeau, Carme Rossel (Minuartia), Laure Rousselle (CD 24), Jean-Marc Ruez (Commune d'Ahuy), Marion Semmer (VINCI Constructions), Romain Sordello (OFB), Julien Soret (Métropole du Grand Nancy), Marek Stolarski (NEEL Pologne), Olivier Subregis (TecInfra), Stefan Suter (WildLife Solutions), Marc Thauront (Ecosphère), Pierre-Antoine Thévenin (Union nationale des entreprises du paysage), Catherine Thibaudat (ACO), Perrine Vermeersh (Cerema), François Varenne (Ligue pour la protection des oiseaux 85), Irvin Van Hemert (Luchtfotografie), Frédéric Voegel (DREAL Grand Est), Martin Weber (PIRSCH), Jean-Paul Zimmer (DIR Est).

How to cite this publication:

Cerema. *Fauna passages. Maintaining and restoring the ecological network, with linear transport infrastructure*. Bron: Cerema, (2023). Series: references.

ISBN: 978-2-37180-610-8 (pdf)

Foreword

This guide is a methodological and technical work designed to provide a maximum of recommendations necessary to take into account the ecological network when designing or upgrading infrastructure.

In order to facilitate its use without necessarily having to read the entire document, this guide is built around four main parts, each corresponding to a specific topic. Each section is itself divided into a series of fact sheets designed to answer the questions raised by the stakeholders involved in a road or rail development project.

Foreword for publications translated into foreign languages

The purpose of translated documents and publications is to pass on to non-French speaking readers the French know-how set out in the original publication, whether this concerns methodologies, tools or best practices. Original publications in French are subject to a checking process, which leads to a Cerema commitment regarding their content. English versions do not undergo the same process, and consequently carry no Cerema commitment. In the event of differences between the English and the original French text, the French text serves as the reference.

Contents

■ Preamble 11

P A R T I

■ The ecological network and land transport infrastructure 14

FACT SHEET 1.	What is an ecological network?	16
FACT SHEET 2.	What methods can be used to identify the ecological network?	22
FACT SHEET 3.	Why should the ecological network be taken into account as part of a linear transport infrastructure project?	28
FACT SHEET 4.	How to provide an effective response to the disruption of the ecological network?	42

P A R T II

■ Fauna passages: an effective measurement to re-establish transversal connectivities 58

1.	Fauna passages on new infrastructure projects	62
1.1.	All fauna passages	64
FACT SHEET 5.	Where to build an all fauna passage*?	66
FACT SHEET 6.	What type of all fauna passage should be chosen?	77
FACT SHEET 7.	How to size the passage?	90
FACT SHEET 8.	How to design and develop all fauna passages?	106
FACT SHEET 9.	What are the different types of construction? At what cost?	133
1.2.	Passages and developments for small fauna	136
FACT SHEET 10.	Where to build small fauna passages?	137
FACT SHEET 11.	How to develop small waterway structures for small fauna?	140
FACT SHEET 12.	How to develop agricultural/forest/pedestrian structures for small fauna?	154
FACT SHEET 13.	How to develop specialised passages (amphibian passage - tree canopy passage)?	156
FACT SHEET 14.	How to develop common small fauna passages?	165
2.	On existing infrastructure - Upgrading	178
2.1.	Development and/or upgrading of existing structures	179
FACT SHEET 15.	How to improve the functionality of existing fauna passages?	180
FACT SHEET 16.	How to promote the passage of small fauna on existing structures not dedicated to fauna?	183

	2.2. Construction of new structures on existing infrastructure	196
FACT SHEET 17.	Where and how to build an all fauna passage on existing infrastructure?	197
FACT SHEET 18.	How to create a small fauna passage on existing infrastructure?	199

	2.3. Autres aménagements	205
FACT SHEET 19.	What are the warning systems (fauna and/or vehicles) set up to reduce wildlife vehicle collisions?	206

P A R T III

- **Green rights-of-way: supporting longitudinal continuities** **212**

FACT SHEET 20.	How to integrate biodiversity into the design of rights-of-way?	217
FACT SHEET 21.	How to ensure fauna's access to rights-of-way while ensuring its protection? Fences and barriers	227

P A R T IV

- **How to ensure the long-term efficacy of measures: maintenance, monitoring** **254**

FACT SHEET 22.	How to maintain fauna passages?	256
FACT SHEET 23.	How should fauna passages be monitored?	260









- **Glossary** **267**

- **List of abbreviations** **275**

- **Bibliography** **279**

- **Table of contents** **293**

Boxed items in the guide are coded:

-  Information from feedback, scientific publications, etc.
-  Indication of the possible costs of the measures. Prices are indicative and are based on feedback (sometimes a single reference) whose specific features (economic situation, size of the market, technical characteristics, etc.) inevitably induce strong variability. Values also vary due to market developments and should therefore be updated according to the date of use.
-  "The essentials" summarise the most important points of the relevant chapter.
-  Point of vigilance.
-  The solution is possible but must be avoided.  The solution is prohibited.  Recommended solution.
-  Referral to the glossary.

Preamble

Mainland France is located at the crossroads between four of the six biogeographical zones of Europe: Atlantic, Continental, Mediterranean and Mountainous. The variety of climates, soil types and altitudes creates a very broad diversity. The mainland territory includes around 6,000 species of higher plants* and almost 1,500 vertebrate species, of which half in the marine environment. However it is difficult to say how many animal species exist in total as knowledge remains fragmentary for certain groups of invertebrates. For insects alone, nearly 40,000 species are currently recorded. France is affected by biodiversity hotspots* in the Mediterranean, the West Indies, Polynesia, New Caledonia and the Indian Ocean.

Biodiversity is part of the common heritage that deserves to be preserved as such. It also provides a large range of services to human societies: ecosystem services. It provides oxygen, food, raw materials and even molecules from which certain drugs are made. It is also used to provide certain services such as pollination

(70% of crops depend on animal pollination, by insects in particular), soil fertilisation, water purification, flood prevention, landscape structuring or improving our living environment.

According to the 2018 IUCN Red List of Endangered Species in France, of the 2,712 species assessed for fauna and flora, 93 are critically endangered, 180 are endangered and 626 are classified as vulnerable. The erosion of biodiversity is speeding up. The scientific community estimates that the current rate of species extinction is 100 to 1,000 times higher than the natural rate of extinction (IPBES, 2019). In the European context, France is the 5th country, after Spain, Portugal, Italy and Greece, which is home to the largest number of globally endangered species. This accelerated erosion is almost exclusively connected to human activities. The five major causes of biodiversity loss are now identified: loss and fragmentation of ecosystems, overexploitation of wildlife, introduction of invasive alien species, pollution and climate change.



Red fox. Source: François Nowicki.

Among these causes, the disappearance and fragmentation of ecosystems in France are partly linked to the development, since the 1960s, of land transport infrastructure, especially when its permeability has not been ensured. Today, although there are far fewer new infrastructure projects and the natural environment is increasingly taken into account, the impact of these new discontinuities in the natural environment is often reinforced by the existing level of fragmentation.

Land-use planning today therefore involves maintaining the existing ecological network when designing new projects, but also restoring, on existing infrastructures, the terrestrial, aquatic and semi-aquatic ecological functionalities that had been previously interrupted. The purpose of this technical guide is to help and make it easier to factor in these issues when working on the various linear transport infrastructure development projects. In particular it updates the former reference guides entitled *Passages for large fauna*, SETRA, 1993 and *Facilities and measures for small fauna*, SETRA, 2005.

It consists of four parts, each containing a series of fact sheets designed to answer any questions that infrastructure operators may have. Part one aims firstly to provide the information necessary for clear understanding of the issues involved in the ecological network and the reasons why it is necessary to take it into account in the context of an infrastructure project. Parts two and three cover more technical areas and explain in detail, depending on the configurations, how it is possible to restore or maintain the ecological network whether it is transversal (fauna passages) or longitudinal (development of green rights-of-way). Finally, part four gives indications on the possibilities of ensuring the effectiveness of the aforementioned measures over time, through the maintenance and monitoring of those measures.



THE ECOLOGICAL NETWORK AND LAND TRANSPORT INFRASTRUCTURE

FACT SHEETS

- 1 What is an ecological network?
- 2 What methods can be used to identify the ecological network?
- 3 Why should the ecological network be taken into account as part of a linear transport infrastructure project?
- 4 How to provide an effective response to the disruption of the ecological network?

What is an ecological network?

A land-use planning tool

The blue and green grid* (TVB) was introduced in French Law by the so-called "Grenelle I and II" Acts of 2009 et 2010. It is a sustainable land use tool whose primary objective is to halt the loss of biodiversity*, by conserving and improving the ecological quality of the environment and guaranteeing the free movement of species of wild fauna and flora.

It also aims to:

- support climate evolutions by enabling a majority of species and habitats to adapt to climate change;
- ensure the provision of ecological services;
- promote sustainable activities, including agriculture and forestry;
- control urbanisation, the location of infrastructure and improve the permeability of existing infrastructure.

The green and blue grid is based on an ecological network that allows the movement of terrestrial and aquatic living beings. This network helps ensure their life cycle*.

The ecological network comprises two types of elements: "biodiversity reservoirs" and "ecological corridors" (Articles L.371-1 and R.371-19 of the French Environmental Code*).

- **Biodiversity reservoirs** (❶ page opposite) are areas in which biodiversity, rare or common, endangered or not, is the richest or best represented, where species can complete all or part of their life cycle (feeding, breeding, resting) and where natural habitats can continue to function, in particular by reaching a sufficient size. These are areas that can accommodate cores populations of species from which individuals disperse, or areas that are likely to welcome new species populations.

- **Ecological corridors** (❷ page opposite) make connections between biodiversity reservoirs, offering species favourable conditions for their movements and the completion of their life cycle. Ecological corridors can be linear (hedge, linear surface, etc.), discontinuous (Japanese step structures, stopping points, refuge islands, etc.) or landscaped (matrix of various structures).

The green and blue grid can be broken down into sub-grids* corresponding to ecological networks identified for the different types of environment (❷ page opposite). The French Environmental Code* defines the various sub-grids to which biodiversity reservoirs and ecological corridors may be attached: wooded areas, open areas, wetlands, watercourses and, where applicable, coastal environments (art. R371-27 of the French Environmental Code). All these sub-grids are compiled to form the green and blue grid (TVB).

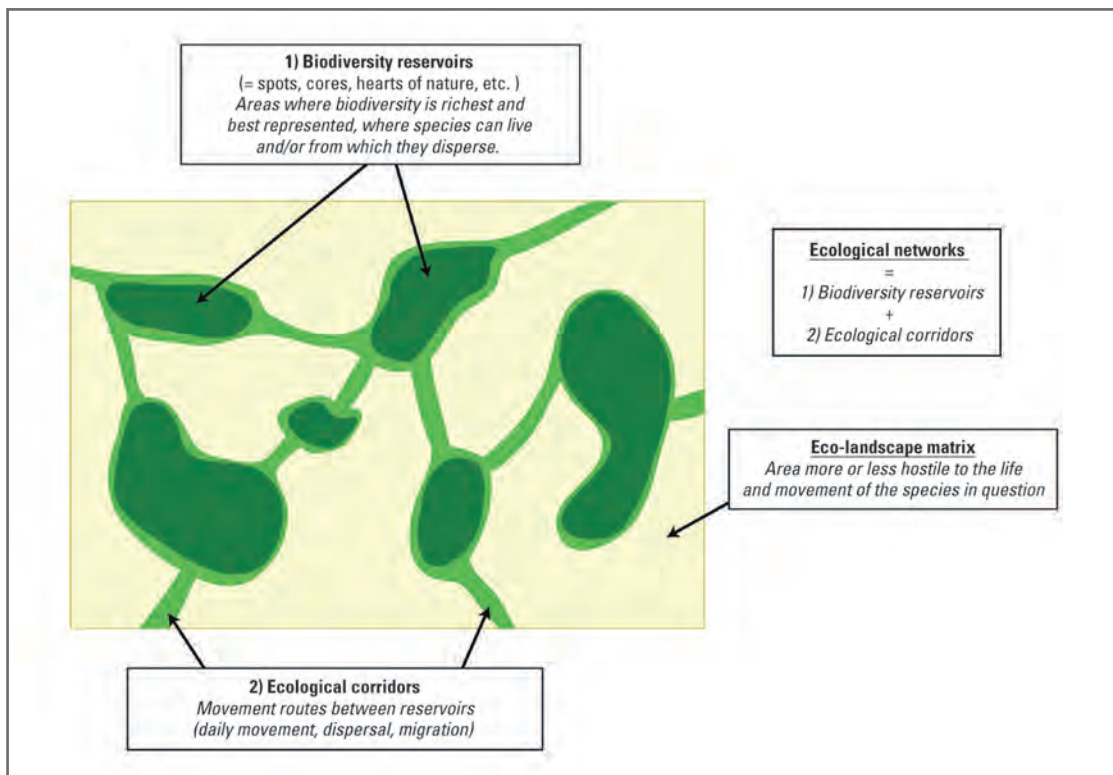

1 Theoretical diagram explaining corridors, biodiversity reservoirs and ecological networks.
Source: UMS PatriNat, <https://inpn.mnhn.fr/programme/trame-verte-et-bleue/presentation>

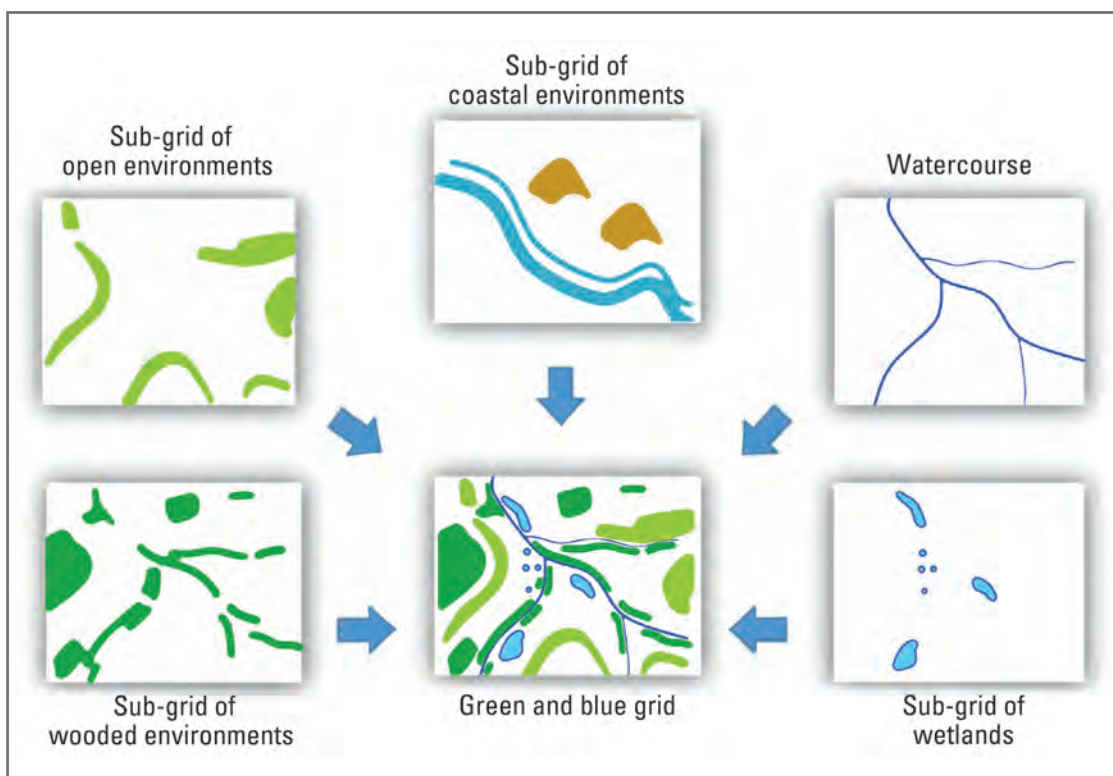

2 The five national sub-grids*. Source: UMS PatriNat.

To implement this policy, the French State relies on a framework document, the *Orientations nationales pour la préservation et la remise en bon état des continuités écologiques* (ONTVB), adopted by the decree dated 20 January 2014 and revised by the decree dated 19 December 2019, whose primary objective is to allow the implementation of a coherent green and blue grid (TVB) throughout the territory, by an approach involving different levels of action:

- at the national level. The ONTVBs identify national and cross-border issues and specify the framework chosen to identify continuities with the regional level;
- at the regional level (according to the old administrative breakdown). The TVB has been adapted to a more precise scale through regional ecological coherence schemes (SRCEs). The SRCE is a framework document developed in each region. It includes, among other things, a presentation of regional ecological network issues, a mapping of regional ecological networks (the regional green and blue grid* on a scale of 1/100,000) and the strategic action plan for their preservation or restoration. However, the regulatory context concerning the implementation of the green and blue grid has evolved following the Act dated 7 August 2015 on the new territorial organisation of the French Republic (known as the "NOTRe Act").

It provides each Region with a prescriptive planning document: the *schéma régional d'aménagement, de développement durable et d'égalité des territoires* (SRADDET) into which the SRCE must be integrated. SRADDETs are intended to replace the SRCEs, which will become obsolete once the SRADDETs are adopted (except for the Greater Paris region);

- at a more local level, planning documents (SCoT, PLU(i) and municipal maps, etc.) and projects of the State, local authorities and their groups, in particular regarding **infrastructure**, must then take into account their region's SRCE and embed the objective of maintaining and restoring ecological networks into their own territory or at the project level.

The ONTVBs are binding on planning documents and projects at the national level, in particular on the major linear transport infrastructures of the State and its public establishments, to ensure compatibility (Article L. 371-2 of the French Environmental Code*). The issues of national coherence of ONTVBs (lists of species/habitats, protected areas and ecological networks of national importance) are to be integrated into the application of the "avoid, reduce, offset"* sequence of the environmental assessment of documents and into the impact assessment of projects at the national level.

An ecological reality essential to the conservation of species

The ecological network can be defined according to several scales of perception whose contours are globally determined according to its role in maintaining species in a territory (possibility of completing their biological cycle) and in maintaining exchanges between populations of species (dispersion).

In each case, to allow ecological networks to play their part, they must be functional, that is to say, allow **the safe movement of species**,

through a sufficient number of favourable habitats and appropriate organisation of such habitats. Unfortunately, in many cases, during their movements, species pass through infrastructure that can become mortality sinks for the population. It should also be noted that an environment that is part of a continuity can be an obstacle* for species of other environments (e.g.: a forest corridor can be an obstacle* for certain orthoptera species* living in open environments).

The ecological network supports exchanges needed to complete species' life cycle

For a species to remain on a defined territory, it needs vital spaces which provide it with the resources to feed, reproduce and find shelter. The species must be able to move between these spaces to meet its needs. While these movements can be categorised, they are however very variable depending on the species, the season and the environments.

The ecological network to support movements in search of food

The search for food and water is one of the main reasons for species movement. Needs vary from one species to another. Choices of habitat are very different and the distances between diverse resources vary a lot depending on the species and on food availability.

It is estimated that, on average, carnivores have to travel four times more than other species. Generally, however, travel distances related to the search for food and water remain quite limited.



Wildcat

Depending on food availability (voles) in its environments, a wildcat is likely to join and exploit different environments (forest, meadow, etc.) in a more or less sustained way, over different lengths of time (seasons, years).



Wildcat Source: François Nowicki.



European otter

The home range of adult males can reach 20 to 50km along a river. That of females hardly exceeds 5 to 20km, depending on the size of the rivers and their feeding potential. It seems that the narrower the river, the longer the home range, because the otter needs to travel a longer distance, in order to cover a sufficient surface area to satisfy its trophic needs*.

Wild boar

Between its refuge areas (enclosed wooded environment) and its feeding areas (crops, meadows, etc.), the wild boar can travel more than 10km.

The ecological network to support movements in search of sexual partners and places of reproduction

Reproduction is a basic need shared by all living species. Every species must have an efficient reproductive system, otherwise it would be threatened with extinction. Reproduction can be coupled with spatial movements for partners to meet and join a suitable breeding habitat.



Deer

Stags can travel up to 15km to reach does in rutting areas*.

The rest of the time, both sexes use the environment differently and occupy territories of different sizes.



Red Deer Source: François Nowicki.



Common toad

During the migration period*, the common toad can travel up to 3km between its living environment (forest) and its breeding site (lake, pond, etc.).



Common toad Source: François Nowicki.

The ecological network to support movements in search of shelter

During the day or depending on the season, species need to find places of shelter where

they can rest and hide from predators. While some species find the same shelter every day (e.g. badgers), for many others, their place of residence is above all a living area where they shelter rather than an identical and permanent location to which they return after their activities. The roe deer, for example, is most often nomadic in its territory and regularly seeks a new place to shelter from the weather or from predators. A territory may therefore include several well-identified refuge zones that the species is likely to use as it moves.

Some species use a fixed shelter for varying lengths of time: part of the day, all year round or part of the year for example. Many species therefore occupy a very specific place to give birth and raise their offspring, as do hibernating species. Sometimes, they travel very long distances to reach these different places. This is particularly the case for migratory species, such as certain bats.



Badger

Essentially a nocturnal species, the badger lives during the day in a sett that it leaves every day at dusk to feed, returning to it before daybreak (daily movement of about 2km). The burrow will most often have been dug and maintained by the badger near water and feeding areas.



Clan of badgers. Source: François Nowicki.

The ecological network supports the necessary exchanges between populations (dispersion)

The ecological network also supports exchanges between different populations of the same species. These exchanges are necessary to ensure the good conservation status of species, maintaining genetic diversity, and to reduce the risks associated with inbreeding, for example.

Exchanges between different populations or metapopulations* can take place through the dispersal mechanism. This term generally refers to all processes whereby living beings geographically separate themselves from an original population and colonise (or recolonise) a territory. It is thus strongly correlated with reproduction. Dispersal may occur after birth and before the very first reproduction or between two reproductive events.

Dispersal is divided into three stages: firstly emigration, when the individual leaves its original

habitat, then transfer and finally, immigration, settlement in the new habitat. It allows species to colonise or recolonise environments that are conducive to their development, but it has a cost in terms of time, energy, risks, etc. The dispersal capacities of species are essential for genetic diversity, population survival, adaptation and ecological resilience*.



► Experts estimate that the maximum dispersal distance of the **osmoderm beetle (hermit beetle*)** is a few hundred metres (OGE, 2007).

► Unlike the lynx, which colonises neighbouring spaces, in contact with territories already occupied, **the wolf** tends to colonise new distant territories that can be several tens of to several hundred kilometres away. While dispersions often fall within a radius of 150km, the longest distances recorded have been 1,000km to 1,500km away. (Vignon, 2017).

FACT SHEET

2

What methods can be used to identify the ecological network?

For a given territory, maintaining an ecological network conducive to the movement of the greatest number of species of wild fauna and flora requires different scales of analysis. This analysis is important because not all species have the same movement capacities. For some that travel long distances, for example, the regional scale may make sense, but for species whose movements are more localised, such as amphibians or insects, a much smaller scale is required.

Each level of scale (national, regional, local) must make it possible to provide a response adapted to the challenges and the size of the territory studied by helping to specify the issues of higher levels.

Maps of ecological networks are available at the national or even regional level. But documents describing quite large territories (e.g. SRCE or SRADDET, national interest networks) do not show all the ecological network elements that fall within the scope of lower planning levels (SCoT, PLUi, PLU, etc.) and for which a smaller cartographic scale is necessary within the framework of a local project (1). Simply zooming in does not provide enough precision to define the ecological network at the local level.

During the implementation of an infrastructure project, the identification of corridors and biodiversity reservoirs* will have to be based on available documents and investigations, depending on the level of precision expected during the different phases of the project.

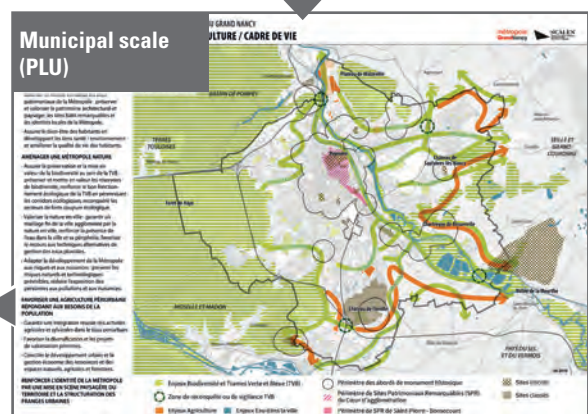
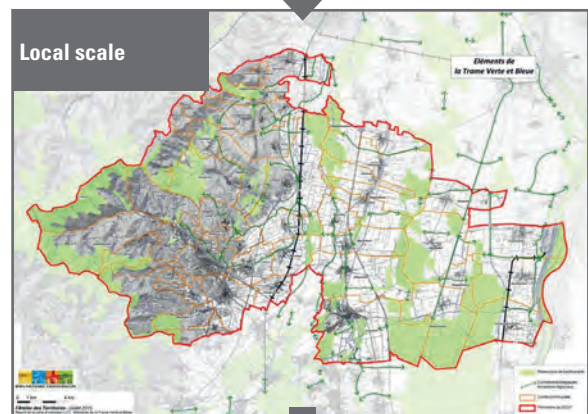
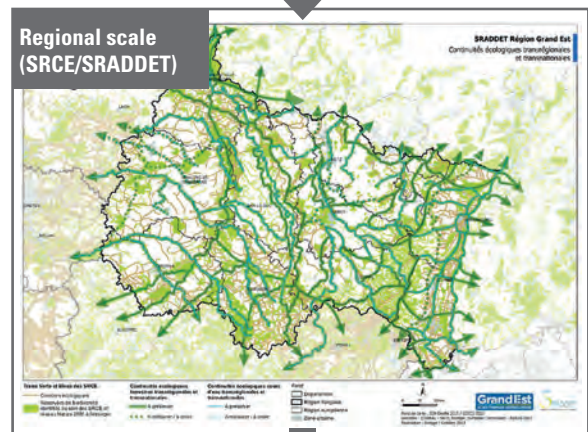
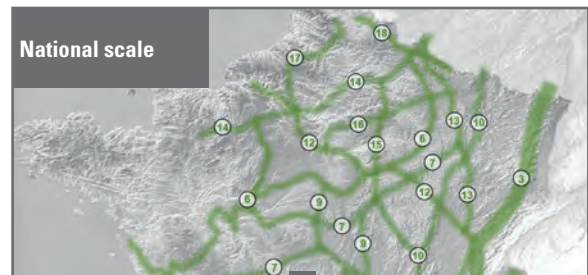

1 Cartographic representations of ecological networks at different scales.

Source: UMS Patrinat, Région Alsace/DREAL* Alsace, Atelier des Territoires, SCALEN - PLUi du Grand Nancy. (Important: these maps have no geographical link.)

IDENTIFICATION OF COMPONENTS OF ECOLOGICAL NETWORKS

Identification of biodiversity reservoirs*

There are several and often complementary methods for identifying biodiversity reservoirs. To summarise, three approaches can be used at different scales of work, independently or cumulatively, depending on the accuracy of the data already known or identified.

Integration of existing alert perimeters

The first step is to necessarily integrate areas benefiting from regulatory protection (e.g. nature reserve*, biotope protection order, etc.). It is also recommended to add watercourses and wetlands of special environmental interest. Finally, depending on the value that their contribution may bring, certain perimeters (ZNIEFF, Natura 2000 site*, ENS, etc.) that reflect a specific biological wealth, will be associated.

The species or multi-species centred approach

This involves adding to the previous analysis the data (outside the alert perimeter) on the location of heritage species - or not (ordinary biodiversity) - which is sensitive to fragmentation. These are derived from the bibliography or field studies, undertaken in particular in the context of files compiled prior to infrastructure projects. It is thus possible to define possible complementary biodiversity reservoirs linked to the presence of these species.

The contour of these reservoirs must correspond to a coherent ecological unit where the presence of the different living habitats of these species (refuge area, feeding area, etc.) is an essential condition for their presence. To identify these reservoirs, land-use analysis is therefore a complementary approach to data on the presence of one or more species, which makes it possible to check the presence of the environments sought by such species.

In the context of an infrastructure project, this species-based approach is often only possible in very specific cases, on a small scale, linked to the presence of one or a few high-issue heritage species requiring special attention.

In a more general context, the multiplication of the number of species likely to coexist in a landscape crossed by an infrastructure can make a species approach very complex. In this case, it is possible to conduct a more inclusive approach, namely:

- through a species-based approach while focusing on living habitats of one or a few "umbrella" or "keystone" species.

An umbrella species is a species whose scope of habitat and territorial needs is such that its preservation also makes it possible to preserve a series of other species coexisting in the same ecosystem, but with fewer requirements, especially in terms of space. Therefore the protection of habitats allowing the maintenance of demanding target species will, in principle, also safeguard less demanding species.



E.g. the violet click beetle (*Limonicus violaceus*) is a discreet saproxylic* species, associated with the low cavities of deciduous trees. Its presence is accompanied by remarkable biodiversity, characteristic of old European forests (diversity of species, remarkable species).

A so-called "keystone" species is a species whose disappearance would compromise the structure and functioning of a whole ecosystem. It is characterised by the quality, number and importance of its connections with its habitat and with other species. In this sense, a keystone species is necessary for the existence and maintenance of other species.



E.g.: woodpeckers, including the black woodpecker, are species that play a major role in creating and leaving cavities for other cave-dwelling species that are incapable of digging their own cavity (owls, bats*, etc.). Their regression can thus lead, in the long term, to the disappearance of other species using the cavities created by woodpeckers.



Black woodpecker. Source: François Nowicki.

- by taking an approach that focuses on the living environment of a species with the same ecological requirements, indicators of each environment, indicators of each environment or sub-grid* (indicator species of forest environments, open environments, etc.). Once these species have been defined for each sub-grid, the objective is to draw up a map of the environments conducive to these species (e.g. ungulates, indicator species of the forest sub-grid) on the basis of land-use.

The landscape approach

While certain perimeters or territories of heritage species are generally considered as biodiversity reservoirs*, it is also possible to integrate natural areas that can play a role because of their high potential, their wealth in terms of ordinary and/or heritage species, the absence of fragmenting elements, their degree of naturalness, their surface area, their homogeneity (functional whole without discontinuity), their compactness or permeability. This is often the case, for example, with vast forest areas. The aim here is to take a slightly more comprehensive approach to analysing the territory, less focused on the habitats of a species or a series of specific species.

..... Identification of ecological corridors

On the basis of biodiversity reservoirs, the aim is to conduct spatial analyses to identify physical continuities between these reservoirs which are liable to be used by species during their movements, in particular for their dispersal.

Ecological corridors are identified according to many factors including the scale of work, the size of the study area, the available data, etc. The definition of ecological network therefore usually uses different approaches that can be combined. These methods often require prior identification of potential continuities then an analysis of

fragmentation elements and, lastly, a **validation based on assessment by a naturalist or a field phase.**

The land or environment use approach

This is the most frequently used method to characterise the green and blue grid (TVB) at the regional level. It is proposed in the framework of the national guidelines for the preservation and restoration of the ecological network.

This approach is based on three possible spatial analysis methods:

■ **Visual interpretation**

Based on aerial photographs or land-use maps, visual analysis makes it possible to identify the corridors potentially used by species from biodiversity reservoirs (differentiating, if necessary, each sub-grid or type of environment). The routes are chosen according to the most direct path between biodiversity reservoirs*, integrating the most favourable environments for movement, stopping point environments, obstacles,* etc.

This method is particularly effective when the study area is well known and the surface to be treated remains small.

■ **The analysis of distances between biodiversity reservoirs**

Using the distance liable to be travelled by the species (target, umbrella, indicator or group of species) outside its refuge habitat, this method, under GIS, materialises the space likely to be used by the species for its dispersal in the form of buffer zones around each reservoir, regardless of the quality of the external habitats. This operation reveals connecting areas between spots that can be considered as potential corridors (see example of the expansion-erosion method ②). However, this method does not take into account the nature of the environments or the obstacles* present. Some connections may be longer but more efficient, when the nature of the environment is more permeable.

■ **Analysis of the permeability of environments to the movement of target species groups and continuum calculation for each type of environment (sub-grid*)**

This analysis is based on a GIS method that models the movement of indicator species from a type of environment within the different categories of land-use. This would be, for example, the movement of a species representative of the forest environment within grasslands, crops, etc.

The modelling is based on a movement cost calculation algorithm that takes into account the permeability of each environment for the target species and can incorporate potential obstacles*. Each land-use category is assigned a resistance value proportional to the effort that the animal is willing to make to colonise or move in an environment other than its living space (it is generally established that the species has no difficulty moving in its reference environment).

This method ultimately makes it possible to model the sub-grids (forest, meadows, etc.) corresponding to the potential area of movement of the targeted species representative of these sub-grids.

The different synthetic maps of each sub-grid are compiled in order to highlight the major functional areas of the territory.

Different types of software use this analysis method. Mention may be made of: Graphab, Circuit scape, Metaconnect, Least-cost path analysis.

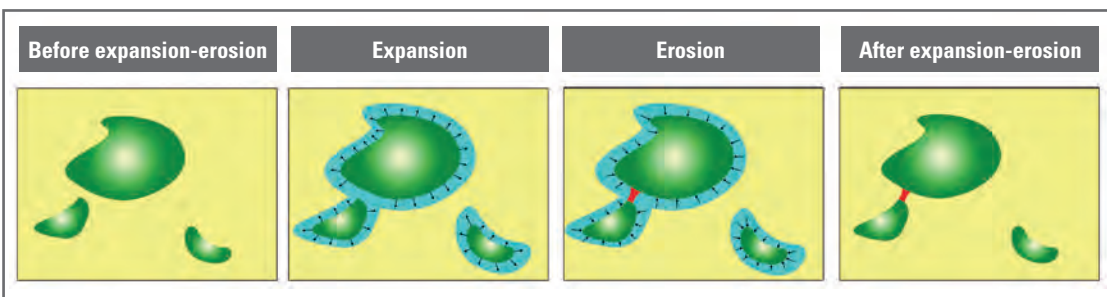

② Principle of the expansion-erosion method Source: UMR-Tetis – Inrae.



Study of the impact of the East LGV (high-speed train line) on the operation of ecological networks – Analysis of the territory of 12 municipalities

The ecological network was defined using “cost-displacement” modelling software to define each sub-grid* on the basis of the virtual displacement of indicator species in each type of environment. For each sub-grid, the propagation zone obtained (structuring environment, attractive environment) by modelling was considered as the theoretical continuum of the habitat of the ecological group studied.

The compilation of forest, wetland and prairie continuums has thus made it possible to define the ecological network of the territory crossed by the infrastructure.

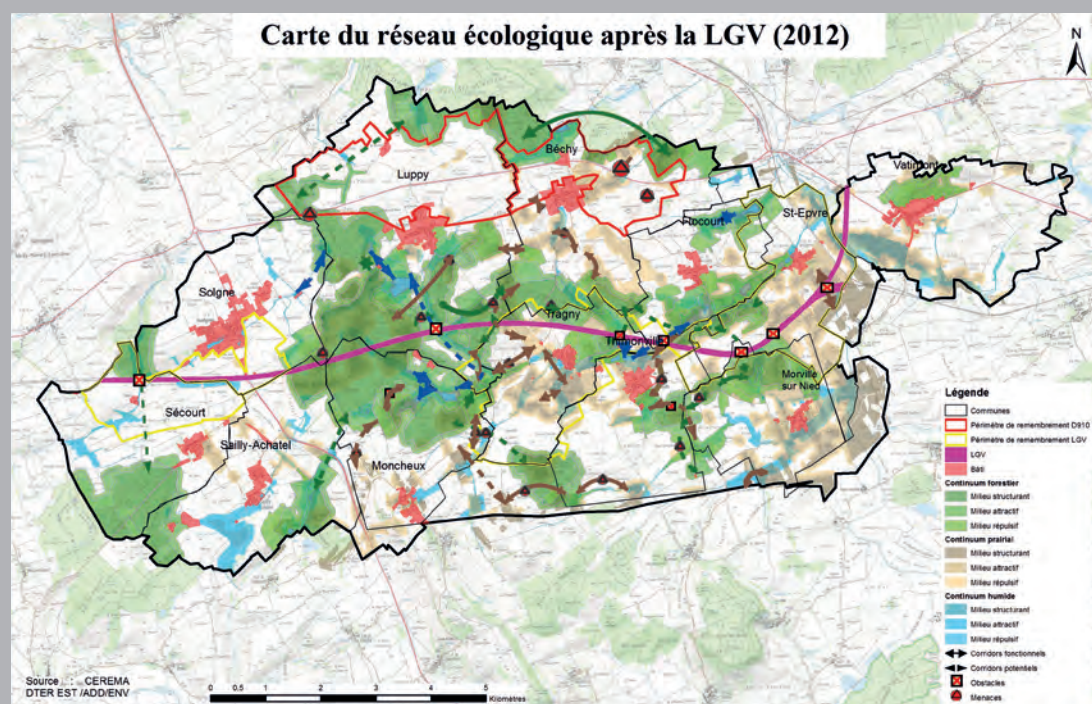

Special case of the black grid*

Artificial light is likely to create a barrier effect because of the repellent effect it constitutes for light-fugitive species*. Conversely, it is also likely to constitute an ecological trap by attracting other species at the risk of being hit (this is the case, for example, of certain bats who come to hunt insects near street lamps, which are themselves attracted by light). This is a cost-benefit behaviour: the opportunity to feed while incurring the risk of being a victim of predation.

When on the move, most bats* avoid lit areas.

When the TVB policy was introduced, the problem of light pollution was not considered to be a political priority on the one hand, and on the other hand, it was not developed in an operational way. Nevertheless, there are an increasing number of initiatives and the adapted ONTVB framework document (2014) indicates the need to take into account emerging issues, such as light pollution, more effectively.

There are several ways to integrate this issue into a TVB. One possibility is to identify areas of conflict between the TVB and light pollution (Granier, 2012). Another possibility is to go so far as to identify a black grid*, i.e. ecological networks characterised by their darkness, to be preserved or restored. This network can be obtained from an already characterised green and blue grid*, from which areas that are too bright are removed. But it can

also be identified by directly taking into account the darkness needs of nocturnal species, when identifying corridors and reservoirs. In France, approaches to identifying black grids have begun to emerge in recent years (e.g. AUBE (*Aménagement, urbanisme, biodiversité, éclairage*) fact sheets, Cerema 2020; *Trame noire - Méthodes d'élaboration et outils pour sa mise en œuvre*, OFB 2021).



Identification of the black grid of Nantes Métropole

This map represents the theoretical black grid calculated using a light pollution potential according to the classification of zenith luminance (light reflected back to the sky from the treatment of nocturnal orthophotography*). The following are included :

- the selection of areas for future urbanisation which are on the theoretical black grid and whose land-use may be favourable to species;
- adjustable (or not all or slightly adjustable) ecological corridors of the TVB's Planning and Programming Guideline (OAP);
- potential ecological works of TVB's OAP.

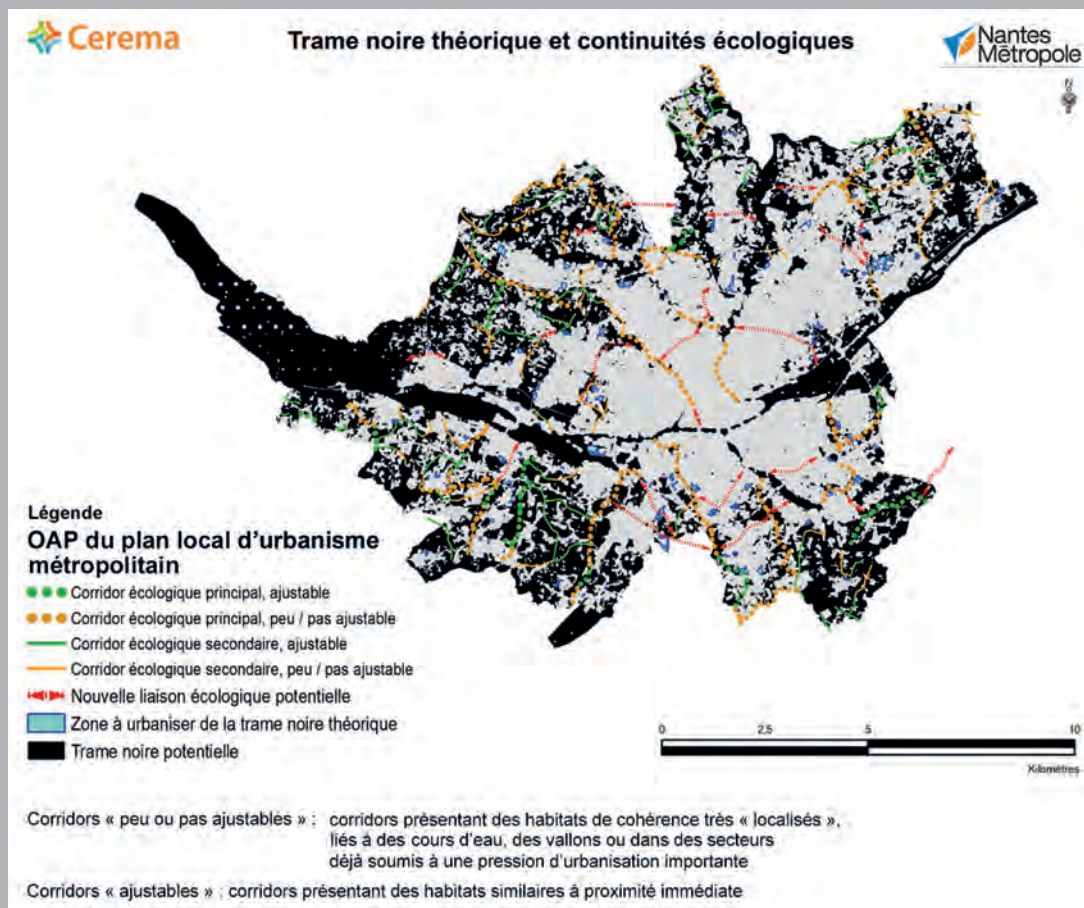

Source: Cerema.

Why should the ecological network be taken into account as part of a linear transport infrastructure project?

A regulatory requirement

On planned infrastructure

- Pursuant to Article L371-2 and 3 of the French Environmental Code*, "planning documents and projects at the national level, and in particular the major linear infrastructure of the State and its public institutions, must be compatible with national guidelines for the preservation and restoration of ecological network (ONTVB) and specify the measures to avoid, reduce and, where appropriate, offset* the damage to the ecological network that the implementation of such planning documents and projects, in particular major linear infrastructure, may cause environmental concerns that the implementation of these planning documents and projects, in particular large linear infrastructures, are likely to raise ".

- Infrastructure projects subject to impact assessment, pursuant to Article L.122-1 and R.122-5-4° of the French Environmental Code must appropriately describe and assess, according to each specific case, the significant direct and indirect impacts of a project on biodiversity*, paying particular attention to species and habitats protected under Directive 92/43/EEC dated 21 May 1992 and Directive 2009/147/EC dated 30 November 2009.

- Public infrastructure projects (of the State, local authorities and their groups), whether subject to impact studies or not, pursuant to Article L.371-3 of the French Environmental Code, must take into account the SRCE or be compatible with the SRADDET, if one exists, and specify the measures to avoid, reduce and offset damage to the ecological network.

Environmental studies relating to a project must lead to an understanding of the effects on

biodiversity and the ecological network from the outset of project design and in all appraisal procedures, through to the decision to carry out the project or not.

On the basis of an inventory of ecological networks, the studies should make it possible to take into account all the direct, indirect, induced and cumulative effects of the construction of the infrastructure. This analysis should then make it possible to define the measures needed to avoid harmful consequences. Biodiversity reservoirs and ecological corridors must therefore be preserved as much as possible by avoiding choices of geographical or technical opportunity. If this is not possible, reduction measures must be defined to ensure the preservation of functionality spaces. If, despite avoidance and reduction measures, biodiversity reservoirs and corridors are not adequately preserved, offsetting measures will have to be implemented.

They must comply with the principles of environmental offsetting, defined in Article L.163-1 of the French Environmental Code, and be accompanied by follow-up measures in accordance with Article R.122-5-9° of the same Code.

The set of measures designed to avoid, reduce and offset, known as the "ARO sequence"*, targets the absence of net loss of, or even a gain in biodiversity*. These measurements must allow the non-deterioration of the overall permeability of each sub-grid* studied at the project scale.

Lastly, in the context of a new project, the ecological network is also very often analysed through the protected species derogation procedure provided for in Article L.411-2 of the French Environmental Code*.

On existing transport infrastructure

While there is no general regulatory obligation to restore the ecological network disrupted by the passage of old infrastructure, some works to improve the existing network, depending on their importance (e.g. addition of a motorway lane), may require upgrading and new defragmentation measures as for new projects (see also fact sheet 4).

The consideration of the green and blue grid* must then be supported by an assessment of the level of breakdown of ecological networks, and be based, among other things, on the

distribution of ecological networks and on the specific characteristics of each infrastructure or structure.

In the absence of an obligation to improve ecological transparency linked to specific works, for existing linear infrastructures, the challenge is to be able to prioritise and optimise a programme of works aimed at restoring the permeability of network infrastructures and structures, particularly in areas where the stakes are the highest, whether through dedicated projects (subject to obtaining funding in this regard) or for other projects, but giving the opportunity to improve long-standing deteriorated or broken ecological networks.

An ecological necessity

Transport infrastructure affects environments and their biological components through a range of processes that are connected in space and time. The interruption of an ecological network by a road or railway line is certainly one of the main disturbances, which results both in the fragmentation of spaces and in the creation of a risk of collisions for all species wishing to continue to cross the infrastructure.

reinforced by the presence of any fences and finally by traffic disturbances, noise, lighting, vibrations, etc.

The main effect of this barrier is to interrupt ecological networks and all the ecological processes inherent in such networks.

Fragmentation

Fragmentation is a dynamic process of habitat area reduction and separation into several fragments. For transport infrastructure, it is induced by the cut-off effect created by the destruction of habitats next to the road coverage (clearing, earthworks), by the presence of the physical barrier created by the infrastructure itself (roadway, railway platform, electrical or signalling installation, earthworks) whose effect is

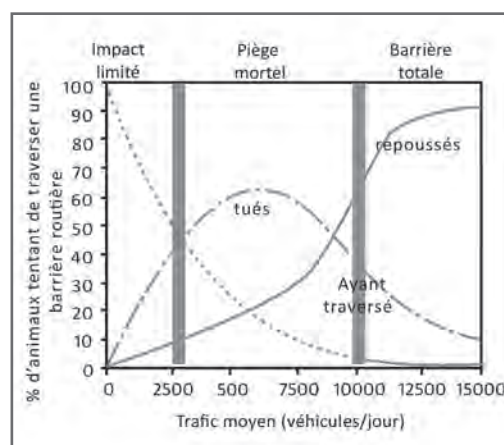

Fragmentation effect of road infrastructure according to average daily traffic.

Source: COST 341 report adapted from Seiler, 2003.



Effect of a three-lane road on the movement and abundance of a species of ground beetles*

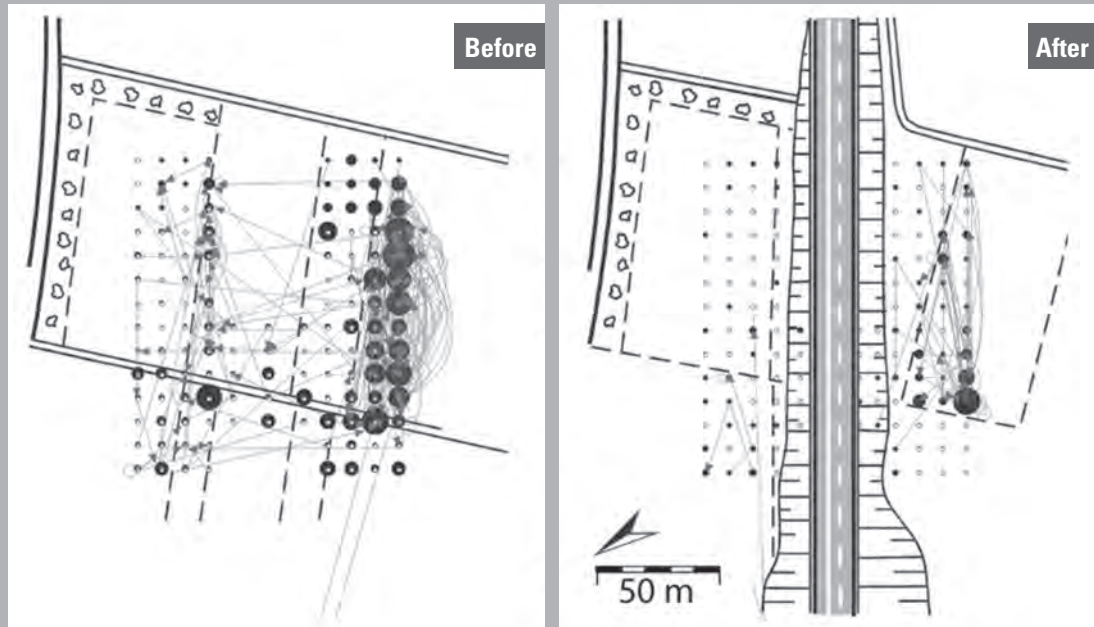

Source: *Hand book of road Ecology*, adapted from Pfister et al. (1997).

Prior to construction, numerous traps were used to capture more than 20 males, which crossed the site of the future infrastructure several times.

After construction, the capture rate and movements were significantly lower.

However, the scale of the barrier effect remains highly variable and depends on several factors:

- **the characteristics of the infrastructure:** the wider the infrastructure, the greater the cut-off effect. The longitudinal profile (excavation/embankment) also plays a role, in particular with regard to flying fauna;
- **the surface:** the simple presence of a structure coated with asphalt or railway ballast can create a physical barrier for some species;
- **the presence of equipment:** adherent concrete barriers, fences, U-shaped concrete gutters, covered ditches, rails, etc.

For fences, the cut-off effect will depend in particular on its technical quality (resistance to burrowing*, maintenance to ensure its continuity and accessibility), its height, the size of the mesh (large-meshed fencing will have little effect on species of small fauna) and the quality of the

connections to adjacent features (openings, grids, lower or upper structures, etc.).

The presence of adherent concrete barriers on unfenced infrastructure, used at the centre of roads to separate the carriageways, or on only one side of the road, is particularly impactful, as these structures leave free access to all or part of the carriageway to fauna, while making it completely impassable. For some species, they can constitute a physical barrier which has the consequence of keeping individuals on the roads thereby increasing the risk of wildlife vehicle collision. In large-meshed fenced sections, mustelids* entering road coverage are also exposed to this risk (see sheet 21);

- **traffic:** the fragmentation effect increases with the number of vehicles;
- **the environments crossed:** the impact of the cut-off varies according to the type of environment (open, closed) and its quality.

The effects of fragmentation on the ecological network are diverse and can lead in particular to:

- the removal of access to initially used habitats;
- the modification of habitat conditions;
- the elimination of opportunities for dispersal;
- a brake on adapting the distribution of species to climate change.

■ **Removal of access to species' habitats**

The barrier created by the infrastructure can separate the different species' habitats necessary for the completion of their life cycles (removal of access to their feeding sites, to their breeding environments, etc.).

The level of impacts will then vary greatly depending on the presence, size and accessibility or not of alternative habitats:

- if alternative habitats are nearby and accessible, the impact is likely to remain low and the species will be able to maintain itself;
- if alternative habitats are remote but still accessible, the species will be able to sustain itself through longer movements. Depending on the

species, the increase in travel distances may be accompanied by negative effects on the energy balance and on natural evolution of populations;

- if alternative habitats are not available, if they are not sufficient in quality, or if they are too small, the species will have to leave the territory or decline.

It should also be noted that disturbances in one species may or may not affect all other species that interact with it. For this, it is necessary to take a "chain" and not simply a species-driven approach.

■ **The modification of habitat conditions**

The presence of an infrastructure can lead to changes in the ecological conditions of the environments crossed and lead to disturbances in the initial functioning of the environments and their role for the species. These disturbances may be related to:

- the opening of enclosed environments and the creation of edges. Local ecological conditions are modified compared to the initial habitat (exposure to the sun, wind conditions, temperature, etc.).



Habitat fragmentation effect
 Example of common hares on the Swiss plateau.

When the size of the habitat falls, population density decreases. Only areas larger than 100 ha allow the hare population to survive without depending on outside inputs. Isolated areas covering less than 30 ha do not allow a hare population to be maintained.

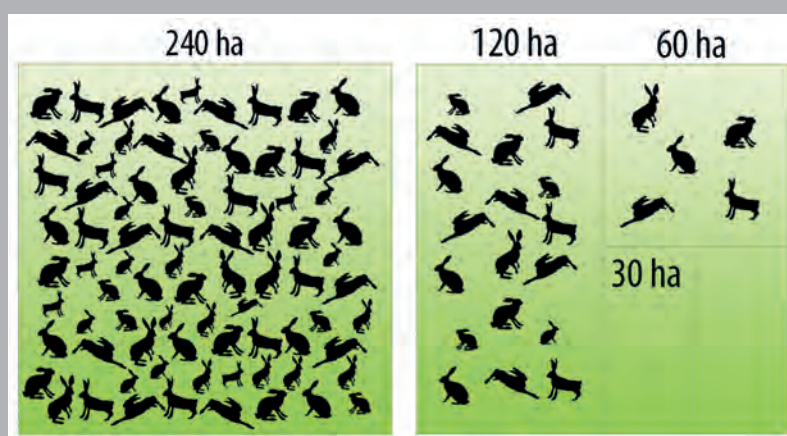

Source: R. Anderegg, "Routes et faune" day organised by the Swiss 'Office Fédéral des Forêts (1984)

These changes often result in the colonisation of new, usually more dynamic, edge-dependent species, to the detriment of generally more specialised "interior species". This results in a

steady-state depletion of the faunistic suite, even if, locally, the number of species present may prove to be higher (edge species + low-demand forest species);

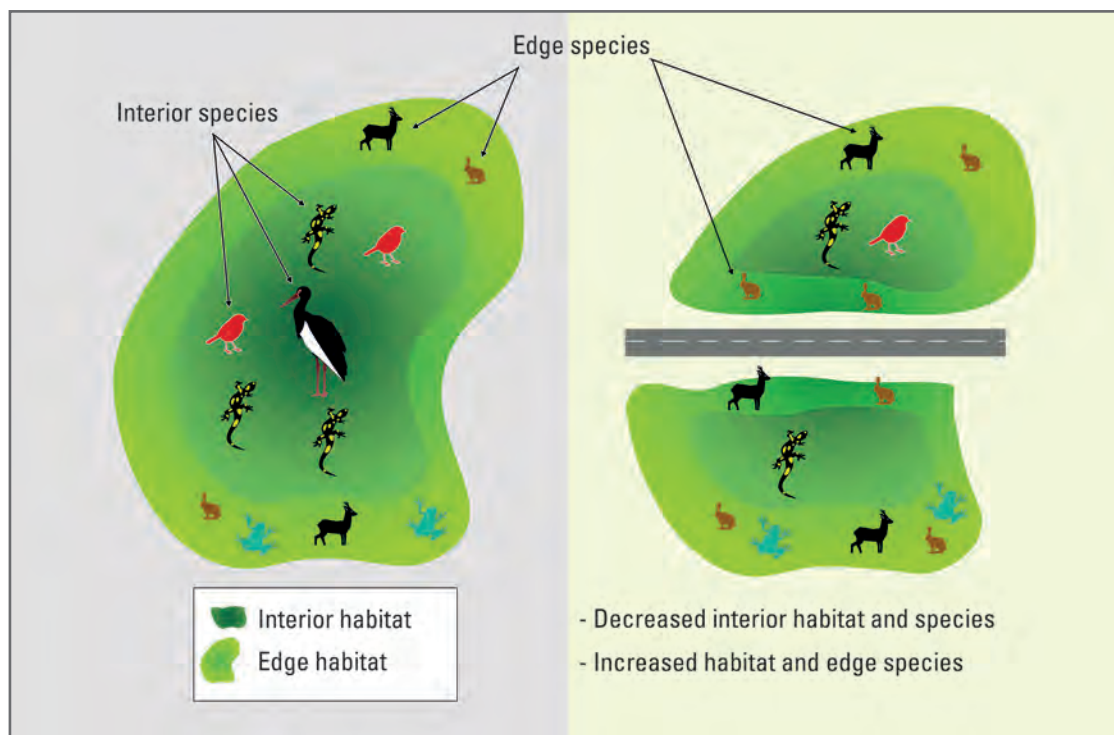

Impact of fragmentation of a wooded environment due to the edge effect.



In a forest environment, the area of habitats modified by the infrastructure, by the trench effect, is about ten times the width occupied by the road or track.

In this disturbed area, faunistic suites are then modified. R-strategist species (quick and massive reproduction strategy often with a high mortality rate) will develop to the detriment of k-strategist species (slow growth, long life cycle and low number of young) which are more sensitive to changes in the quality of habitats induced by the infrastructure.

Reduction of usable areas: qualitative impairment of residual areas favours r-strategist species to the detriment of k-strategist species

Source: cited by H.J. Mader - Melatt and delegated French Ministry of the Environment, "Routes et faune sauvage" colloquium (1982).

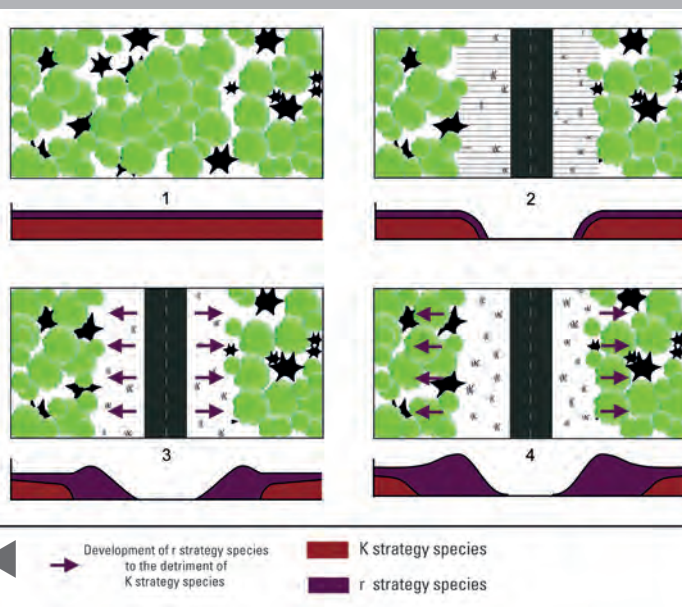

- the creation of noise pollution resulting from the flow of vehicles: their intensity varies according to the characteristics of traffic, the topography, the environment through which they pass, etc. This pollution can then generate stress reactions or simply the animal's escape far from the source out of fear, or because the sources of noise interfere with its acoustic communication, by masking it;



In the Netherlands, the density of birds decreases when traffic noise exceeds 50 dBA, whereas woodland birds are sensitive to noise levels from 40 dBA. Some species have the same reproduction rate in disturbed areas, but the survival rate of their young is lower (*COST 341 Report - Fragmentation des habitat due aux infrastructures de transport, 2007*).

- Artificial light at night: it acts as a barrier by causing breaks in darkness that may prove to be impassable for some species. Changes in the lighting conditions of a habitat can also have consequences on reproduction, the desynchronisation of biological clocks (the biological rhythm is no longer in phase with the environment), the predator/prey relationship or pollination.

■ The elimination of opportunities for dispersal

By affecting or even eliminating the possibility of species' movement, the infrastructure limits the processes of dispersal, i.e. the emigration of individuals from one population (usually juveniles) to another and concomitantly the contribution of individuals from one population from another (❶ below). The infrastructure can thus interrupt flows between favourable sites of species and prevent the colonisation of new habitats. The breakdown of the ecological network can then lead to a decrease in the genetic diversity of populations by lowering the rate of gene exchange within populations. It thus leads to a reduction in the genetic diversity of each of the local populations and greater differentiation between them (genetic drift). Over time, the likelihood of populations adapting to new environmental conditions decreases. The reduction of the genetic diversity of a population also increases its inbreeding and therefore the health risk in the face of an epidemic, which can also lead to its extinction.

Eliminating the possibility of dispersal can also lead to the disappearance of small satellite populations which can only be maintained by the contribution of incoming individuals.

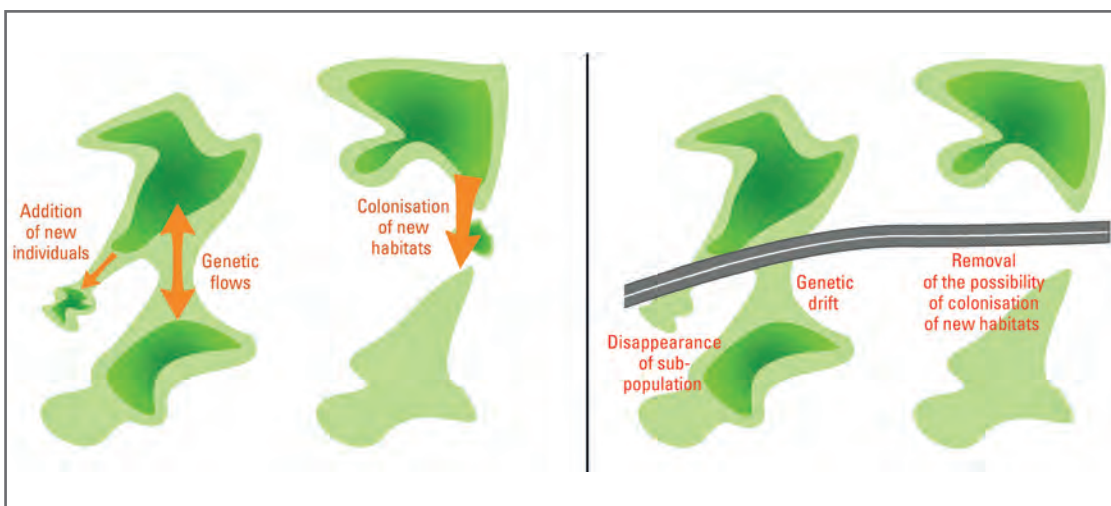

❶ Diagram of the impacts of an infrastructure on the dispersal of species. Source: Cerema.



Landscape genetics – Spatial structuring of deer populations around Paris: what is the role of transport infrastructure?

Vincent Vignon, Office de génie écologique (OGE).

This study was carried out on all red deer populations in the forests of Greater Paris to which the forests of the Oise department were added (Vignon & Suez, 2017). The interpretation of genetic analysis data has benefited from knowledge of the use of space by deer since the 1950s (Vignon, 1999).

Key results have shown, among others, that:

- a first level of genetic separation of populations determined by the cumulative effect of infrastructure: A10 motorway and LGV Atlantique, A5 motorway and LGV Paris-Lyon-Méditerranée or on both sides of the Seine, downstream of Paris (infrastructure and urban extensions);
- fauna passages seem to be effective. There appears to be a correlation between the levels of genetic structuring of populations and the use or not of passages, in particular in connection with the quality of the works on the various infrastructures.



Structuration génétique des populations de cerfs élapes autour de Paris (Ile-de-France et Oise)

La couleur ambre présente la répartition des populations de cerfs basée sur une modélisation (aires de migrations simulées). Les densités de cerfs/biches sont plus élevées dans les zones sombres.

Forêts :

- TE : forêt de Thelle
- NO : forêt de Chantilly
- NC : forêt d'Ermenonville
- NE : forêt de Compiègne
- VF : forêt de Villefermoy
- FT : forêt de Fontainebleau
- EE : forêt de Trois-Pignons
- EO : forêt de Bouville
- DO : forêt de Dourdan
- RE : forêt de Rambouillet « est »
- RO : forêt de Rambouillet « ouest »
- DR : du nord de la forêt de Rambouillet à la forêt de Dreux

Contour du premier niveau de structuration génétique

Sous-structuration génétique

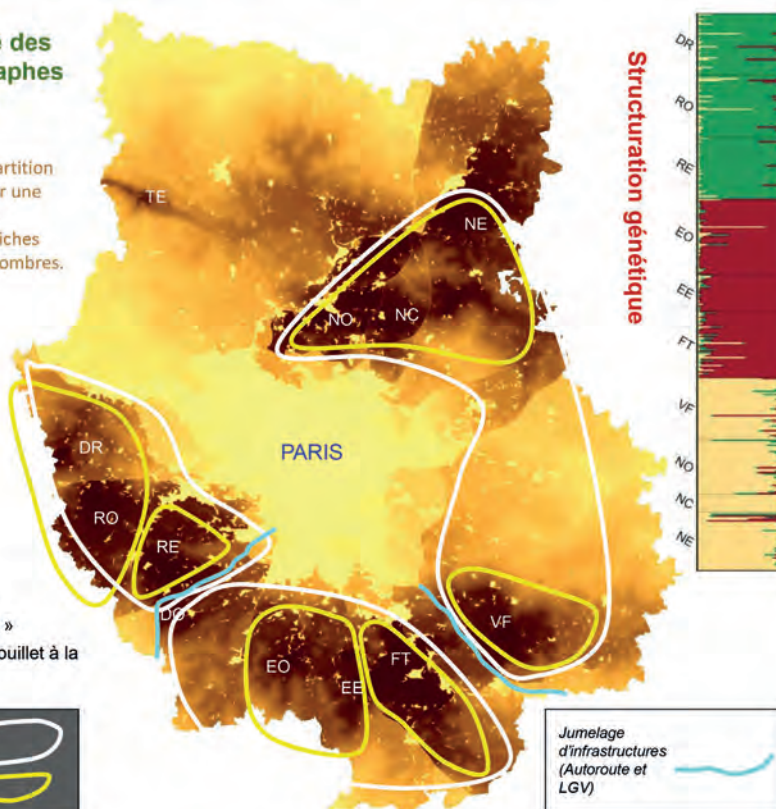

Jumelage d'infrastructures (Autoroute et LGV)



Metapopulation functioning*

All populations of the same species, separated by a spatial or geographical barrier, and for which there are more or less abundant and frequent exchanges of individuals and genes, constitute a metapopulation.

The survival or maintenance of a metapopulation depends on the quality of the connections between each of its populations. Thus, the ecological network plays a very important role in the conservation of metapopulations, whether through the quality and size of species habitats, biodiversity reservoirs* or the quality of areas of exchange and movement of individuals, biological corridors. The metapopulation as a whole may be stable, while some populations in the metapopulation fluctuate.

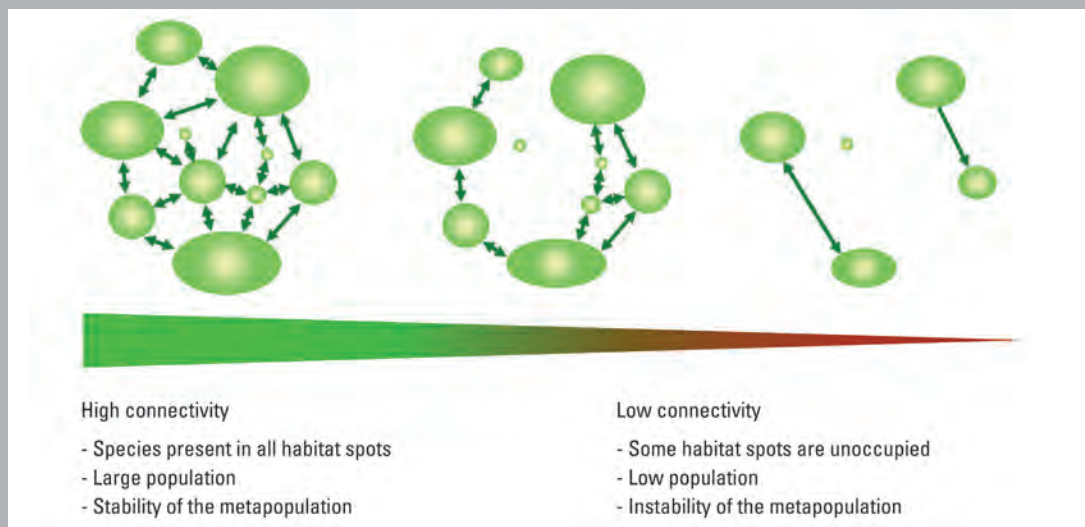

Biodiversity response to the fragmentation effect. Source: Pardini et al., 2010.

■ Reducing adaptation capacity of species to address climate change

Recent climate change (linked to human activities) is a complex phenomenon manifested by a wide variety of changes, which have already been shown to have an impact on biodiversity and to pose a threat to the survival of certain species.

Depending on the severity of the impacts of these changes, which take place at many organisational levels, the response of a population or species subject to the changes is however variable: either it **adapts** to the new conditions of its environment, or it **migrates** to find environmental conditions similar to those to which it was subjected before the changes, or

it cannot adapt or migrate and, in this case, it **dies out**, locally or generally.

Faced with climate variations that require fauna and flora to reorganise their distribution areas, maintaining the ecological network that allows species to move is essential to their adaptation to climate change.

In this way, the construction of an infrastructure, which constitutes a new obstacle* to the movement of species, represents a hindrance to the adaptation of species to these changes.

The infrastructure leads in particular to limiting the resistance and resilience* of species to disturbances. Specialist species with low mobility capacity will suffer the most due to their limited spatial adaptability.

Wildlife vehicle collisions

The amount of infrastructure, and in particular large-scale infrastructure (motorways, LGV - high-speed trains), has risen steadily since the 1960s, implying increasingly fragmented and isolated environments. In this context, a large number of animals, which are forced to cross an increasing amount of infrastructure to complete their life cycle within their home range* or to disperse, are victims of collisions with vehicles, both road and rail.

However, infrastructure-related mortality remains variable as follows:

- **species**, even if generally all are likely to be affected. The factors most closely linked to species include:
 - susceptibility to disturbance (species susceptible to disturbance are generally less affected, as they do not approach the infrastructure),
 - behaviour (many predators come to hunt at the edge of the infrastructure because of

the high number of micro-mammals* and insects on verges);

- the size of the species' territory (the larger the territory, the greater the risk of having to cross infrastructure to access all resources),
- dispersal capacity (the higher it is, the higher the risk),
- movement speeds (slow-moving species have a limited escape capacity and are therefore more exposed to the risk of wildlife vehicle collision);

- **seasonal rhythms**: a study carried out on the DIR Ouest network made it possible to highlight the seasonal variations in wildlife vehicle collisions specific to each species. Every year, the distribution of the number of wildlife vehicle collisions follows the same trend with a slight decrease during the winter months (see diagram on the opposite page). Closer study of wildlife vehicle collision data shows, for each species groups, a marked and similar intra-annual variability from year to year. Below are some examples of these peaks, the causes of which may be varied (behavioural factors, birthing, new generation swarming, hunting, etc.);

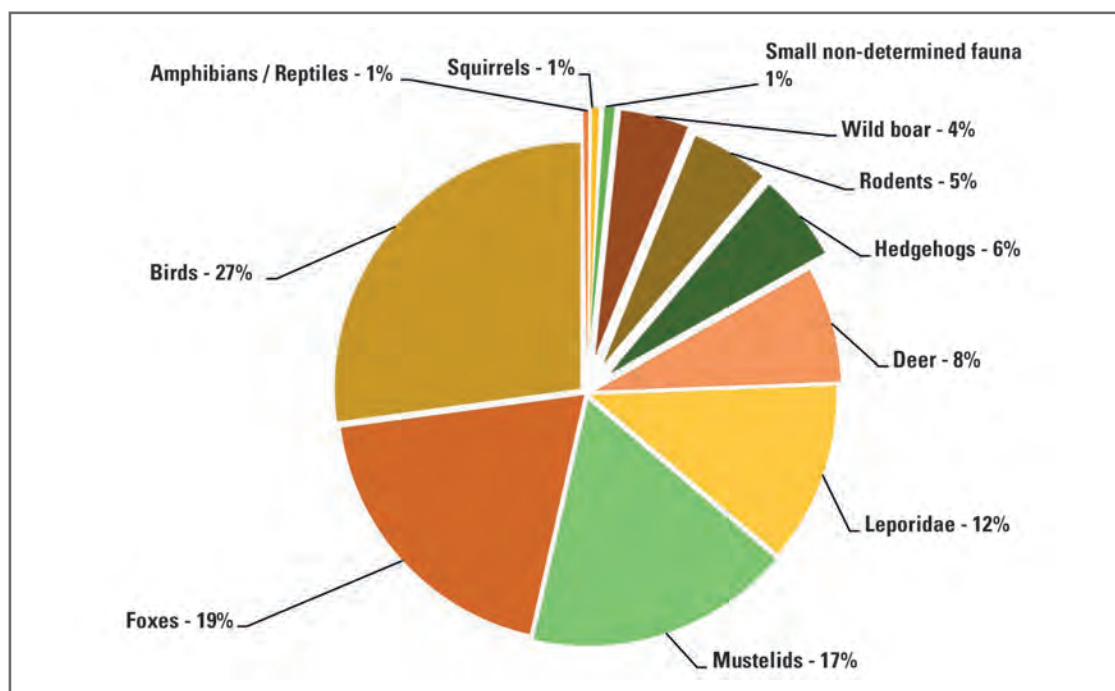

Annual distribution of collisions on the DIR Ouest network by species/species groups from 2014 to 2016. Source: Fauna/vehicle collision distribution analysis report. DIR Ouest. Data collected from 2014 to 2016, March 2018, UMS Patrinat, Lucille Billon.

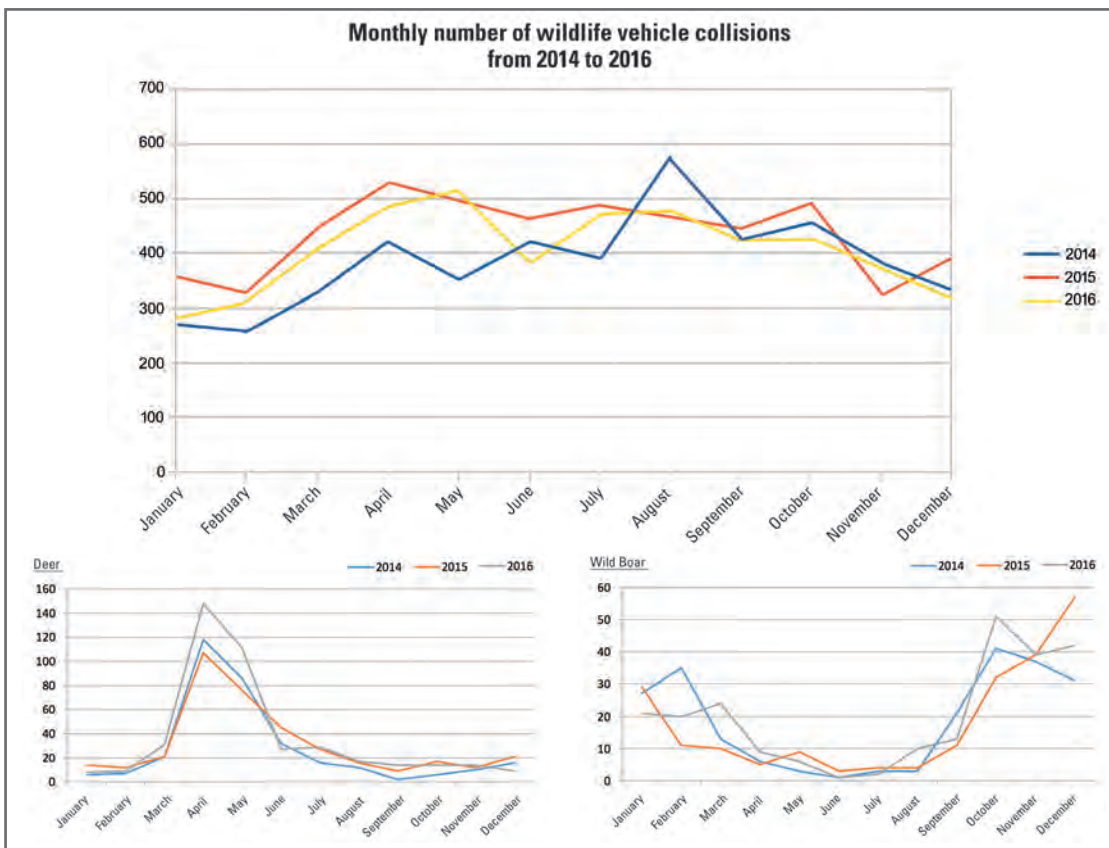

Monthly breakdown of collisions per year for roe deer and wild boar. Source: Fauna/vehicle collision distribution analysis report. DIR Ouest. Data collected from 2014 to 2016, March 2018, UMS Patrinat, Lucille Billon.

This trend is also observed on the national rail network, that is to say the LGV high-speed lines but also conventional lines. Wildlife vehicle collisions show strong seasonality:

- very high annual peak from mid-October to mid-January with hooved animals (deer and wild boar),
- deer-specific peak each year from April to June (slight lag depending on the year), corresponding to the period of search for new territories for young individuals, a phenomenon which may be accentuated by the consumption of buds in "drunk" deer, which are therefore less attentive.

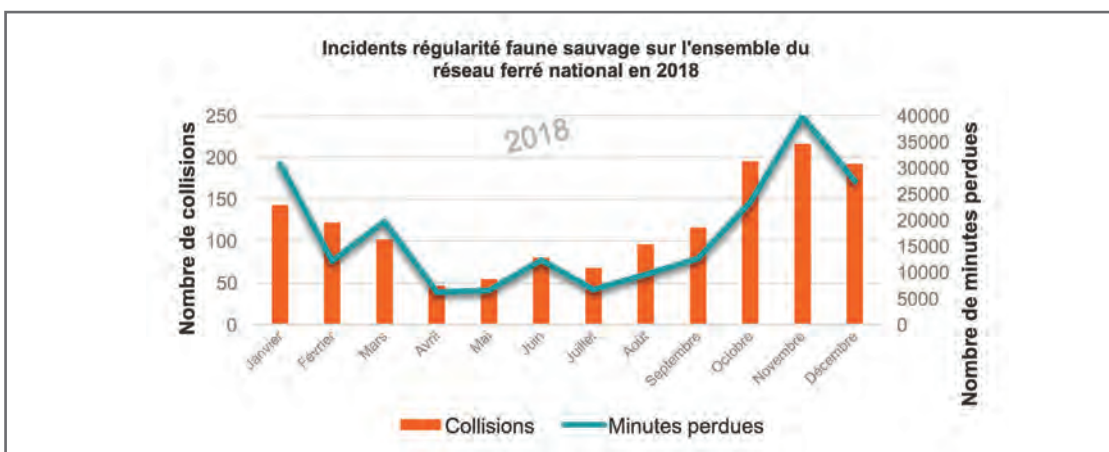

Graph of the distribution of recorded collisions and minutes lost related to wildlife across the entire national rail network in 2018. Source: Marine Le Lay, SNCF Réseau.

Another temporal variable is that of the time of day: collisions mainly take place at sunrise and even more at sunset.

Sunset also corresponds to the peak of traffic in the autumn (commuter trains after the working day).

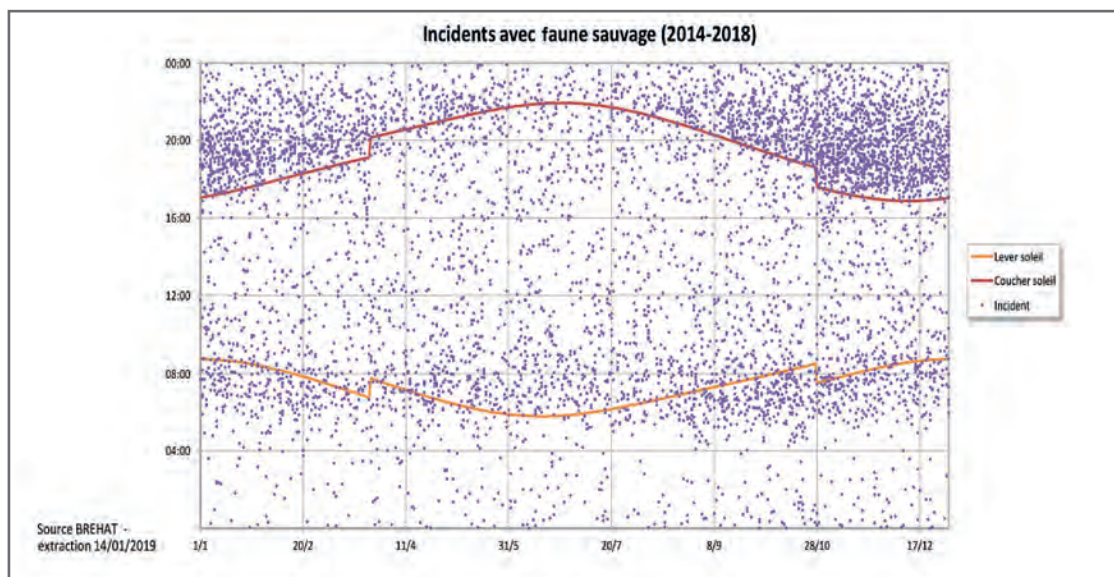

Graph of wildlife/train collision times during the year and curves of sunrise and sunset times. Source: Marine Le Lay, SNCF Réseau.

• **the characteristics of the infrastructure.** The risk depends in particular on:

- the width of the infrastructure: the greater the width, the greater the crossing distance, the greater the risk of collision,
- the width of green rights-of-way and their management, particularly in terms of maintaining the vegetation, as they can play a role in the attractiveness of the species on the edge of infrastructure or in the flight height of birds or bats (increase in flight above traffic in certain situations when trees are present),
- cross-sectional profiles (backfill, buried, combined, etc.), particularly for flying species. Profiles in light cuttings or at natural ground level are often the most impactful. This is not necessarily the case for mammals, particularly on railway infrastructure, where there seems to be more concern for problems encountered at large cuttings,
- the presence of fences that can limit the impact, preventing species from accessing the danger zone,

- the linearity of the infrastructure (curves generally offering poor visibility and hazard anticipation conditions);

• **Traffic and speed undoubtedly play a role in the level of impact.** The most accident-prone road infrastructure situations generally correspond to sections with low and rapid traffic. For slow-moving species, even when vehicle speed and traffic levels are low, the impacts on populations can be very significant;



Impact of traffic on amphibian populations

Source: J.J. Van Gelder (1973).

For a population of common toads having to cross an infrastructure, a traffic of 10 vehicles/hour eliminates 30% of migrating individuals*, 60 vehicles/hour eliminates 90% of migrants and 120 vehicles/hour kills 99% of the population. For the common frog that moves faster, the mortality rate reaches 50% for a traffic of 90 vehicles/hour.

• **the quality and structure of the environment passed.** The better quality and more welcoming the environment, the higher the potential number of animals, and the greater the number of individuals likely to cross the infrastructure. In this sense, ecological corridors crossed by an infrastructure generally constitute mortality black spots.

The vegetation structure on either side of the infrastructure can also play a role in guiding species towards danger (e.g. bats*, which follow landscape structures).

Wildlife vehicle collision can thus be very detrimental to the good conservation of populations, especially when those populations are small in number, are sensitive to the risk of collision (e.g. low speed of movement) and their reproductive dynamics are low (few young per year).

On the rail network, the impact can only be monitored at present through the monitoring of the regularity of rail traffic, which means that only events related to large animals are generally recorded.

While the assessment of the impact of infrastructure on natural evolution of populations remains very difficult to quantify, the implementation of monitoring or collision surveys, if sufficiently long (at least four years on motorways), carried out by patrol vehicles (on motorways) and supplemented by monthly monitoring over one year by an ecology engineer (source: COMERCAR project, ITTECOP, 2017), can give complete indications on the different size classes of fauna (small, medium and large) and on collision black spots. These indications, cross-checked with other data (population density on the territory, distribution of populations in connection with local naturalist associations, landscape ecology, presence or absence of civil engineering structures and fences, etc.) are useful for the environmental upgrading of networks through the development of a multi-annual program for the resorption of conflict zones. However, collision studies alone are insufficient to position civil engineering structures. A more comprehensive study of the ecological network must support the process.



In order to achieve national homogenisation, MNHN, building on the work conducted by Cerema Ouest for DIR Ouest, published, in 2015, a Protocol for the census of collisions between wildlife and vehicles. It can be applied by infrastructure managers and other structures wishing to study wild fauna/road conflict points.

A second document presents the methodology for analysing collision data, in order to detect points of conflict between fauna and roads.





Synthèse des zones de forte agrégation de collisions faune/véhicules - DIR Ouest 2014 - 2016

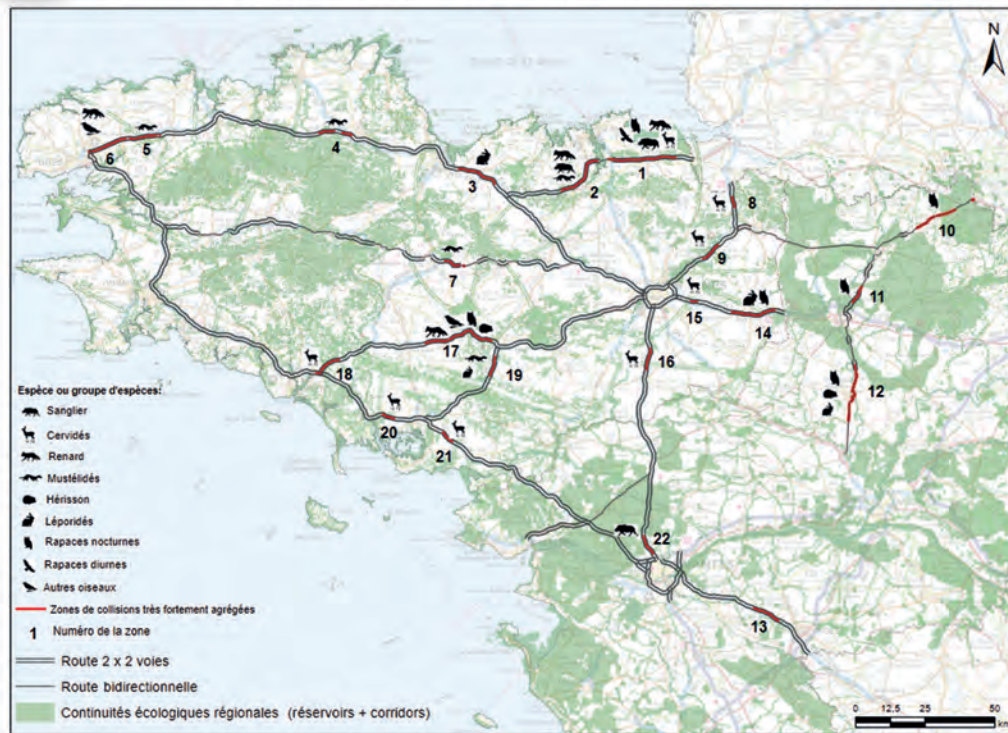

Source: Fauna/vehicle collision distribution analysis report, DIR Ouest. Data collected from 2014 to 2016, March 2018, UMS Patrinat, Lucille Billon.

The imperative of passenger safety

Beyond the impact on biodiversity*, the issues of collisions with fauna also affect the safety of users of transport infrastructure. In France, between 2008 and 2010, according to data from the police and gendarmerie, nearly 500 accidents with wild animals (around 170 per year) were recorded, resulting in 35 deaths (about 12 per year), 350 hospitalised injuries (about 115 per year) and 200 minor injuries (about 65 per year). On the rail network, nearly 1,500 collisions are recorded each year on the national territory, generating nearly 200,000 minutes lost on 8,000 trains. Depending on the species in question, on a frontal or side impact and on the type of rolling stock, collisions can cause very significant material damage, posing

a threat to the safety of traffic and persons and potentially leading to the transfer of passengers.

The number of accidents has also tended to increase for many years. A census carried out between 1984 and 1986 by the Highways Department of the Infrastructure Ministry reported 11,055 collisions with fauna over those three years (less than 4,000 per year). In 2008, the number of accidents caused by wild animals was around 35,000, more than 60% of which were big game (36% wild boar, 17% roe deer, 8% deer). From an economic point of view, according to a study conducted by the OFB, it is estimated that collisions with large ungulates cost between 115 and 180 million euros for about 23,500 collisions (Vignon and Barbarreau, 2008).



Impact of collisions on rail infrastructure

On the rail network, collisions with large fauna are numerous and cause significant damage to rolling stock with repairs requiring its immobilisation and significant expense (up to 70,000 € for a collision). These accidents can also weaken infrastructure and cause many delays and cancellations of trains (inspection after collision, replacement of damaged machinery, transfer of passengers to another train, etc.).

Some figures:

- the number of incidents involving big game is constantly increasing. It rose from 1,027 in 2014, to 1,132 in 2015, then 1,280 in 2016 and finally 1,432 in 2018;
- the average full cost of a collision occurring on LGV lines is around 100,000 €. These costs include delays, supplies and labour for the repair, immobilisation of the impacted rolling stock, that of on-board staff and compensation paid to passengers.

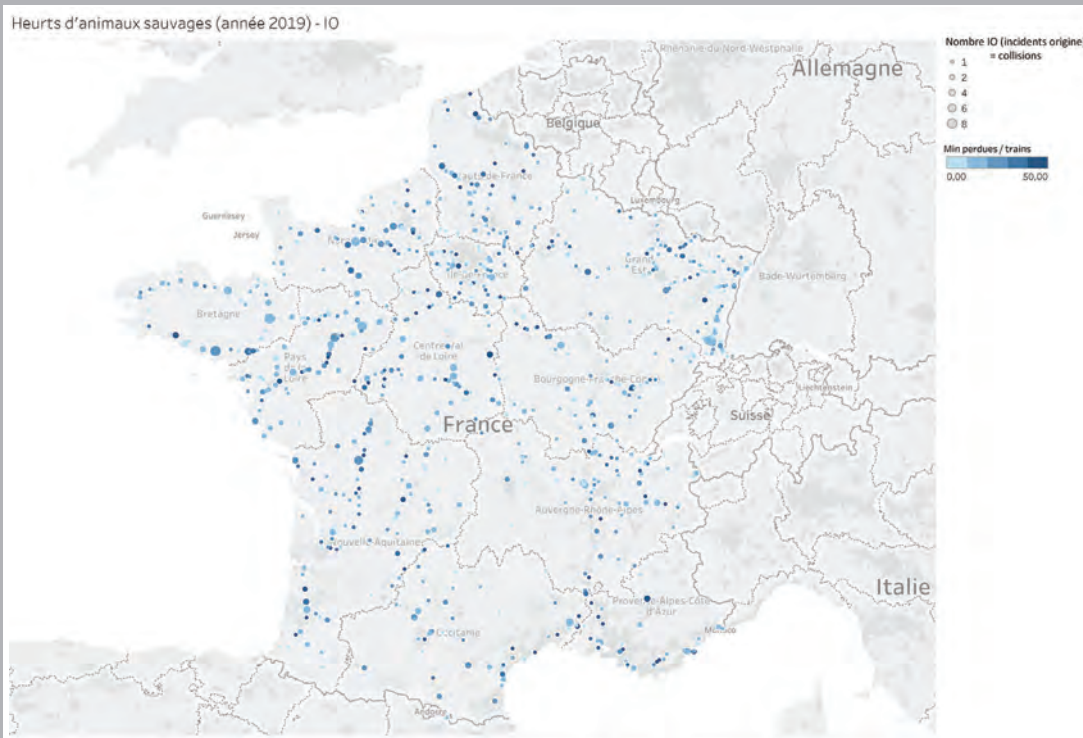

Map of rail collisions involving fauna in 2019. Source: Marine Le Lay, SNCF Réseau.

Finally, it should also be noted that in the event of an accident caused by the passage of large wild animals on public roads, the road management company may be held liable for lack of normal maintenance or signalling.

Taking into account the ecological network that supports a large number of fauna movements is therefore a necessity to ensure the safety of users and limit the economic cost of accidents.

How to provide an effective response to the disruption of the ecological network?

Re-establishing transversal and longitudinal continuities

One of the main impacts of infrastructure is the barrier effect it poses to the movement of fauna. While it is not technically or economically possible to restore all crossing possibilities for all species along infrastructure, it is possible to limit the impacts of fragmentation and ensure minimal permeability by constructing crossing structures for fauna (see Part II). These structures are designed and built taking into account the specificities and interest of the habitats crossed as well as the species concerned, through the analysis of the ecological network that has been broken.

A fauna passage restores crossing possibilities of varying degrees of efficiency depending on its size,

the environments present, the development, etc., but in all cases, this restoration is done only at a given point. It is therefore necessary to ensure the proper design of the passage, but also to promote its use by taking into account the structures to lead fauna to this structure. In this sense, the green rights-of-way of the infrastructure, that is to say the vegetation areas bordering the infrastructure can constitute this stopping point and facilitate the movement of species along the infrastructure through to fauna passages, provided however that the installation of fences allows it (which is not always the case when they are positioned at the road coverage boundary).

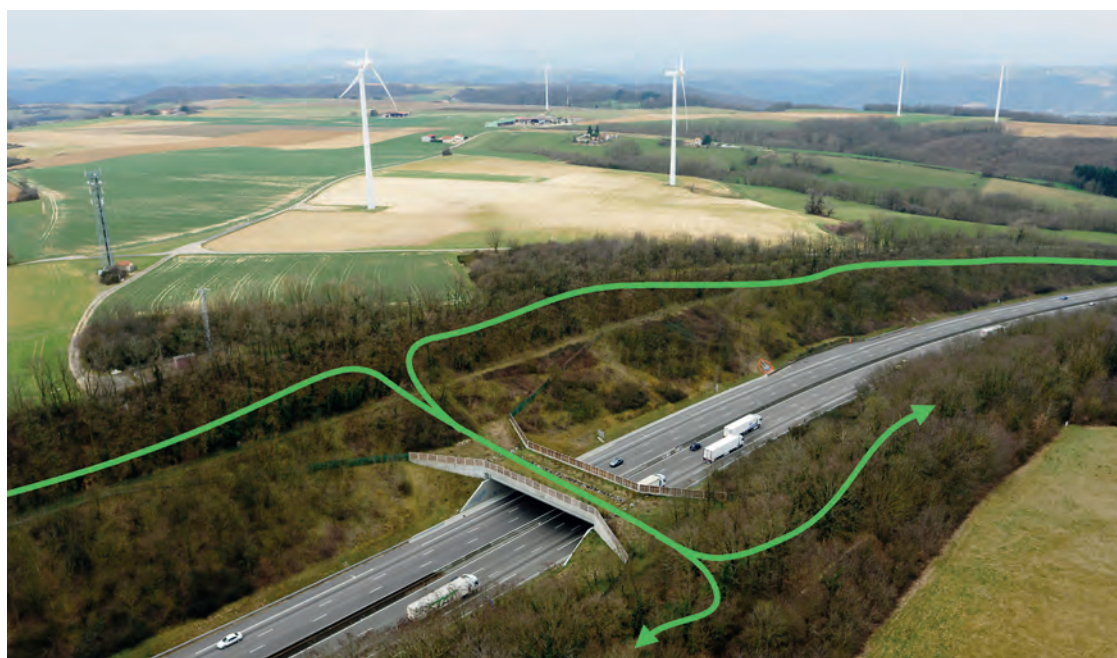

Example of green rights-of-way that support travel along the infrastructure to the fauna passage. Source: Alterra/Vinci Autoroutes.

Integrating the ecological network during the different stages of the project

Transport infrastructure projects are rolled out in successive phases, each with a specific objective. In the case of a new project, the territory studied is increasingly restricted as the phases progress (progressive nature of studies). The degree of precision of the investigations of these different studies, however, depends on the importance of the project in terms of scale. The larger the scope of a project, the larger the study area. A project of several tens or even hundreds of kilometres is not apprehended in the same way as a project covering a few kilometres.

As the study area is generally more restricted for upgrading projects* than for new projects, the following chapters will deal mainly with new projects. The particularities of upgrading projects will be covered in the comments.

The Government's instruction of 8 November 2018 on the procedures for preparing investment and management operations on the national road network established the need for an opportunity decision authorising works on the national road network or for works planned by a third-party contracting authority (local authority, concession company, etc.) impacting the national network.

The technical instruction sets the framework and sequence of studies necessary for the implementation of these projects.



For projects of a third-party contracting authority not impacting the national road network, even if the different phases of studies can be resumed, there are no particular obligations before the *Déclaration d'utilité publique* file.

Opportunity studies

This is a set of studies that aim to progressively verify the relevance of an infrastructure project to meet an identified mobility need and to outline its main characteristics.

Three levels of study have been defined:

- route opportunity study;
- phase 1 project opportunity study;
- Phase 2 project opportunity study.

Route opportunity study

The main objective of route opportunity studies, on a given territory, is to specify mobility need(s) and to deduce **a long-term development plan** [A next page] to meet this need. The whole transport system, including the entire road network and its connections to other modes, must be reviewed.

The development part will then be broken down into different individual operations (e.g. deviation, widening, etc.) that can be prioritised to define one or more road development projects to be favoured in the short or medium term. [1 next page]

■ Taking the ecological network into consideration

The analysis is at this level quite simple and essentially bibliographic. The objective is above all to take into account the current status and in particular to make an analysis of the network from the point of view of any existing breaks.

This analysis must also make it possible to take into account the negative consequences of the different developments on the ecological network. It thus participates in the comparison of network variants, in the choice of the preferred route variant and its subsequent implications [B].

For example, the main focus here is to take into account the documents and maps of the SRCEs and the new SRADDETs replacing the SRCEs, as well as - depending on the size of the project - the green and blue grid* of the SCoT and the PLU(i) if available. It is also advisable to contact naturalist organisations that may have data on the area. Care must be taken to distinguish the constituent elements: ecological network, biodiversity reservoirs* and corridors, the latter being more likely to be crossed than the former. Additional information on protection perimeters (generally integrated into biodiversity reservoirs) may be provided to specify certain levels of constraints.

Phase 1 project opportunity study

Phase 1 project opportunity studies (called "functional pre-studies" in the railway field) concern an **identified development project (or operation)** [C next page]. Their objective is to decide on the advisability of the operation, i.e. both on its interest value, its feasibility and the conditions for its continuation. This study phase must specifically make it possible to know whether, in view of needs (mobility, reduction of nuisances, etc.), the proposed road (or rail) project provides a proportionate and relevant response, and whether it is feasible.

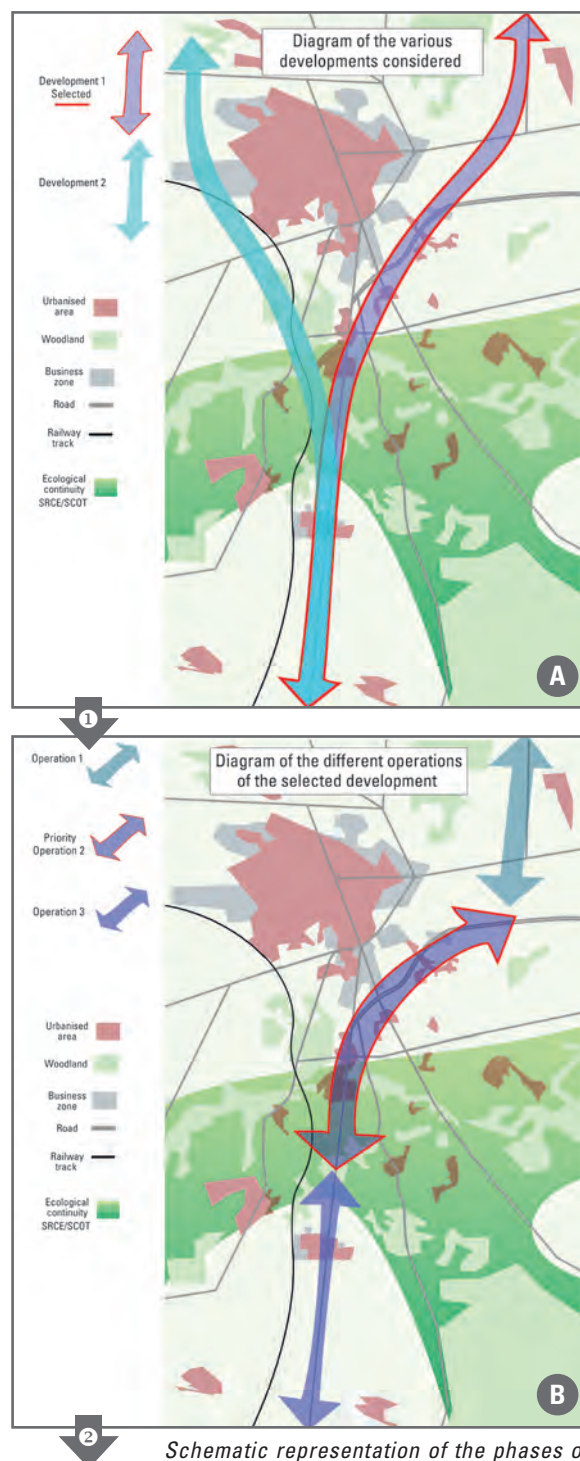

Schematic representation of the phases of a route opportunity study. Source: Cerema. Diagram A: route variants. Diagram B: route chosen with differentiation of development operations, including the route considered a priority.

When several projects have been identified ②, this phase must allow the identification of the priority option. ③

■ Taking the ecological network into consideration

As in the previous phase, issues and potential impacts on the environment and biodiversity* are mainly identified on the basis of existing data (habitats, species and regulatory or non-regulatory zoning). A field survey plan for the next phase can also be drawn up and surveys in poorly known areas can be carried out at this stage, in order to better support the decisions of the contracting authority.

The approach of taking into account the ecological network, particularly in terms of breaks, is usually identical, except that it is carried out on the level of a development project and no longer on the level of a development part. Data analysis can refine the boundaries of known continuities, depending on the scale of the project.



Case of upgrading projects*

This type of phase is not frequent and the next phase is usually directly reached.

Phase 2 project opportunity study

Phase 2 opportunity studies, relating to a **precisely identified infrastructure project [D]**, make it possible to choose the best development solution, particularly in terms of crossing the territory, and to determine the main technical characteristics. It is a progressive approach which, at each stage, helps reduce the geographical area in order to limit the scope of studies.

Their purpose is thus to specify the issues affecting the operation, to present one or more groups of development variants that meet the issues identified and to lead to the choice of a preferred variant that will be brought to the public inquiry*.

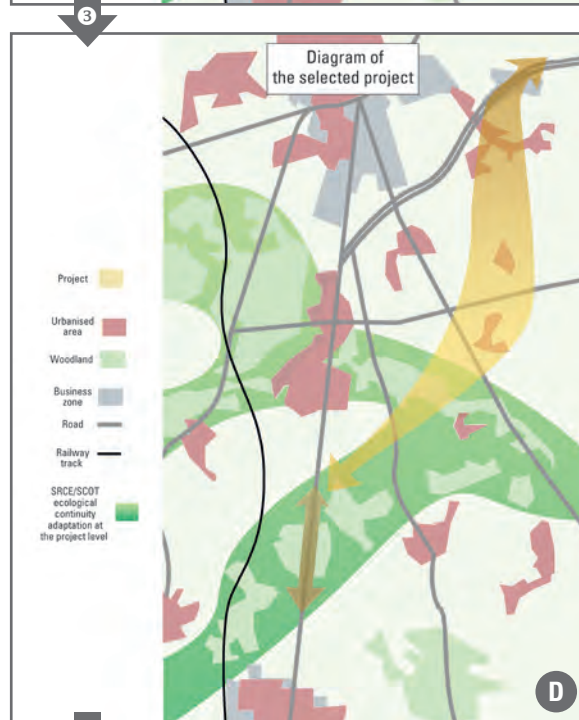
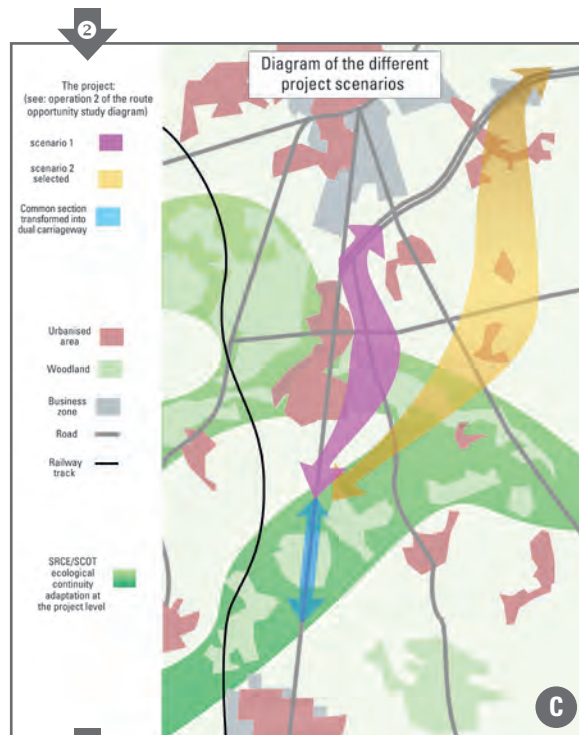

Schematic representation of the phases of an opportunity study. Source: Cerema.
Diagram C: different project options envisaged for an operation regarded as a priority ①.
Diagram D: selected project.

Development principles can be determined at this stage (e.g. abutment of waterway structures on permanent watercourses at least 3m from the edge of the banks).

The phase 2 opportunity study is carried out in a study area [E] defined according to previous orientations and the nature of the operation envisaged (it can be for example very extensive in the case of a project with a new route, or reduced to a narrow strip on either side of an existing infrastructure to be enlarged).

On the basis of this study area, especially when it is a new route, the analysis is done in three stages:

- a first stage that aims progressively to reduce the study area to one or more **passage corridors** [F] within which the technical characteristics may be examined in more detail. This is a rough outline of the operation on the basis of existing maps (1/25,000, 1/50,000 or 1/100,000 depending on the size of the operation).

■ Taking the ecological network into consideration

During this first stage, the ecological network will be taken into account on the basis of existing maps (SRCE, SRADDET, ScoT, PLU(i), green and blue grid studies*...) and will integrate the other warning perimeters (ZNIEFF, Natura 2000*...), even if normally the latter are already integrated into the mapping of the previous stages. Finally, this first approach can be supplemented by a simplified cartographic analysis of land-use, with a view to identifying the major natural continuities that have not been included in existing data or that already seem self-evident;

- a second stage where, within the passage corridors, the actual variants will be studied [G next page] on the basis of a more precise and advanced data collection, including field prospections.

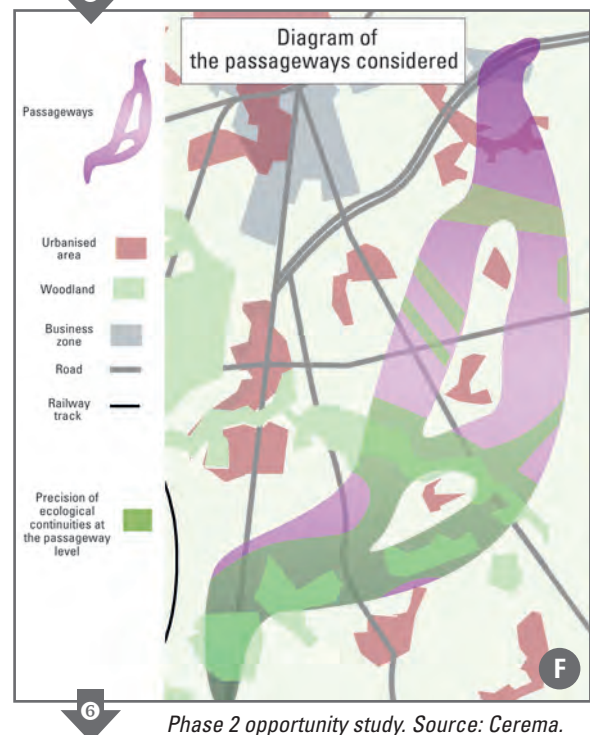
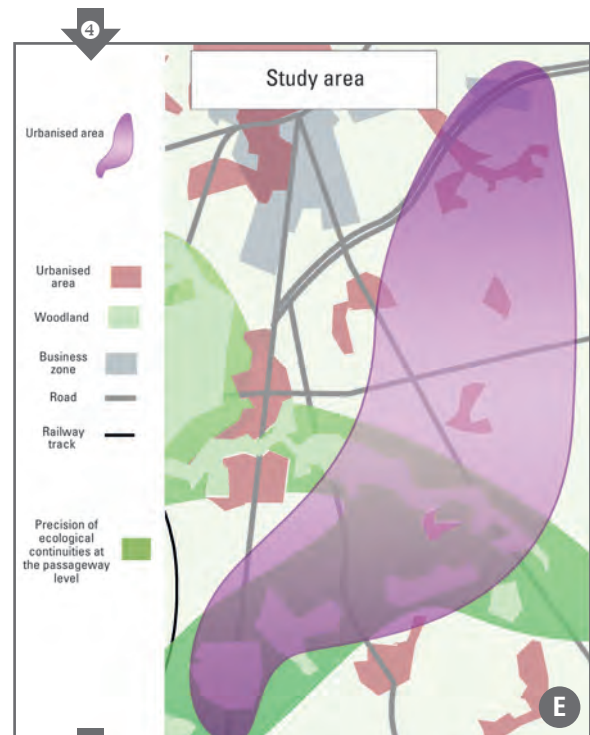

Phase 2 opportunity study. Source: Cerema.
Diagram E: project study area.
Diagram F: envisaged passage corridors.

These studies are to be conducted at scales ranging from 1/10,000 1/5,000 or even 1/5,000 to 1/1,000 for on-site development.

■ Taking the ecological network into consideration

The second stage is based on an analysis of land-use, previous naturalist data, elements of the regional green and blue grid* and the first precise field inventories of natural habitats and species* (flora and fauna). It aims to identify and map the ecological network on the level of the chosen zone (adaptation of the TVB). This involves taking the elements of the SRCE or ScoT by adapting and specifying them locally, then completing them by identifying the whole ecological network of more local issues not covered in the planning documents and already initiated during the previous phases.

A multi-criteria analysis will then make it possible, after consultation, to define the most appropriate solution (variant of the 300m section) to be submitted to the inquiry prior to the public declaration [H]. This analysis is carried out on the basis of a set of technical, economic, social and environmental factors.

This phase will have to include a prioritisation of specific issues related to natural habitats and the ecological network. The prioritisation of solutions must be made by qualitative and quantitative comparisons by retaining relevant indicators related to the foreseeable disappearance of habitat areas in the different zones, the reduction of already fragmented territories, the minimum areas to be conserved for the survival of species and the break in strong functional flows.



Case of upgrading projects*

The elements included are identical to those of a new project except that the study area is centred around the existing structure.

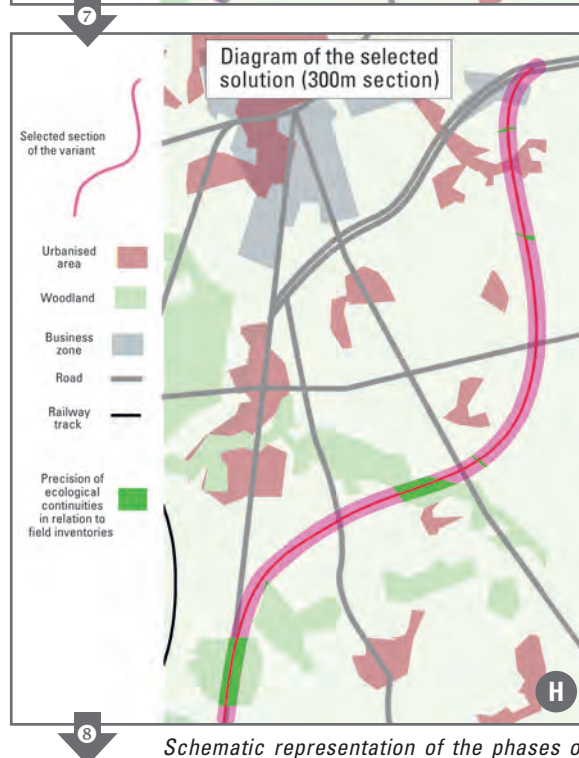
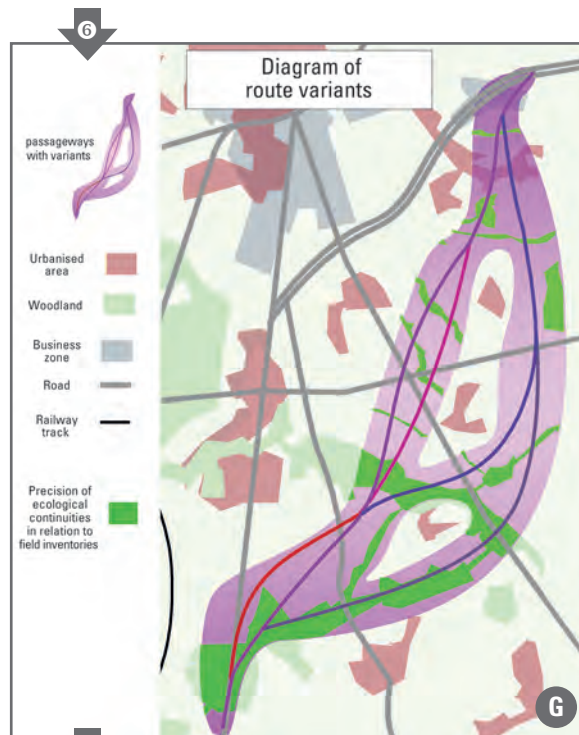

Schematic representation of the phases of an opportunity study. Source: Cerema.
Diagram G: Variants of envisaged routes
Diagram H: Chosen route variant.

Prior studies (to the public inquiry*)

Based on the preferred variant following the phase 2 opportunity studies, studies prior to the public inquiry* aim in particular to determine the main technical characteristics, which must comply with the instructions in force and best practices, and to determine the impacts and measures to avoid, reduce, or offset* these impacts.

This includes precisely defining to the nearest few hundred or even tens of metres the route that will be submitted to the public inquiry. The study of the chosen variant can still in this way be subject to localised adjustments. At the end of this preliminary study phase, the study route presented in the DUP (Déclaration d'utilité publique) will be chosen.

■ Taking the ecological network into consideration

At this stage, the aim is to take stock of natural habitats (and habitats of species) of heritage value (EUNIS codification) and to ensure the functionality of the ecological network, in particular through field verification, throughout the study area, and in particular at intersection points with the reference lines, in areas detected in the knowledge gap or, failing that, in all areas presumed to be sensitive.

A more accurate, complementary and specific analysis of the ecological network necessary to maintain certain species or processions of heritage species, and in particular protected species, can also be conducted. In the case of protected species, this analysis makes it possible to complete the "protected species derogation" file.

The essential characteristics of the project and the associated measures in favour of fauna are indicated quite accurately, to the nearest hundred meters or so. The file, among other things, includes measures to maintain the transparency of the infrastructure for the fauna, especially on networks identified during the previous phases (and specified if necessary at this stage of the studies) 8.

Fauna passages are therefore localised, their function described (passage for all, specific, combined, small fauna passage, etc.) and their sizing is defined. The precise sequencing and methods of their construction and implementation will be specified during the subsequent phases of the project.

An analysis of the longitudinal continuities that can be re-established must also be carried out, taking into account the habitats that may be recreated and the fencing systems associated with the structures.



Case of upgrading projects*

The elements included are identical to those of a new project except that the study area is centred around the existing structure.



Preliminary studies: schematic representation of the route of the infrastructure in a plan, with ground entrances, position of fauna passages, etc. Source: Cerema.

Déclaration d'utilité publique (DUP)¹ including the impact study

The DUP (*Déclaration d'utilité publique*) acts as the project declaration as laid down by article L.126.1 of the French Environmental Code*. The file includes several documents (subject of the inquiry, site plans, explanatory note, general layout of the works) and in particular the impact study, which is an essential document (if the project is subject to environmental assessment²).

The impact study is the **summary** of the environmental studies carried out from the decision taken on the advisability of the project through to the launch of the investigation prior to the project declaration or *Déclaration d'utilité publique*. The procedures that have been carried out make it possible to describe and assess the significant effects of a project on all areas of the environment, including natural environments, fauna and the ecological network, and to justify the objectives and reasons that led to choosing the solution.

The impact assessment must be sufficiently succinct, clear and well-argued to prepare the public inquiry*.

Its content (Article R.122-5 of the French Environmental Code*) is extensively detailed in Cerema's methodological guide, *L'étude d'impact dans les projets d'infrastructures linéaires de transport (Impact study in linear transport infrastructure projects)*, published in 2016.

This impact study is carried out in a proportionate, progressive and iterative way throughout the project, in order to take into account the environment and adopt the least impactful solution.

While the initial state of the environment is based on preliminary study files, further study may be necessary on certain themes or geographical sectors, if major issues are likely to be impacted or when the level of information is insufficient.

The cartographic scales are identical to those mentioned in the studies prior to the DUP (*Déclaration*

d'utilité publique). However, thematic or geographical focuses must make it possible to analyse the major issues with precision, the impacts on the environment and in particular the cumulative impacts with other known projects and the measures to avoid, reduce and offset* the negative effects.

Monitoring mechanisms (including the use of passages) are also already defined.



Case of upgrading projects*

The elements to be included are identical to those of a new project.

The table appended to Article R.122-2 of the French Environmental Code* also applies to modifications or extensions of existing transport infrastructure. Modifications or extensions of an existing structure or development, not specifically explained in the table, are the subject of an impact study, systematically or after examination on a case-by-case basis.

The impact study (or the ecological diagnosis attached on a case-by-case basis) must contain sufficiently recent data or considered to be still up-to-date (the Conseil National de Protection de la Nature, CNPN, recommends an update after 3 years, if the project is the subject of a request for derogation under protected species).

State commitment file (State project)

The State commitment file (necessary for the project files of the national road network) constitutes the exhaustive inventory of the formal commitments explicitly made by the State, which must therefore be followed as such during the execution studies and then the implementation, to set up an internal and external control (monitoring committee). It follows that the file must be strictly faithful to all the commitments entered into, both in terms of their content and of their level of precision.

¹ When there is no expropriation, there is a project declaration (with impact assessment).

² See Appendix R.122-2 of the French Environmental Code concerning 52 development categories subject to Environmental assessment.

It is generally not appropriate to elaborate on the details of certain provisions, as the project as a whole has not reached a sufficient level of definition at this stage.

The ecological network taken into consideration includes:

- in terms of objectives or results, defining the level of transparency to be ensured with respect to fauna;
- in terms of conditions, for example specifying the nature of any additional studies;
- in terms of resources:
 - to create fauna passages without having to completely size them. In these cases, the passage is localised and defined in principle,
 - respecting certain specifications such as the development of all waterway structures for terrestrial fauna, the possibility of small fauna passages every 300m.
 - the type of fences, etc.



Case of upgrading projects*

The elements to be included are identical to those of a new project.

Preliminary study

The preliminary study sets the final route of the infrastructure, specifies the characteristics and dimensions of the structures of the chosen solution and makes it possible to deepen certain environmental measures provided for in the impact study. The file incorporates the commitments made in the previous phases (public inquiry*, State commitments). This preliminary study phase is only necessary when there is a concession at stake or private project management.

■ Taking the ecological network into considerations

The preliminary study for the environment finalises the choice of position and characteristics of fauna passages in line with the other sub-files and in consultation with local partners. It specifies: the structure of the structures, their inclusion into the landscape and the sketch of the landscaping, the modelling to define the quantities of materials to be used, the cost and the accompanying measures (fencing, screen, devices to direct the fauna to the structure, monitoring mechanisms such as track traps, photo traps, etc.).

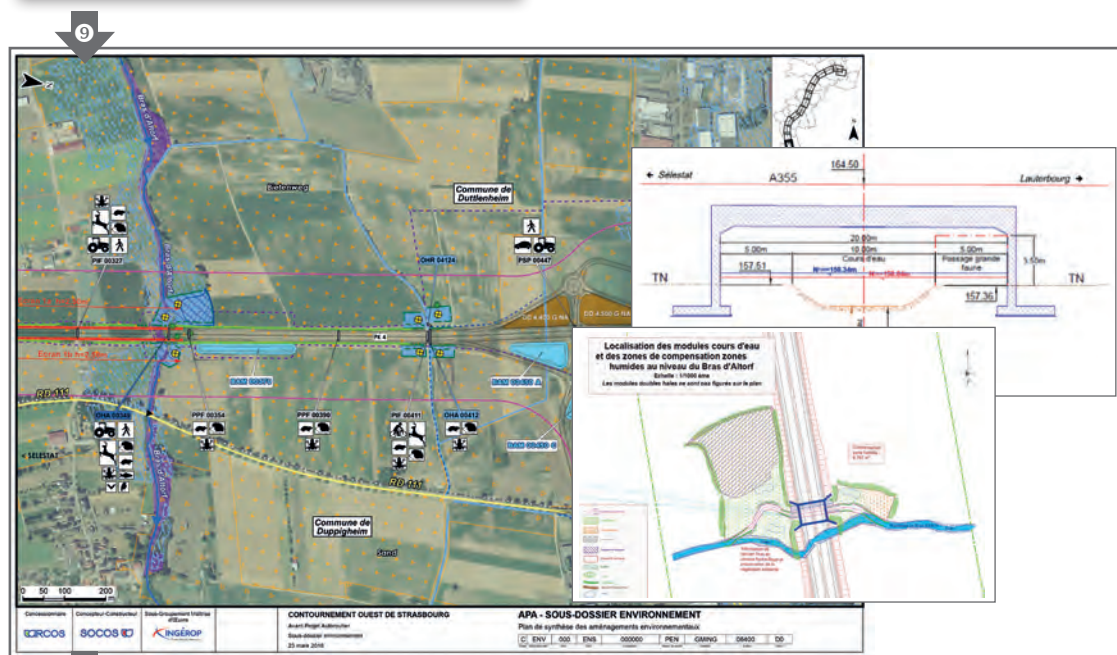

Example of the documents submitted as part of a preliminary motorway study.

Ground plane of the measures provided at the crossing of the Bras d'Altorf. Typical cross-section of the watercourse structure and schematic representation of the proposed ecological developments on the watercourse. Preliminary motorway study for the western bypass of Strasbourg. SOCOS/SINBIO. 2018.

The management plan for fauna crossing structures is specified at this stage.

Within the framework of structure coverage, the approaches to the passages can be managed through an agreement. Outside the framework of structure coverage, land tenure problems can complicate the implementation of management. In this case and as part of the preliminary motorway project (APA), it is possible to acquire additional road coverage at the passages to master possible evolutions, before land acquisition procedures. For trunk roads and motorways under private management, acquisitions may go beyond the 300m band, in order to acquire additional road coverage benefiting from a protective easement.

The maps must be precise to a scale of 1/500 to 1/200.



Case of upgrading projects*

The elements to be included are identical to those of a new project.

Detailed design study: project study

Project studies make it possible to precisely define the detailed technical characteristics (geometry) of the project, its exact footprint, road repairs, engineering structures, etc.

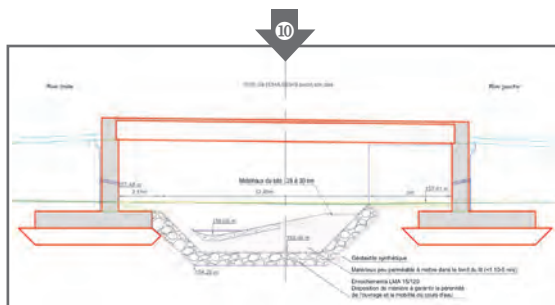

Cross-section of the Bras d'Altorf structure and ground plane of the ecological developments on the watercourse. Project study for the western bypass of Strasbourg. SOCOS/SINBIO.

At this stage, the necessary land acquisitions are made. The project must also integrate the environmental authorisation at this level (see next chapter).

■ Taking the ecological network into consideration

The execution study aims to define in great detail the technical and architectural characteristics of the fauna passages to be built and roadside development, so that civil engineering contractors can implement the project without necessarily requiring the help of a design office specialised in ecological engineering.

The execution file includes the description of the structures, their technical specificities and their accompanying measures (soil modelling, type of fencing and location, plant development, track traps, etc.), the special technical clauses and a precise price schedule.

The 1/200 cartographic information and the plans detail the characteristics of the structures: elevation, plan view, cross section and long section and the roadside development: details of the earthworks, choice and density of plants.



Case of upgrading projects*

The elements to be included are identical to those of a new project.



Environmental authorisation file

For installations, structures, works and activities (known as IOTA) subject to authorisation under the French Water Act, a single integrated procedure called "environmental authorisation" is implemented, bringing together all the administrative documents needed for the implementation of an IOTA project. Without this authorisation, work cannot start.

The environmental authorisation file includes the elements from the previous files, specifying them to meet the regulatory requirements of the French Environmental Code*, in a detailed, precise, technical and measurable way.

For infrastructure projects requiring authorisation under the French Water Act, the environmental authorisation dossier must bring together the Water Act authorisation and, where necessary, the clearing authorisation, the protected species derogation, the Natura 2000 impact study*, the modification of the status of a nature reserve*, etc.

Section on the Water Act

The nomenclature determined by Article R214-1 of the French Environmental Code defines the operations subject to authorisation or declaration prior to their commissioning. New projects are almost systematically subject to a Water Act authorisation application. The corresponding file must take into account all impacts on aquatic environments, including during the construction phase and due to exceptional conditions (e.g. accidental pollution).

In terms of ecological network, the project must in particular ensure the free movement of aquatic organisms (aquatic fauna including fish and semi-aquatic fauna) towards the compartments essential to the completion of their life cycle* (feeding, reproduction, rest, growth), the natural transport of sediments from upstream to

downstream of a watercourse and the proper operation of biological reservoirs (connections and favourable hydrological conditions).

Section on protected species

The content of the application file is detailed in Articles R.181-12 to R.181-15 of the French Environmental Code.

Article L411-2 of the French Environmental Code provides for three criteria to be met to submit any request for derogation from protected species:

- the project must justify imperative reasons of overriding public interest;
- it must justify the absence of satisfactory alternatives;
- the derogation must not affect the maintenance of species in their natural state of conservation in their natural distribution area.

After having carried out a precise assessment of the initial state of the species concerned and quantified the impacts, the project promoter must thus demonstrate (through ARO measures) that the project ensures the maintenance of the ecological functionalities of the impacted territory with regard to the protected species concerned (natural evolution of populations and respect for connectivity between them).

The acceptance of the derogation takes place after investigation by the State departments, within the framework of the environmental authorisation and after the opinion of the Conseil Scientifique régional du patrimoine naturel³, an organisation composed of scientific and technical experts.

Even if this procedure is initiated only after the Déclaration d'utilité publique, the issues related to the protection of species must be identified and taken into account as early as possible, especially when there are different preliminary files, so as to correctly size the measures. In some cases, the project promoter may even request an initial opinion from the CNPN or CSRPN as an indication on the basis of a file of principle.

³ The opinions to be produced between the CNPN and the CSRPN Conseil Scientifique régional du patrimoine naturel are broken down according to the importance of the species concerned (decree of 6 January 2020 setting the list of animal and plant species whose protection may only be derogated after consulting the Conseil National de la protection de la nature).

Otherwise, upgrading protective measures can be much more complex and cause delays in planned schedules.

Natura 2000*

According to Article L.414-4 of the French Environmental Code*, works, structure or development programmes and projects subject to an authorisation or administrative approval scheme and likely to significantly affect a Natura 2000* site, individually or through their cumulative effects, must be assessed for their impact with regard to the site's conservation objectives.

The content of the impact assessment file is set by Article R.214-36 of the French Environmental Code.

Like the protected species derogation file, the project promoter must justify the absence of other satisfactory solutions.

This assessment is intended to prevent impacts on the conservation objectives of Natura 2000 sites. The assessment must make it possible to determine and quantify the impacts of a project on the conservation objectives of all the natural habitats and species that led to the designation of the site and to present the measures envisaged to avoid significant effects of the project.

Where, despite the measures envisaged, significant adverse effects remain on the conservation status of natural habitats or species, the file must set out the reasons why there is no satisfactory alternative, the imperative reasons of public interest justifying the project and the offsetting measures planned to ensure the overall coherence of the Natura 2000 network and their cost. However, these offsetting measures must remain exceptional. They lead to the information of the European Commission, or even a request for an opinion in some cases.

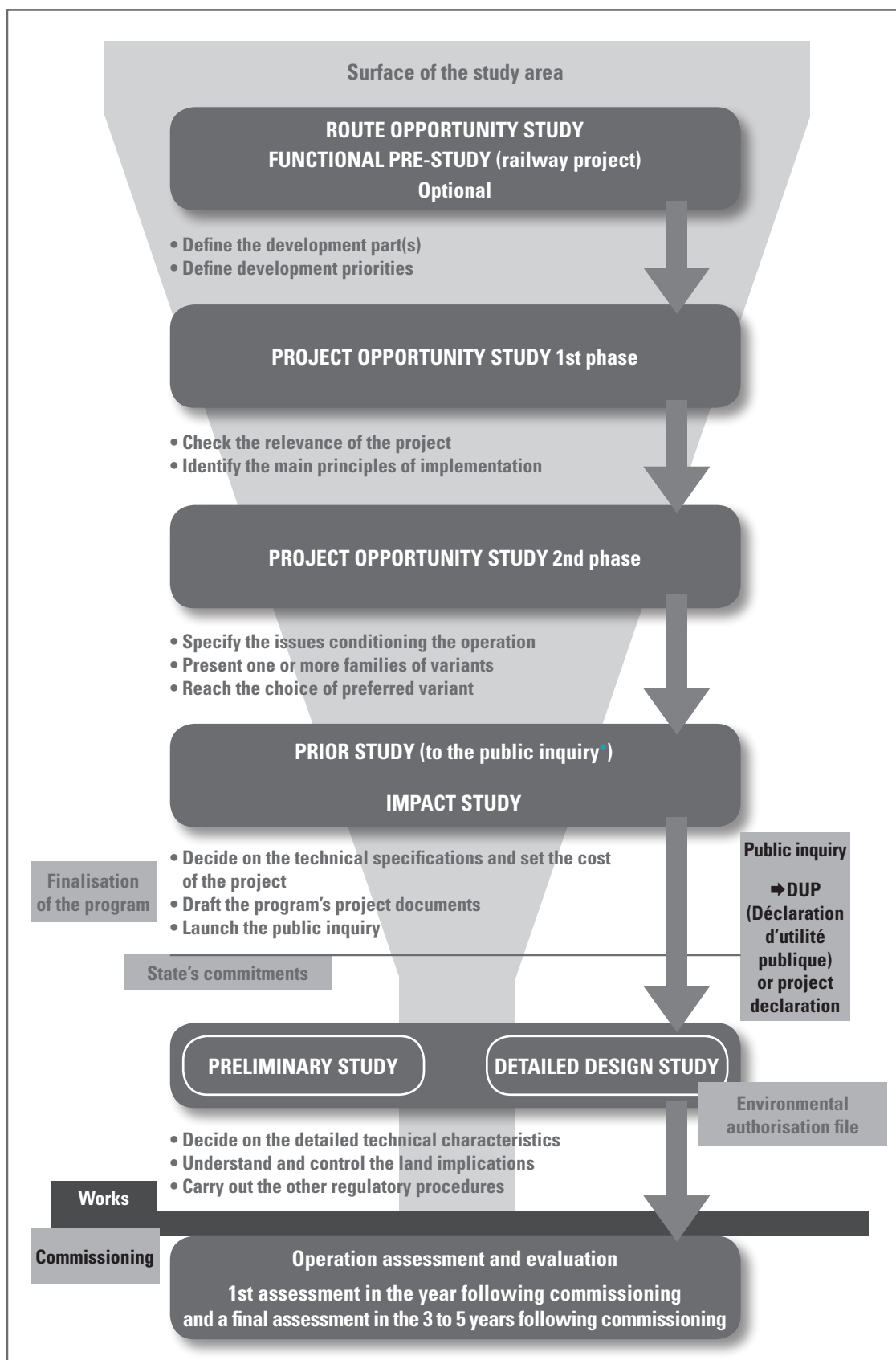

Diagram of the different phases of studies, consultation and implementation of a road project on the national network.
Source: Ministry of Ecological and Solidarity Transition, 2018

Ensure good social acceptance of fauna passages

Fauna passages are expensive structures and for some, strongly identifiable in the landscape.

Studies and feedback show that acceptance by local stakeholders of the presence of a fauna passage and understanding of its role and legitimacy are among the project's success criteria.

Acceptance or non-acceptance can be expressed in several ways and concern either the general public or specialised stakeholders.

Cost of the infrastructure

The structure may appear illegitimate for part of the general public if its cost seems disproportionate to the issues. On the one hand, fauna passages are expensive and on the other hand, the public is still poorly informed about the impact of infrastructure on biodiversity*, the consequences for ecosystems and *ultimately* for humans. This can result in a misunderstanding or even a rejection of the structure, considered as an unnecessary and even extravagant expense. This rejection often results in a comparison with spending showing positive effects that are more easily perceptible by the population (social welfare, etc.).

Information provided very early on in the process, to a very wide audience, can help defuse this mechanism. The comparison of the cost of the passage with the cost of the infrastructure whose impact it must reduce is also likely to bring things back to their proper proportion. It is also necessary to remember that biodiversity* is only one area among many other environmental issues that concern humans more directly (noise, water, etc.) and for which substantial investments are allocated.

Potential conflicts of use

Conflicts of use may concern foresters, farmers, walkers, mountain bikers, people practising various sports or hunters. In other words, everyone who can perceive a human use of the passage.

This use can be fully assumed in the case of mixed passages that integrate from the outset a use for the crossing by agricultural or logging machinery or walkers. These are situations where human use is deemed compatible with ecological functionality.

However if local stakeholders have not understood the ecological function of the passage, it may be damaged by unsuitable uses. Here are some real-life examples:

- use by loggers of the large space of an eco-bridge* as a wood storage area that reduces the attractiveness of the fauna passage;
- positioning by the tenant of the local hunt of a watchtower in the extension of an eco-bridge that limits the use of the passage by large fauna.

Communication that is both broad and targeted on the target audience must at least partly avoid these difficulties. This communication can take different forms:

- in the case of a new project, the contracting authority usually has the opportunity to be in contact with the relevant stakeholders. Ecological permeability must be integrated into their presentation;
- in the case of the creation of a passage over or under an existing road, specific communication procedures must be undertaken: publications in local newspapers or communal gazettes, public meetings, or even field visits, etc.

A special approach must be taken towards local stakeholders, potential users of the passage. It is possible to go further, by associating certain structures with the design of the replanting of the passage, or even by entrusting them with maintenance or monitoring by signing an agreement. A charter can then be defined and signed between the parties (prefecture, concession company, riparian owners, walkers, hunters, managers of the structure, etc.) designating the roles of each in the life of the structure.

For example, the A16RIF eco-bridge on the Sanef network has been the subject of a stakeholder commitment charter and a management and monitoring agreement with the Fédération inter-départementale des chasseurs d'Île-de-France (hunters' federation) to settle the subject of conflicts of use.

In some cases, an approach targeting local school children may be appropriate. In this regard, we can mention the approach taken by Vinci Autoroutes with the participation, as part of a school site, of an agricultural high school in the Landes département in the creation of a large sealed pond, on the Peyreharasse eco-bridge* of the A64 motorway and the visit of a school to the same site in 2017, in partnership with the CPIE Seignanx Adour and the Landes hunting federation.

Finally, local nature conservation groups deserve to be involved in these efforts, as they can greatly facilitate local acceptance.



Participation of a school in the plantations carried out on the eco-bridge of the A10 motorway of La Lande forest. Source: Vinci Autoroutes/ASF network.





PART TWO

1. Fauna passages on new infrastructure projects

1.1. All fauna passages

FACT SHEETS

- 5 Where to build an all fauna passage*?
- 6 What type of all fauna passage should be chosen?
- 7 How to size the passage?
- 8 How to design and develop all fauna passages?
- 9 What are the different types of construction? At what cost?

1.2. Passages and developments for small fauna

FACT SHEETS

- 10 Where to build small fauna passages?
- 11 How to develop small waterway structures for small fauna?
- 12 How to develop agricultural/forest/pedestrian structures for small fauna?
- 13 How to develop specialised structures (amphibian passages - tree canopy passages)?
- 14 How to develop common small fauna passages?

FAUNA PASSAGES: AN EFFECTIVE MEASURE TO RE-ESTABLISH TRANSVERSAL CONNECTIVITIES

2. On existing infrastructure – Upgrading

2.1. Development of existing structures

FACT SHEETS

- 15 How to improve the functionality of existing fauna passages?
- 16 How to promote the passage of small fauna on existing structures not dedicated to fauna?

2.2. Construction of new structures

FACT SHEETS

- 17 Where and how to build an all fauna passage on existing infrastructure?
- 18 How to create a small fauna passage* on existing infrastructure?

2.3. Other developments

FACT SHEETS

- 19 What are the warning systems (fauna and/or vehicles) set up to reduce wildlife vehicle collisions?

1 Fauna passages on new infrastructure projects

The aim of developing a fauna passage is to reduce the impact on ecological corridors by restoring some of the connectivities that may be interrupted by a new infrastructure.

Fauna passages thus make it possible to:

- limit the fragmentation of animal habitats and populations;
- contribute to maintaining ecological processes and the functioning of the metapopulation*, by ensuring opportunities for genetic exchange and mixing between populations (dispersal of young or adults to other territories, emigration of individuals);
- re-establish daily movements within the species' home range by maintaining, for example, access to certain resources (e.g.: feeding, reproduction area, etc.).
- maintain movement opportunities for migrating species* (e.g. seasonal);
- ensure safe crossing of the infrastructure by fauna, when associated with a restraint and guiding system adapted to the fauna in question (fencing, barriers, screens, etc.);
- reduce traffic accidents.

While fauna passages make it possible at a given point to restore certain connectivities, not all species use the structure spontaneously. Depending on the species, some adaptation time is required to integrate the structure into their habitat and habits. This time is both needed by the animals to locate the structures and to feel safe enough to use them. It also takes time to ensure that ecological coverage (planted vegetation) reaches a sufficiently functional stage (dense cover by hedgerows or tree crowns*, etc.). The monitoring of the fauna passage (in particular meeting the obligation of results of the measure) makes it possible to verify its use.

However, even in the long term, fauna passages do not make it possible to compensate for all the exchanges lost along the infrastructure, particularly for species with low mobility capacities.

Logically, the optimisation of this transparency requires an increase in the number of structures, in particular very wide passages. However, these structures represent a significant financial cost which prevents their increased construction (see Chapter 3.4. Guaranteeing social acceptance). **The search for the best compromise between ecological constraints (increasing connectivity to the maximum) and economic constraints (proportional to the number and size of passages) is therefore an essential criterion.**

The search for this compromise is based on the prior prioritisation of issues and the ability to respond appropriately to these issues through the use of different structure categories.

Beyond the financial aspect, the arguments justifying the installation of a structure and its dimensions must include data related to habitats and species as well as the functions that the development must perform for the fauna.

Generally speaking, there are two major categories of passage:

- **large or "ALL FAUNA" structures reserved for the highest issues. They generally allow the passage of a maximum of species of large and small fauna;**
- **"SMALL FAUNA" passages that provide a minimum level of transparency for small animals throughout the infrastructure.**



In the context of a new infrastructure project, the restoration of ecological transparency through the construction of fauna structures follows a certain logic characterised by two major stages:

1 The first stage generally aims to define and localise large structures (ensuring the passage of large and small fauna) according to the main issues identified: location, size, characteristics, etc.

2 It is only once the most important structures have been positioned that the contracting authority will complete its project by looking for secondary structures to restore the passage of small animals:

- starting with developing all waterway structures (a) so that they are easy to cross;
- supplementing with dedicated passages (b) to meet the issues of small fauna (e.g. amphibians, small protected species, etc.);
- adding additional crossing opportunities through the development of structures for other uses (c), or building additional small fauna passages (d). The final objective is to have, on average, a passage possibility every 300m adapted to small fauna.

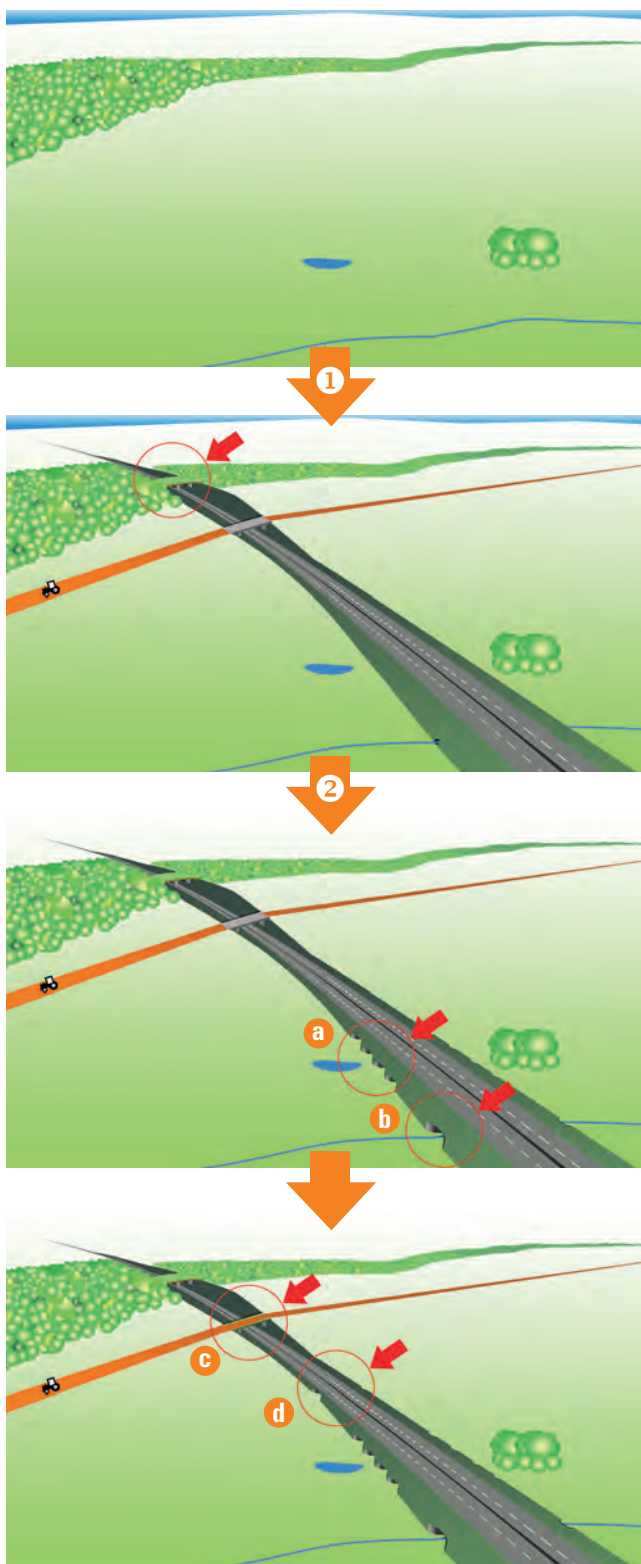

FACT SHEETS 5 TO 10

FACT SHEETS 11 AND 12

FACT SHEETS 13 AND 14

Source: Cerema.

1.1 All fauna passages

With some exceptions, all fauna passages (20 metres wide and more) are reserved for large infrastructure such as railway tracks or wide road infrastructure (dual carriageways and larger) which are usually associated with physical barriers (barrier fencing, etc.) preventing fauna from crossing the infrastructure.

Choosing the location of a fauna passage and its characteristics is complex. Even if recommendations or best practices can be published, it is difficult to define excessively precise regulatory standards on the number and exact location of fauna passages on

these infrastructures, because they depend on the ecological value of the environments crossed, the regulatory obligations (SRCE/SRADET, protected species), the technical feasibility, acceptance by all relevant stakeholders and the cost of the structures.

The objective is to ensure the feasibility, efficacy and economic acceptability of these measures.

The efficacy⁴ of a passage depends on its position in the landscape, the type of structure, its characteristics and its layout (including surrounding areas).



Source: © VINCI Autoroutes photograph library – Emmanuel Rondeau.

⁴ Efficacy remains a difficult concept to measure. While it often refers to the use of the structure by the species (number of visits), it tends to be used to highlight a vital function of the species or the maintenance of its population (its functionality).



A6 motorway: one the very first passages in the world built for fauna

In 1954, the French Minister of Public Works announced the launch of a first national motorway construction program. The Conseil général des ponts-et-chaussées was tasked with proposing a project for a priority infrastructure network project. The State officially retained the principle of a continuous motorway between Paris, Lyon and Marseille. Mainly built in the 1960s and 1970s, the A6 motorway linking Paris to Lyon is one of the first French connecting motorways.

During the design of the project, however, some sections produced resistance and difficulties, particularly for crossing the Fontainebleau forest, because many opponents wanted it to be bypassed. However, after more than ten years of battles, the solutions and arbitrations finally maintained the crossing of this forest.

In return, special attention was paid to the valleys of the Cavachelins and the Vallée Chaude (part of Noisy-sur-École), as they constituted two essential routes between the east and west of the forest. These valleys are not crossed by high embankments, but by two viaducts with a total length of 200 metres, to allow exchanges on both sides of the motorway, both for walkers and for animals.

Built between 1960 and 1962, these structures were the first two European fauna passages and among the very first fauna passages in the world, after those built in Florida for bears in 1955. The A6 motorway and these two viaducts are currently operated by APRR.



*A6 motorway crossing the Fontainebleau forest in 1963.
Source: National archives, WikiSara.*



*Vallée Chaude before the construction of the infrastructure
Source: National archives (scale 19771464/41), WikiSara.*



Cavachelins viaduct. Source: Vincent Vignon/OGE.



Vallée Chaude viaduct. Source: Vincent Vignon/OGE.

During the 1960s, the construction of the A6 motorway caused deer to emigrate east of the project to the Essonne. In 2015, a genetic study carried out on deer around Paris showed significant genetic differentiation on both sides of the A6, but secondarily in the structuring of populations observed in the Greater Paris area. This disruption was probably mitigated by the use of viaducts (Vignon & Suez, 2017).

FACT SHEET

5

Where to build an all fauna passage*?

As a priority, on high-issue ecological networks

There are three main preliminary steps:

1 Identification of interrupted ecological networks

An all fauna passage is first and foremost recommended when the infrastructure interrupts the ecological network of great interest or because it cuts off corridors of several or specific species (heritage, of major hunting* value).

An infrastructure project must firstly address and maintain the ecological network identified in the SRCE/SRADET.

While the regional green and blue grid* provides information on the presence of the ecological network, it is only identified in the SRCE at a scale of 1/100,000, which does not allow precise differentiation of the networks to be maintained in light of a project. In the context of a new project, these maps of the area crossed need to be specified on a finer scale, from 1/25,000 to 1/5,000, in order to account for the landscape structures playing a role in the movement of the species (note, the local diagnosis on networks can in no case be considered as a zoom of the maps of the SRCE/SRADET).

On the other hand, the absence of a regionally recognised corridor in the SRCE does not necessarily mean that there are no more local issues. More diffuse ecological networks, unidentified in regional work or in a **smaller area and not perceptible at the SRCE/SRADET level, may be present and must be integrated into the project.**

When they are not known or are insufficiently localised, the difficulty then lies in the precise identification of these networks.

Major functional ecological networks in a given area are usually identified and materialised:

- either by a species-based approach. For all fauna passages, the main focus is on heritage, hunting*, keystone, umbrella species (demanding species whose protection allows the preservation of less demanding species) or even on certain species series (species with the same life traits). This involves identifying the living environments of the species (feeding, breeding, resting) and the elements (adjacent or not) supporting the movements of the targeted species or series;
- or through an environment-based approach (forests, bocage areas, open environments, etc.) which helps to simplify the analysis. The objective is to identify all the favourable landscape elements or structures necessary for the functioning of the ecosystems crossed (see fact sheet 2).

In all cases, these approaches must also take into account existing knowledge on the area and in particular protected areas (e.g. Natura 2000* site, nature reserves, etc.) or warning perimeters (ZNIEFF, etc.). These areas provide information to analyse the prioritisation of networks..

2 Identification of networks requiring restoration by an all fauna passage

The insertion of a fauna passage into the landscape will condition much of its efficacy. It is therefore logical to position passages on the main ecological networks identified and interrupted by the infrastructure, if optimum efficacy is sought. However, there may be a large number of networks crossed and it is not always possible to restore them in their entirety.



An average possibility of an all fauna passage every **2km** is recommended (1-3km in well-preserved habitats, 3-5km in deteriorated habitats).

The networks to benefit from a structure are then chosen according to the value of each one, their distribution in the landscape and existing constraints. Nor is it a question of excluding a higher frequency of passages if the issues warrant it.

It is possible to distinguish a few major situation categories:

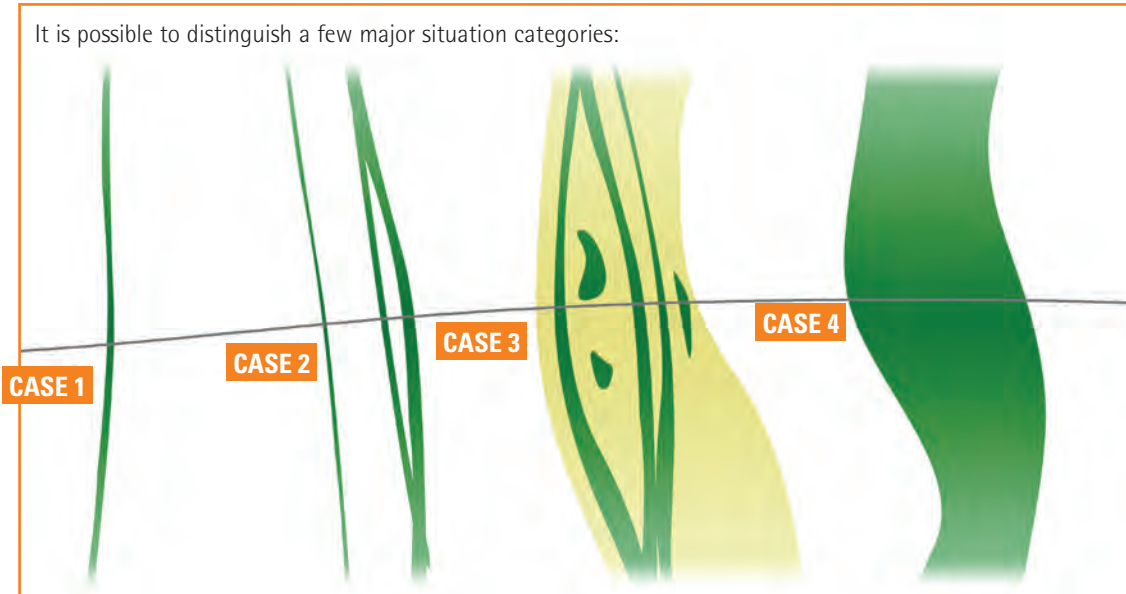

1 Schematic representation of ecological network categories. Source: Cerema.

CASE 1

The networks are very localised, differentiable and relatively spaced out. This is usually the case of highly contrasting environments such as a wooded strip within a farmed area. The structure proposed must of course be in line with this continuity.



Example of a localised ecological network. Source: Google Earth.

Zoom in on the location of the fauna structure. Source: Google Earth.

CASE 2

Ecological networks also easy to identify, but relatively close to each other. Priority will then be given to re-establishing the corridors of greatest interest by possibly supplementing them with other structures, in order to ensure sufficient overall permeability.

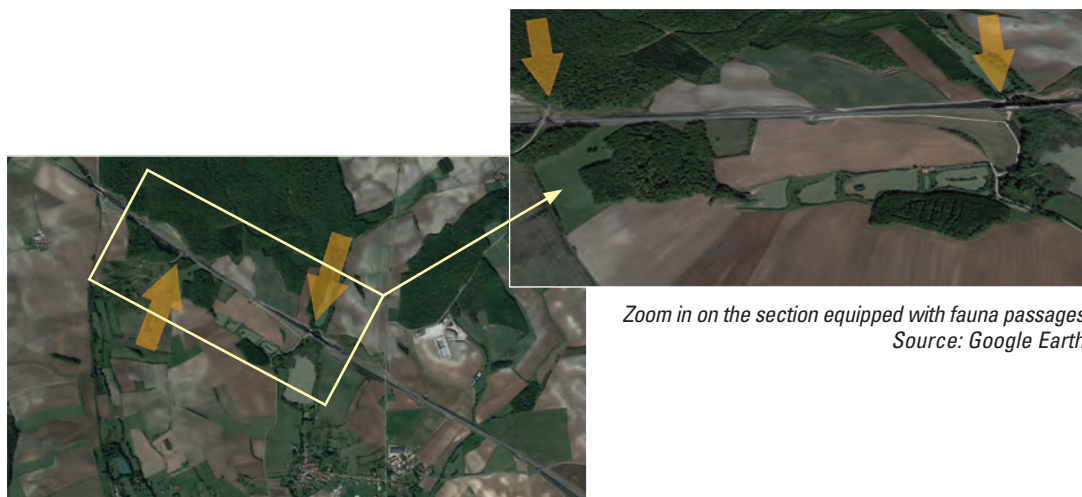

*Zoom in on the section equipped with fauna passages.
Source: Google Earth.*

*Examples of similar ecological networks.
Source: Google Earth.*

CASE 3

These are large corridors, especially when the infrastructure passes through rich and diverse areas that form a mosaic of environments.

It will then be necessary to identify any secondary landscape structures that best support the movement of species, in particular target species. Under these conditions, however, the regular distribution of the structures will be easier and often guided by local technical constraints.

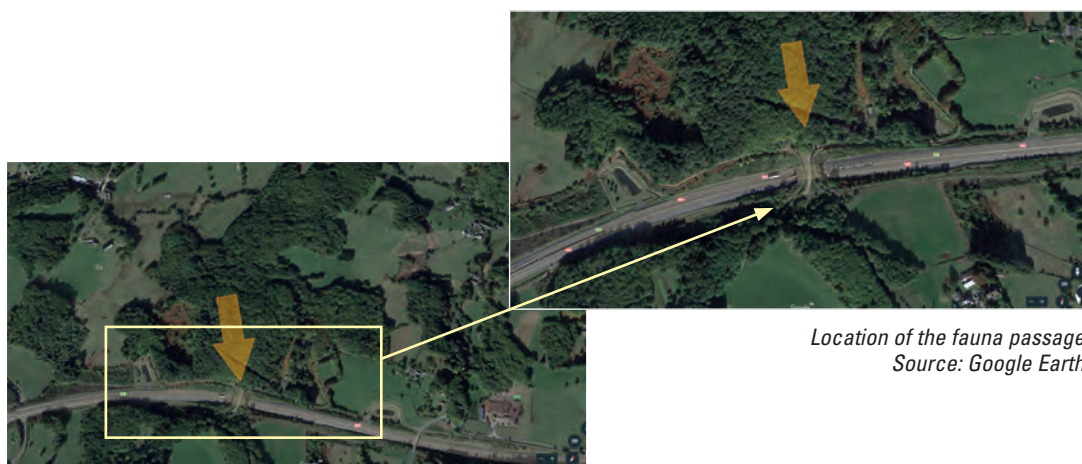

*Location of the fauna passage.
Source: Google Earth.*

*Example of vast ecological networks in a rich and diverse area.
Source: Google Earth.*

CASE 4

It is a vast homogeneous environment which in itself constitutes a network of interest. The restoration conditions will in this case be essentially guided by the secondary components of the relevant grid and by the technical characteristics of the project (lengthwise profile, etc.) (see ③ below).

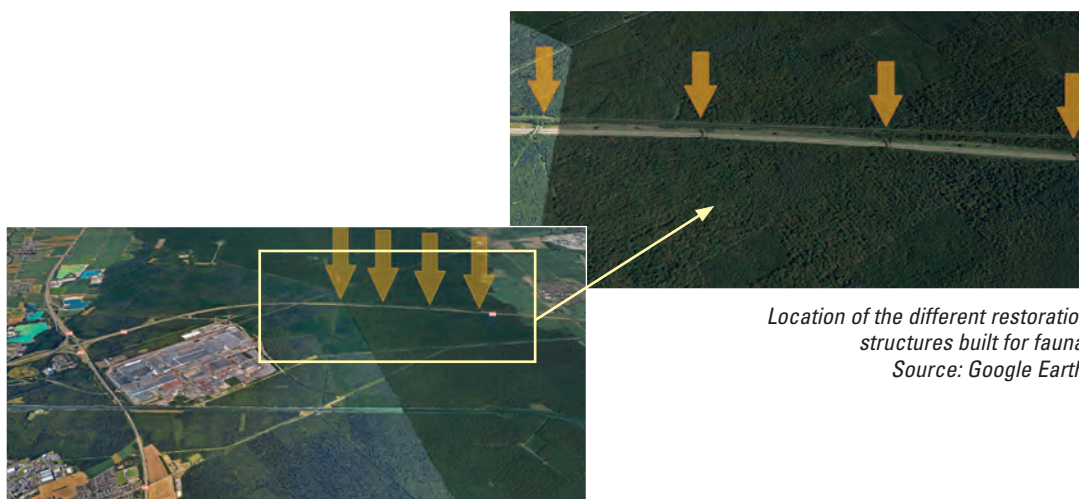

*Location of the different restoration structures built for fauna.
 Source: Google Earth.*

*Ecological network consisting of a vast homogeneous environment.
 Source: Google Earth.*

③ Taking secondary issues into account to specify the optimal position of structures

Continuities can sometimes prove to be quite broad and offer several location possibilities within the very continuity to be restored. In this case, besides taking into account the technical constraints, the precise localisation will strive to position the structure with regard to more local interests (②) such as the presence of a talweg, the quality of the environment, the existence of a protected area, etc.

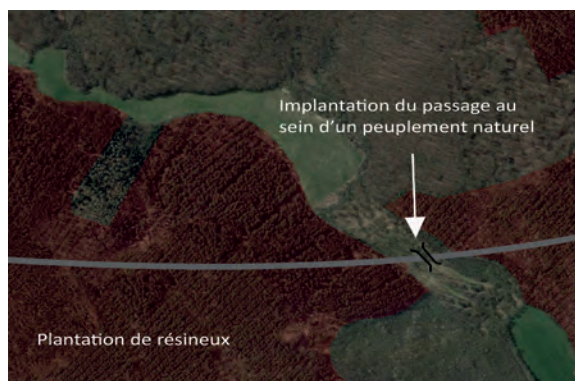

② Fictitious example taking into account secondary issues within a vast ecological network. Source: Geoportail.

In ordinary habitats to provide sufficient overall permeability

Landscape ecology has shown that an approach essentially based on the protection of high-issue habitats is not enough to preserve and restore biological diversity, because all the systems that make up the landscape fabric are connected and evolve. The concept of the green and blue grid* is based on this principle. It consists in preserving or restoring the ecological network throughout the territory, in order to maintain a coherent ecological operation.

The notion of overall transparency of the infrastructure must also be considered from this angle.

Therefore, even if the analysis of the territory does not seem to justify the construction of a fauna passage with regard to local issues (absence of strong and localised ecological issues), a large structure must nevertheless be considered in certain situations.

This is the case when biodiversity issues* are low and/or diffuse in the territory and:

- there is no possibility of creating a fauna crossing (even for small fauna) for more than three kilometres. This is sometimes the case, when the characteristics of the infrastructure (e.g. excavated section) do not allow it or make it difficult to locate small fauna passages. An all fauna passage (called "additional") must then be built on the relevant section;

- the infrastructure has opportunities for small fauna passages but no all fauna passages for more than 5 kilometres (③).

In this case, in order to comply with the above minimum intervals, it is recommended:

- either to provide an all fauna gauge (15m wide at least) for an agricultural-type restoration structure when it is planned for the structure;
- or in the total absence of a structure, to install a dedicated additional structure (7m wide: see sheet no. 7 "How to size the passage?").

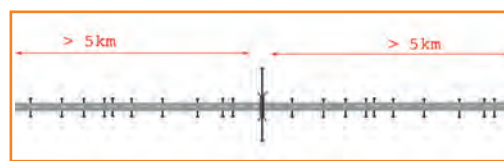

③ Schematic representation of the location of an all fauna passage on a section of infrastructure equipped with small fauna passages and not presenting a major issue.

These provisions are essential to make the infrastructure more resilient, especially to climate change, to preserve the future and thus ensure that it may be crossed by species that are not yet present.

These provisions can therefore lead to the creation of all fauna passages in more ordinary but equally strategic environments to preserve the ecological network in the medium and long term (④).



④ Example of the Munt structure – Belgium.



Sources: photograph 1: Google Earth, photograph 2: Omgeving.

Localisation taking into account technical constraints and other restoration structures

Taking into account technical constraints

While the priority lies with taking into account issues during the localisation process, the choice of the location of a structure in the extension of the initially identified networks is not always advisable, as it is technically difficult, too expensive or ultimately not very effective for the fauna.

■ Taking into account the profile along the length and topography of the land

The construction of a structure is facilitated on sections with a lengthwise profile with sufficient and homogeneous excavated material or backfill on each side of the infrastructure, as the design is usually simpler and less expensive. Unfortunately, when the programming of a structure is not integrated early enough into the design process or when the characteristics of the project simply do not allow it, the lengthwise profile and the local topography are not always favourable on the ecological network to be restored.

Low-lying profiles (at the natural ground level), an overhanging view of the motorway or a pronounced mixed profile (cut and fill) (5) thus offer complex situations that increase the deterrent effect of the passage or make the construction of a structure more difficult economically.



5 Schematic example of a pronounced mixed profile where the insertion of a structure is complex. Source: Cerema.

In case of difficulties, the structure may, **on justification**, be slightly shifted (< 500m) from the initial ecological network, in order to find more suitable profiles. However, these solutions depend on the issues at stake. Also, when the latter are high, the choice of a technically more complicated and expensive structure may be justified.

The shift of a structure away from continuities also requires additional adjustments essential so that the structure remains ecologically closely connected to the interrupted corridor.

The aim is to reserve and develop a corridor along the infrastructure through to the structure (7 and 9 next page).

For a **0 to 250m** shift, we recommend a length **at least equal to the width of the structure**. This value may, however, be reviewed and clarified according to specific studies on the behaviour of potentially present series or proven species likely to use the structure.

Example: for a corridor of local interest with movement of deer, for which it is necessary to carry out a mixed structure of 30m (see sheet no. 7 "How to size the passage?"), the width of the lateral reconnecting corridor shall be at least that width.

Similarly, in the absence of specific studies, for a **250 to 500m** shift, the width of the lateral reconnection corridor must be equal to **at least twice the width of the structure**.

This corridor must necessarily consist of favourable habitats equivalent to the environments constituting the interrupted continuity. Slopes can only be considered as an integral part of this ecological network if the habitats that are reconstituted there are favourable and easy to access (no fencing, low incline, etc.).

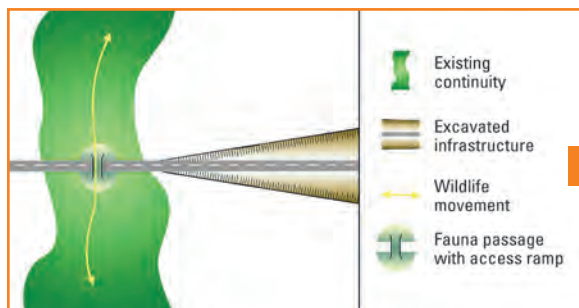

6 Infrastructure at the natural ground level requiring the development of a structure with an access ramp for fauna. Source: Cerema.

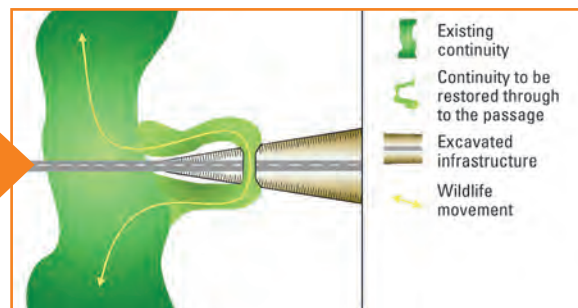

7 Shift of the structure to an excavated section facilitating the development of a passage. Source: Cerema.

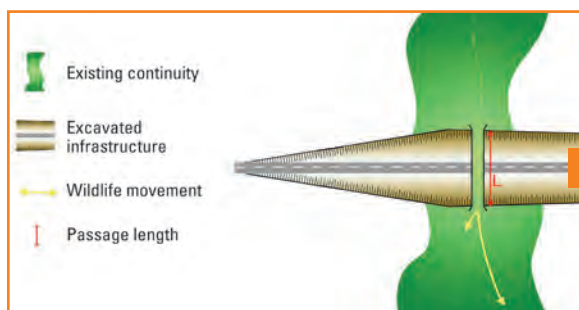

8 Infrastructure in heavy excavation leading to a long crossing on the passage. Source: Cerema.

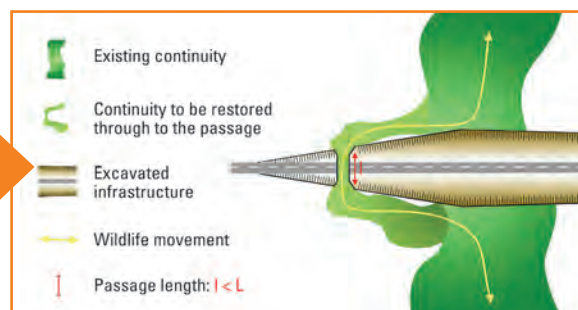

9 Shift of the structure to a section with less excavation facilitating the development of a passage. Source: Cerema.

In addition, to make these additional developments sustainable, the land should be secured and a sustainable and adapted maintenance policy established (purchase, management agreement, etc.).

Physical constraints on both sides of the infrastructure

In order to ensure the functionality of the structures, it is essential to ensure the absence of existing or future constraints (e.g. development of activities) likely to disrupt or prevent the effect of the transparency to be restored. To put it simply, a structure must not lead to one or the other of these constraints and must be positioned in an environment that remains favourable to wildlife beyond the infrastructure coverage. Consultation of local planning documents is an essential prerequisite.

These constraints may be:

- **natural:** presence of cliffs, a wide watercourse parallel to the infrastructure, etc.;
- **human:** presence of a built area, a canal, a road (10), a railway track, etc.

Beyond existing constraints, it will also be necessary to take into account future projects of which one may be aware or which are very likely (e.g. building areas, other infrastructure, etc.). The construction of a structure leading to an obstacle* requires addressing both the passability of the infrastructure and of the obstacle. This case will be all the more important to address the shorter the distance between the infrastructure and the second obstacle is and if the spaces between the latter two are too small to constitute natural stopping point habitats for the target species.

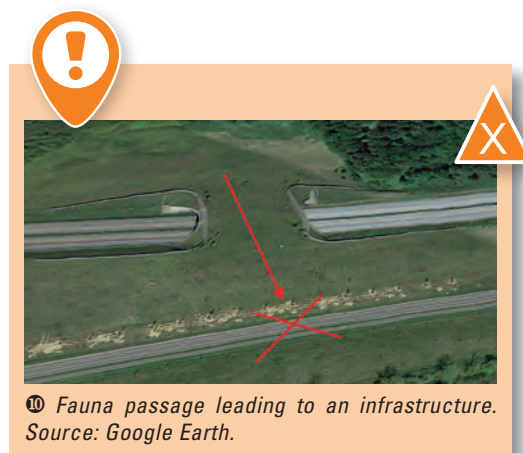

10 Fauna passage leading to an infrastructure. Source: Google Earth.

Seeking complementarity with the restoration of other uses (agricultural/forest/pedestrian path)

Fauna passages can have a related function. They can be built in conjunction with a waterway, agricultural, forest, or even pedestrian restoration, for economic reasons. This search for diversity often determines the localisation of structures.

If for a forest or waterway restoration, the question does not really arise, because they generally come together within the same ecological networks, agricultural restorations are not intuitively located on them.

For these structures, where possible and when the increase in the agricultural traffic is reasonable, priority will be given to the initial ecological network and agricultural passages will be built in line with the corridors (11).

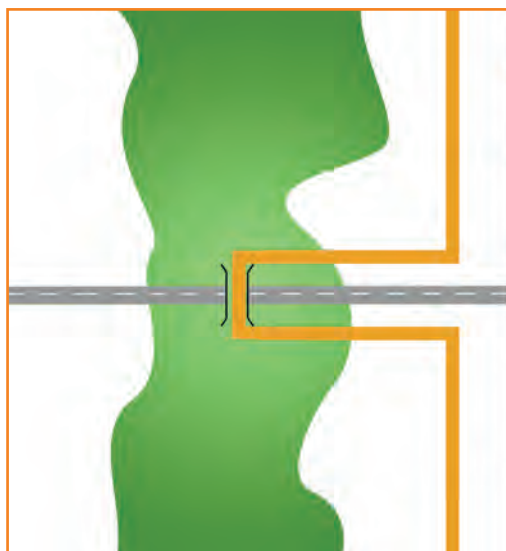

11 Relocation of the agricultural restoration on an ecological network. Source: Cerema.

If this is not possible and if the decision is taken to shift the structure with respect to the landscape network supporting the ecological issues of movement, the structure must be accompanied

by specific measures to reconnect the separate structures to the passage (creation of a corridor along the infrastructure) (12 and 13).

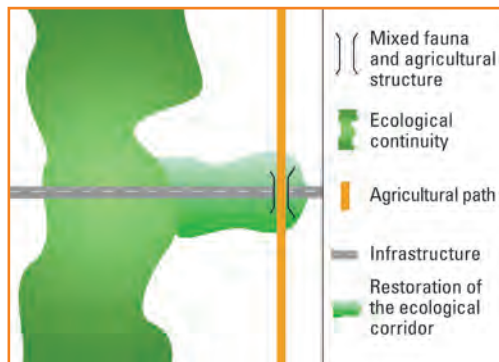

12 Schematic representation of a structure shifted from the ecological network and requiring the restoration of a natural corridor to the structure. Source: Cerema.

Like the shifting of a structure for technical reasons (lengthwise profile), the width of the lateral reconnecting corridor must, in the absence of specific studies, be equal to:

- the width of the structure (see previous page) when the corridor and the structure are 0 to 250m apart;
- twice the width of the structure when they are 250 to 500m apart.

It should also be borne in mind that the efficacy of a fauna passage is often limited when the passage is of moderate size and is also used by humans.

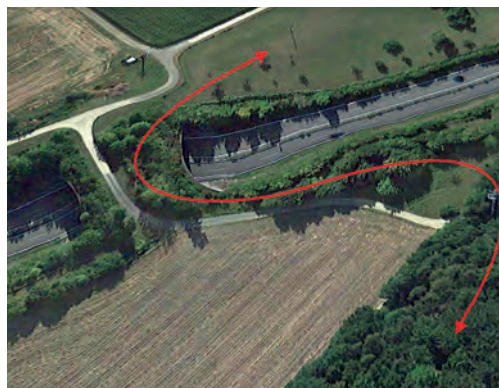

13 Structure shifted from the forest, but which remains connected to the forest continuity. Source: Google Earth.

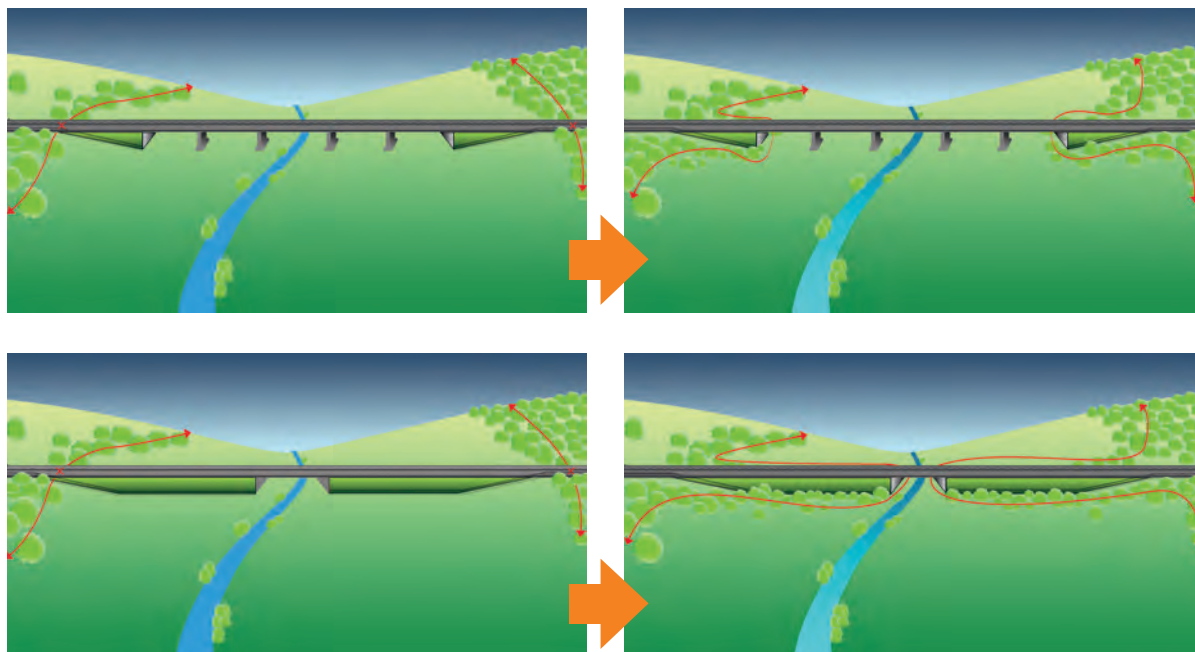

14 In steep sided valleys, the often wooded hillsides require measures to reconnect these wooded strips to the waterway crossing structures. Source: Cerema.

Waterways and their riverine vegetation* are privileged corridors. The usage of waterway structures with a fauna passage is often self-evident. In some cases, however, the hillsides of talwegs are in themselves forested continuities parallel to, but remote from, the watercourse. Since the construction of several structures on each corridor is often difficult to justify, a single larger structure on the waterway continuity is recommended, while nevertheless ensuring the connection with the wooded corridors located on the hillsides (14).

Positioning based on other nearby fauna passages

This is particularly relevant when:

- the project is twinned with another infrastructure which already has a restoration structure. In this case, and if the structure of the first infrastructure is functional, a restoration structure is necessarily aligned with (or positioned as close as possible to) the existing structure. It is then desirable for the new structure to have characteristics at least as favourable to wildlife circulation as the pre-existing passage (15 and 16);

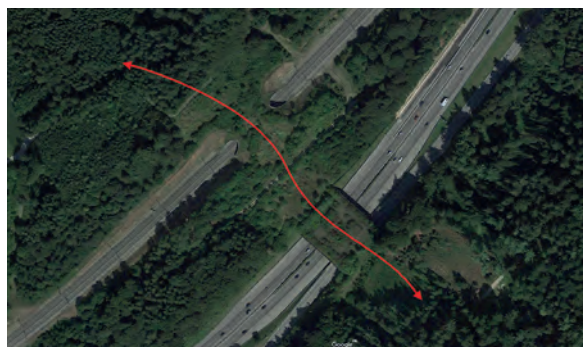

15 Twinned infrastructure on each of which a structure of equivalent size has been built. Source: Google Earth.



16 Twinned infrastructure where the fauna passages of the road infrastructure are located in continuity with the railway tunnel. Source: Google Earth.

- at road interchanges, entry and exit slip lanes are a second barrier that need to be factored in. Structures must therefore be planned on both infrastructure sections (17).

To improve the efficacy of passages, the two sections must be linked by a favourable guiding structure (plantations), in line with the environment of the corridor to be restored.

However, the search for an installation further upstream of the interchange must be studied in priority.

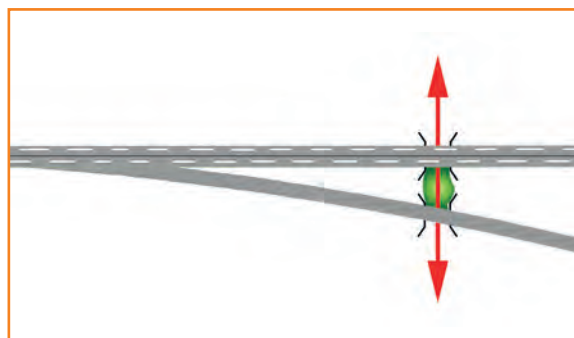

17 Schematic representation of the maintenance of the ecological network on an interchange by building two successive structures and installing an ecological strip between the two structures. Source: Cerema.



Where to build an all fauna passage?

As a priority, on high-issue ecological networks

In ordinary habitats to provide sufficient overall permeability

Construction of a fauna passage if:

- Absence of any possibility of crossing (even for small fauna) for more than 3km.
- Presence of crossing possibilities for small fauna , but absence of all fauna passages for more than 5km.

Localisation taking into account technical constraints and other restoration structures

- Shift in the position of an all fauna passage due to strong technical constraints (inappropriate lengthwise profile, obstacle, etc.).
- Need to ensure complementarity with other uses (possible if faunistic issues are not too important) by prioritising the displacement of other usages on the continuity.
- Need to ensure continuity with other transparencies (twinning of infrastructure).

**On average, one fauna passage every 2km
(1-3km in well-preserved habitats, 3-5km in deteriorated habitats).**

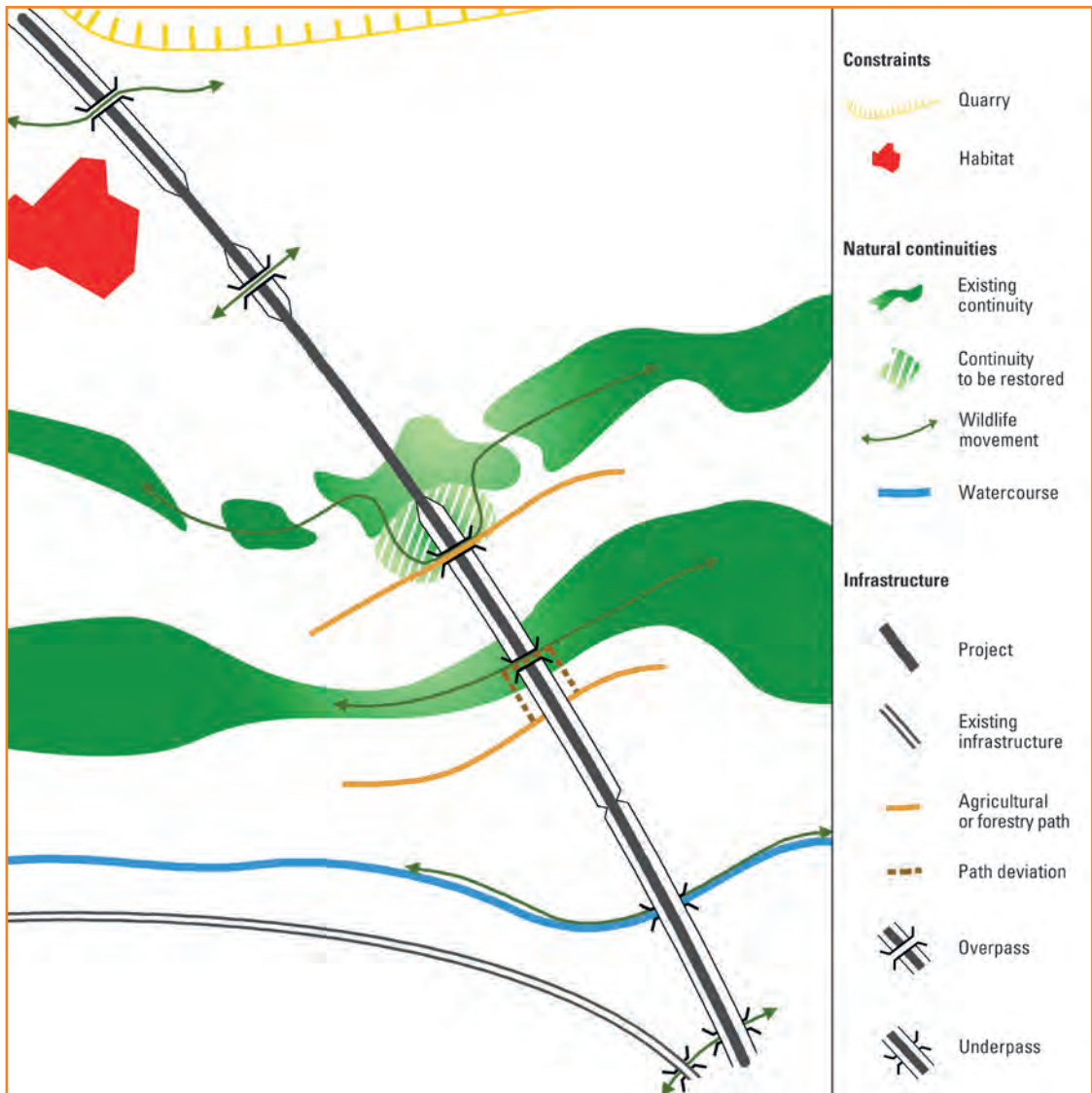

Summary diagram of the location of all fauna structures in relation to the physical and natural environment. Source: Cerema.

FACT SHEET

6

What type of all fauna passage should be chosen?

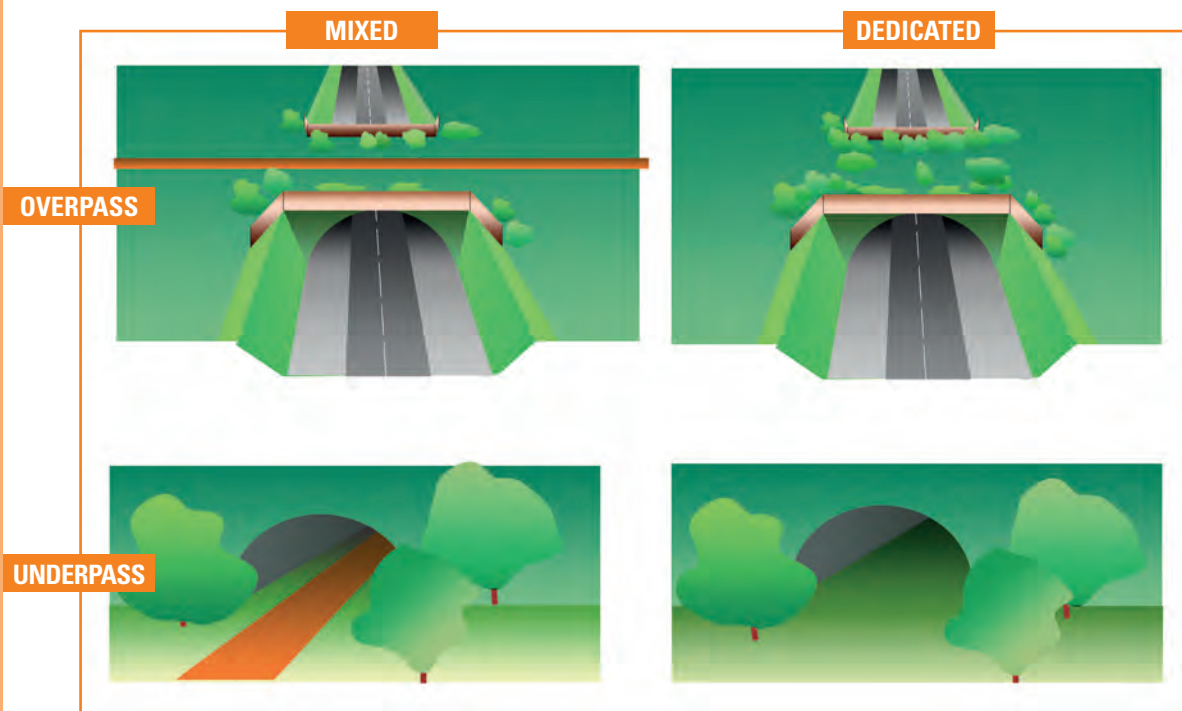

The 4 main categories of structures. Source: Cerema.

Overpass or underpass: a choice defined according to the lengthwise profile

Two categories of passages can be distinguished: overpasses and underpasses.

The passages are called "overpasses" when the animals cross above the infrastructure. Conversely, when the animals pass under the infrastructure, the passage is called an "underpass".

The type of passage is firstly chosen according to the lengthwise profile of the infrastructure. Although this profile can sometimes be conditioned by ecological interests, this approach remains rare and, even if, during the design phases, its

implementation can lead to some profile adjustments, it is most often the profile that defines the choice of the type of passage. This is almost always an overpass on excavated or slightly backfilled sections and an underpass on the sections with major embankments.

For smaller structures, if the development of the project makes it possible, however, to make a prior choice and, if it is technically and economically possible to construct an overpass, this solution will be chosen provided that the techniques used do indeed make it possible to plant and optimally grow the desired vegetation.

While the efficacy criterion in the choice of an overpass or an underpass, when small in size, is rarely taken into account, for structures of equal size, the success of underpasses appears more difficult to achieve, in particular because of elements likely to exert more deterrent effects:

- absence of light;
- little or no vegetation;
- difference in temperature compared to the outside environment.

However, underpasses remain interesting when they are correctly positioned, sized and developed for fauna.

In some cases, underpasses may be more advantageous, particularly in the case of high-rise structures (viaducts). The latter have the advantage, by virtue of their height and their short crossing length, of enabling the initial areas present under the structure to be maintained or reconstituted.

All fauna overpasses or eco-friendly bridges*

This category of passages has the main advantage of allowing vegetation of the deck as well as the passage of thermophilic species.

While, in general, overpasses are designed on excavated sections, several situations can be differentiated:

■ When the height of the excavation is at least equivalent to the height of the structure

This configuration is ideal because these passages most often provide easy access for fauna and visual continuity with the environments located on either side of the structure (❶).

■ When the infrastructure is at the natural ground level (possibly in a slight embankment)

An overpass is possible, but it requires:

- either the construction of an access ramp to the passage entrance (❷ and ❸ next page) which must maintain a moderate slope so that it may be easily accessible to fauna (< 15% and up to 30%, or more depending on the specific conditions of the site, which may be the case of mountainous or plain areas with a structure built over a motorway at the natural ground level);



❷ Schematic representation of a structure built on an infrastructure located at the natural ground level and requiring ramps for fauna access. Source: Cerema.



❶ Overpass on the A16 motorway. Source: Sanef.

The construction of this ramp is accompanied at the same time by additional consumption of road coverage.



③ Access ramp to the fauna passage. RD64 (70). Source: Cerema.

properly planted). In addition, in certain situations, they allow the use of surplus materials from the earthworks of the infrastructure coverage.



For an infrastructure located at the natural ground level, with a 15% slope, the access ramp extends, for example for a motorway gauge structure (4.75m high), for about thirty metres from the entrance of the passage and up to about forty metres for a structure with a gauge allowing the passage of exceptional convoys (6 to 7m of headroom*).

While the lack of visibility of the passage and the presence of an access ramp to be crossed may limit the efficacy of these passages, they remain very effective when they are properly laid out (in particular

Since wildlife often tends to travel along the infrastructure before accessing the structure, the slopes must remain moderate, regardless of the direction of approach (④).

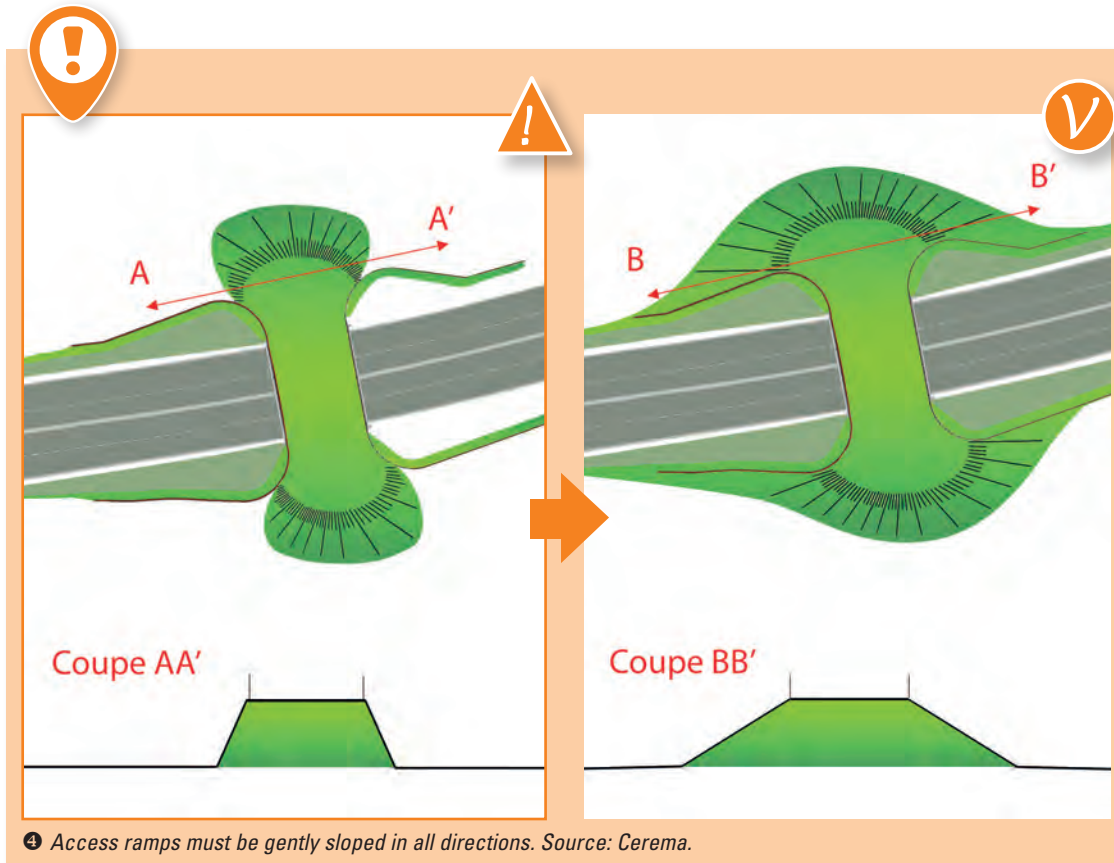

④ Access ramps must be gently sloped in all directions. Source: Cerema.

- or the construction of an arched bridge (⑤), when the breach is not too large (no wider than a dual carriageway). This solution has the advantage of limiting or even eliminating the access slope and thus limiting infrastructure coverage.

■ When the infrastructure has a mixed profile

While the development remains feasible, it is difficult and depends mainly on the slope of the land crossed. This slope must be limited for the structure to be technically and economically feasible and to remain effective⑥.



⑤ Arched bridge RD 31, Moselle. Source: Cerema.

This type of development also requires careful consideration of the management of run-off from the slope.

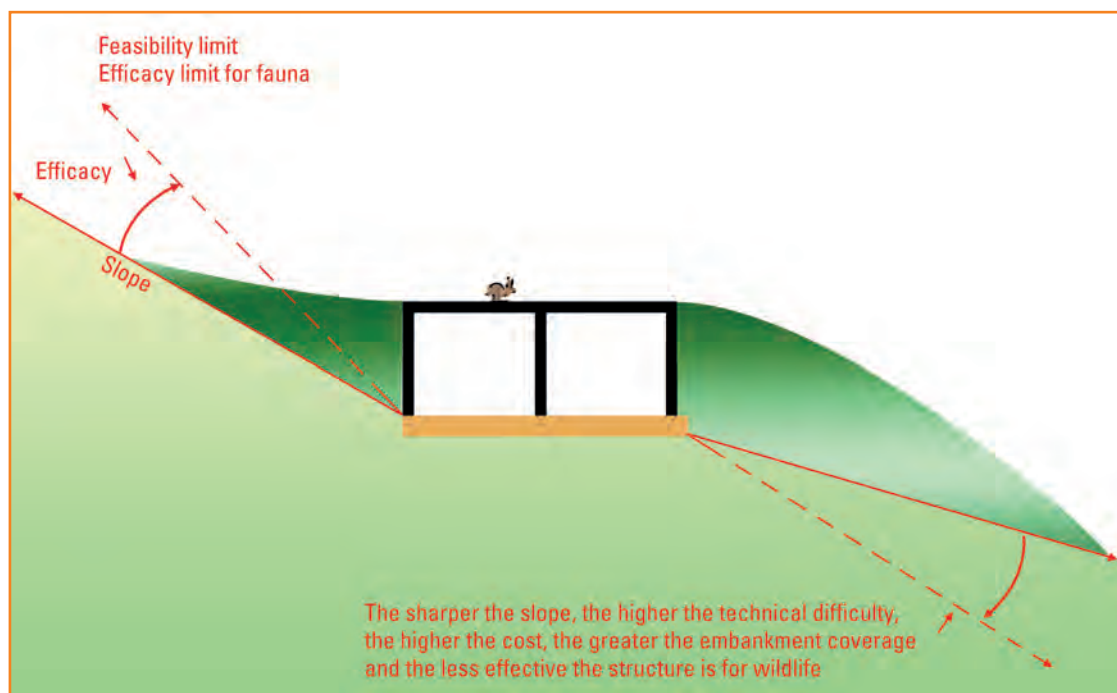

⑥ Schematic representation of an infrastructure with a mixed profile and where the difficulty of the development is generally linked to the importance of the slope of the embankments located on either side of the infrastructure. Source: Cerema.

All fauna underpasses

Built on embankment sections, they are possible as long as the embankment is high enough (7).

When the embankment is not high enough, it is however possible in some cases (filtering soil, outside

a flood zone, deep aquifer, etc.) to create funnel pits in a gentle slope, and build an underpass (8). In this case, it may be necessary to create soak pits (if the soil is adapted) or at least drainage ditches made of draining materials, in order to avoid the presence of water at the entrance or in the structure (9).



7 Underpass on the RN 4. Grand Est region.
 Source: Cerema.



8 Underpass with funnel pit. A88 motorway (Orne).
 Source: Cerema.

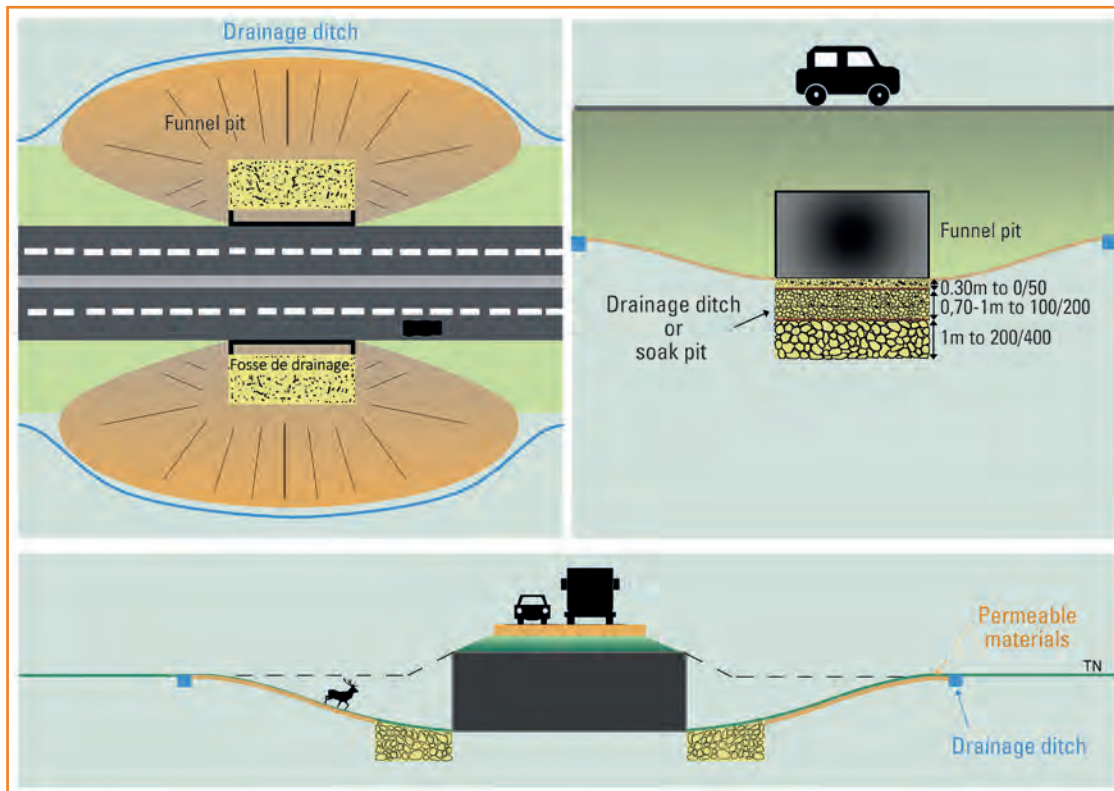

9 Diagrams of the construction of a drainage ditch on the underpasses located below the natural ground level.
 Source: Cerema.



Drainage ditch

The drainage ditch is dug at the entrance of the structure, at the foot of the funnel pit. About 2m deep, it is filled with draining materials that can be of variable size, to facilitate infiltration. From the bottom, the ditch is filled with:

- about 1m of large 200/400 blocks;
- 0.7 to 1m of 100/200 blocks and stones;
- and finally, a covering layer made of finer materials (0/50).

Each layer of materials is separated by a geotextile (permeable to water) to avoid the finest elements descending towards the coarser materials.

The drainage ditch must also be accompanied by:

- the creation of a drainage ditch at the edge of the funnel pit, to prevent surface water from descending into the pit;
- the implementation of a permeable soil layer (10^{-4} m/s permeability coefficient) on the slopes of the pit (mixture of soil + sand or 30/50 materials), in order to avoid gullying and depositing of the finest sediments towards the entrance of the passage, which would ultimately reduce the efficiency of drainage, and the infiltration of water into the pit.

The existence of a mixed profile (see diagram below) may also make it possible to develop an underpass (10).

In this case, the structure has the advantage of being easily drained and the water discharged gravitationally towards the slope (11).

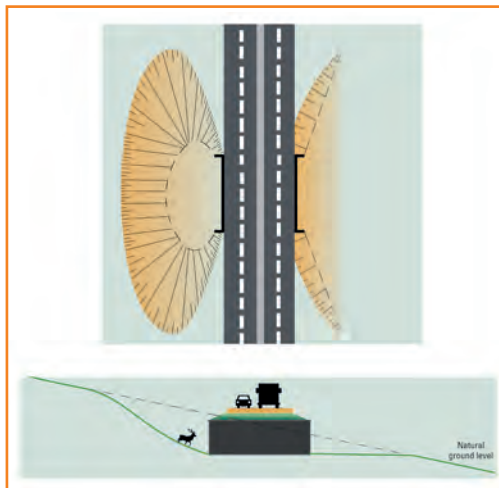

10 Schematic view of a mixed profile underpass with a funnel pit on one side. Source: Cerema.



11 Underpass allowing the evacuation of run-off water towards the slope. Source: Cerema.

Unlike overpasses, underpasses cannot be completely planted due to the absence of watering (rain) and light under the passage. However, when the crossing length remains quite short (equivalent to a dual carriageway with a small embankment), the section of the structure is large enough and it is not very frequented (in particular by human use), a herbaceous layer can develop under all or part of the structure.

The absence of sunshine under the structure also has the disadvantage of creating particular microclimatic conditions, sometimes unfavourable to certain species. The longer the passage, the greater the temperature differences between the outside and the inside of the passage, which can make it more difficult for certain species of vertebrates with a low thermoregulatory capacity, such as reptiles, to pass through, especially in northern France.

An underpass also constitutes a rather dark corridor likely to scare certain species that usually do not frequent dark and/or confined environments (e.g. flying insects). This stress, called the "tunnel effect", tends to increase with the length of the passage (i.e. the size of the embankment) and its reduced gauge.

Underpasses, although less attractive to wildlife, are effective as long as they nevertheless meet needs in terms of positioning, accessibility and external facilities.

Mixed or dedicated passage: a choice depending on the level of restoration issues and the possibility of complementarity with another use

Continuities can be restored either by a passage intended exclusively for fauna (dedicated passage), or by being associated with other uses (waterway, agricultural, forestry or pedestrian), which is then referred to as a "mixed passage".

While it is possible to mix passages, the absence of visual, sound and olfactory disturbances on an exclusive passage nevertheless ensures better efficiency, particularly when dealing with a small sized structure. With the exception of mixed waterway/fauna passages, which have an exclusively natural purpose, **priority must therefore be given to dedicated passages, particularly when faunistic issues are high.**

The multifunctionality of passages can only be envisaged if and only if the conditions are favourable (ecological network and the need for nearby

restorations, adapted access conditions, favourable environments crossed, etc.). The construction of a mixed passage also requires special precautions and very strict construction conditions for it to be effective (see "mixed passages" chapter below).



Does on the dedicated overpass of La Lande. A10 motorway. Source: © VINCI Autoroutes photograph library – Emmanuel Rondeau.

Dedicated passages

These structures are either reserved for the restoration of the most valuable continuities or retained in the absence of other restorations. These are structures that do not perform any other function and that are inaccessible to vehicles. Other uses are restored via other structures (12).

They can be underpasses or overpasses. When they are overpasses, they are characterised by a deck supporting a layer of soil that allows them to be planted and ensure maximum connectivity between the separate habitats. However, precautions are usually necessary on these structures to preserve their specificity and prevent human use (see fact sheet no. 8).

Mixed passages

These structures ensure the restoration of permeability for fauna as well as other functions such as the restoration of a watercourse, an agricultural or forest path or a pedestrian path. They offer the advantage of pooling costs. To make them as effective as dedicated passages, for equivalent issues, the size of mixed passages must be greater in order to take into account the space reserved for other uses and the potential disturbances associated with them (see fact sheet no. 7). Measures to separate functions are sometimes associated to ensure the proper functioning of the area reserved for fauna (see fact sheet no. 8).

■ Mixed waterway passages

All fauna mixed waterway passages restore the hydraulic function of the watercourse intercepted and crossing by fauna through the presence of additional coverage on each bank (13). For an all fauna passage, the dry-standing width depends on the scale of the continuity to be restored. It must be at least 3m on each bank for ordinary passages and can go up to more than 20m for exceptional passages. Dry-standing areas must in



12 Rétablissement agricole dissocié du passage à faune. Source : Luchtfoto Irvin Van Hemert/Pays-Bas.



13 Passage mixte hydraulique/faune. Autoroute A304 (Région Grand Est). Source : Cerema.

fact be in natural materials so that the structures may be considered as all fauna passages. These structures are particularly favourable, as watercourses are often associated with tree-planted areas constituting corridors with a fundamental role for the movement of species.

Although these structures are often temporarily unusable in flood-prone valleys, it is not necessary to make special provisions to ensure a passage under these structures during these periods of heavy flooding (levelling of the dry-standing area on the bankfull flow - Q2 to Q3). Given the issues related to semi-aquatic mammals, provisions must however be considered at least for the passage of this small fauna (see sheet no. 11), especially if the floods last for days or more.

Attention should be paid to discharge structures equipped with dissipation trenches as they can be filled with water for quite long periods and jeopardise the movement of species (14).

It is therefore recommended in all cases to design additional infrastructure coverage with a gentle slope (1 to 5%) towards the watercourse or the centre of the dissipation trench, to allow fauna to move during low overflows, to limit the build-up of water or simply of moisture under the structure.

Within this category of structures, the position of the waterway is quite logically central. When the conditions of the waterway allow it, it is possible to move the river bed to allow permeability of the land on a bank when the

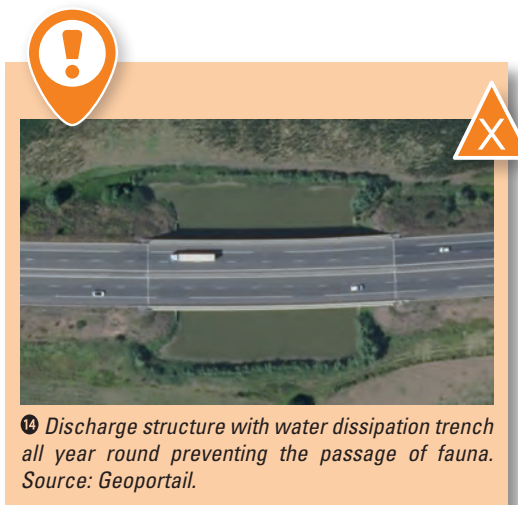

14 Discharge structure with water dissipation trench all year round preventing the passage of fauna. Source: Geoportail.

issues are localised (presence of a forest continuity along a bank 15). However, the minimum size (3m) of the smallest bench* must be respected (see sheet no. 7: "How to size the passage?").

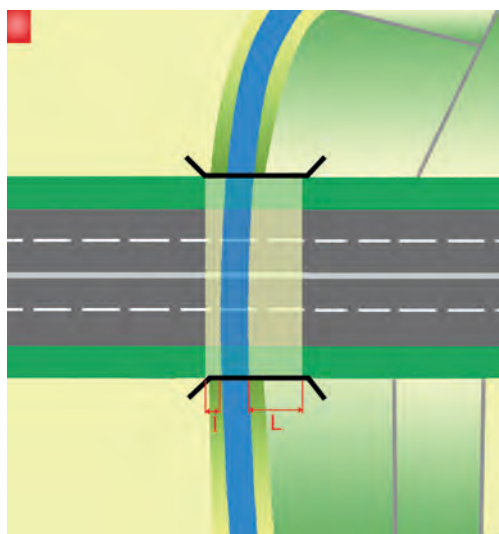

15 Schematic view of an example of the positioning of the waterway in relation to a forest ecological network mainly positioned along a bank. Source: Cerema.

■ Mixed agricultural/forestry/ pedestrian passages

These structures bring together an area reserved for fauna with the restoration of an agricultural or forest path (16 and 17 next page) or simply a pedestrian path.

While human use is compatible with the fauna passage, the path restored for this use must be only lightly used, with a limited number of

passages per day, ensuring that use is essentially or totally restricted to daytime (e.g. installation of barriers, access sign reserved for agricultural or forestry use, etc.). If the structure is also pedestrian, it must not be lit under any circumstances. It is preferable to keep pedestrian paths narrow, well identified and attractive (even artificialised) to concentrate movements. The absence of a guide should not lead walkers to wander all over the structure as this would increase disturbances (olfactory).



16 Mixed agricultural/fauna passage. A34 (Grand Est region). Source: Cerema.



17 Overpass on mixed agricultural/fauna passage. RN 59 (Grand Est region). Source: Cerema.



RN59 – Photographic sensor monitoring of several fauna structures Cerema Est, 2014

Cerema has monitored fauna on several structures as part of the environmental assessment of the RN59, on behalf of DREAL Grand Est.

This monitoring concerned, among other things, three relatively close structures belonging to a 1.5km section, located within the same landscape entity: a mixed fauna/forest overpass (12m), a dedicated fauna underpass (12m) and a road structure (8m). This follow-up was conducted over two one-month periods (spring, autumn).

The results and in particular the comparison of the number of fauna passages showed on these structures that:

- overall, fauna passages are mostly nocturnal;
- the number of fauna in the road structure is almost zero (9 passages in 75 days, and only in the spring);
- while there are more passages on the dedicated structure at night, there are also several passages during the day;
- day crossings on the mixed structure are very rare.

The differences observed between the three structures seem to show that:

- road structures are not very favourable to fauna passages;
- human use of a structure during the day (here, up to 30 daily passages on the mixed structure) reduces the use and efficacy of the fauna passage.

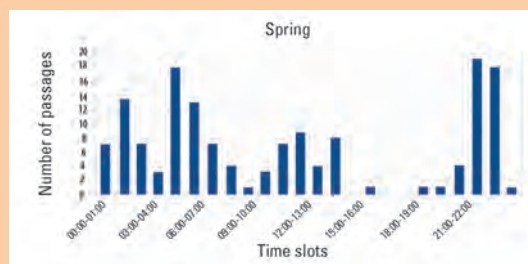

Temporal use of the dedicated passage. Source: Cerema.

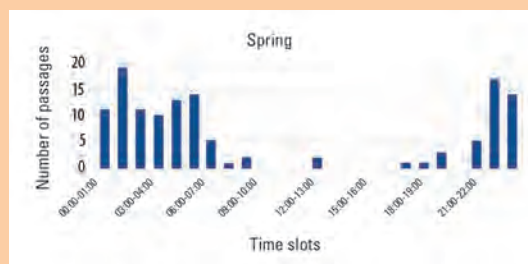

Temporal use of the mixed fauna/forest passage. Source: Cerema.

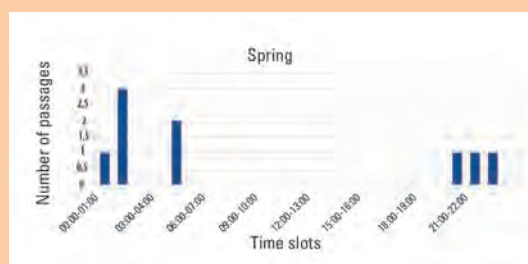

Temporal use of the road passage. Source: Cerema.

For a mixed passage to be considered as such, the path must not be surfaced under any circumstances, as this would create a physical barrier that is not very passable or even impassable for a large number of species, in particular microfauna. This applies more broadly to all sections that may constitute a physical interruption for wildlife approaching the passage.



A structure on which the road is surfaced cannot be considered as an all fauna passage.



Example of a mixed fauna and forest restoration whose road has been surfaced and on which grass verges have been replaced by pavements.

The stabilised (not surfaced) path usually consists of a permeable, often untreated, gravel road layer composed of a mixture of pebbles, gravel and sand.

The configuration of agricultural or forest restoration roads also plays a role in the functional organisation of a fauna passage. On a structure, when the restoration path is perpendicular to the infrastructure, the insertion of fauna facilities is usually quite easy and the guidance of fauna to the entrance is not disturbed. Conversely, and this is often the case, mixed structures support path restorations which, before crossing the infrastructure, often run along the coverage. The organisation of fauna restoration, including the development of entrances, is then more problematic. In this case, the path must be kept as far away from the passage as possible (18).

In order to optimise the efficacy of transparency, the position of the path on the structure must also be defined according to the location and/or characteristics of the continuity to be restored.

The aim is to position the path on the opposite side of the continuity (20 next page). When a homogeneous environment is crossed, the path should simply be positioned alongside the passage rather than in the middle, especially when passages are very wide (19). For pedestrians, the aim is also to concentrate the paths on one side and keep disturbance on the rest of the passage to a minimum.

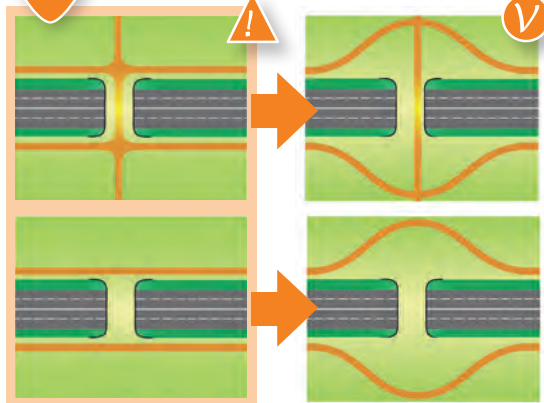

18 Schematic diagram of the positioning of an agricultural or forest path near a fauna passage. Source: Cerema.

For practical reasons, pathways are often located along infrastructure coverage, which can disrupt the longitudinal movements of fauna, especially in open agricultural environments (e.g. grain-producing area). To reduce the impact of these secondary roads, it is recommended to maintain a natural corridor along the infrastructure of at least 10m (a natural space between fencing and the road) (19).

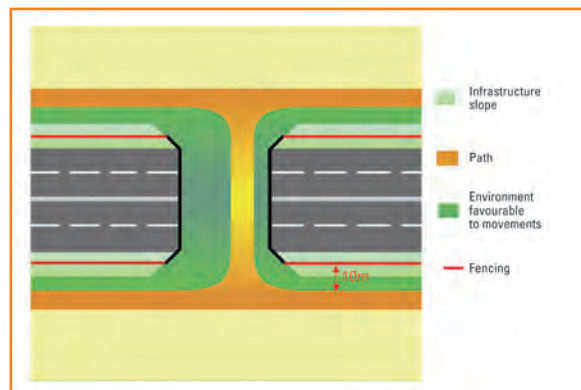

19 Schematic diagram of the maintenance of a 10m natural corridor between the path along the infrastructure and fencing. Source: Cerema.

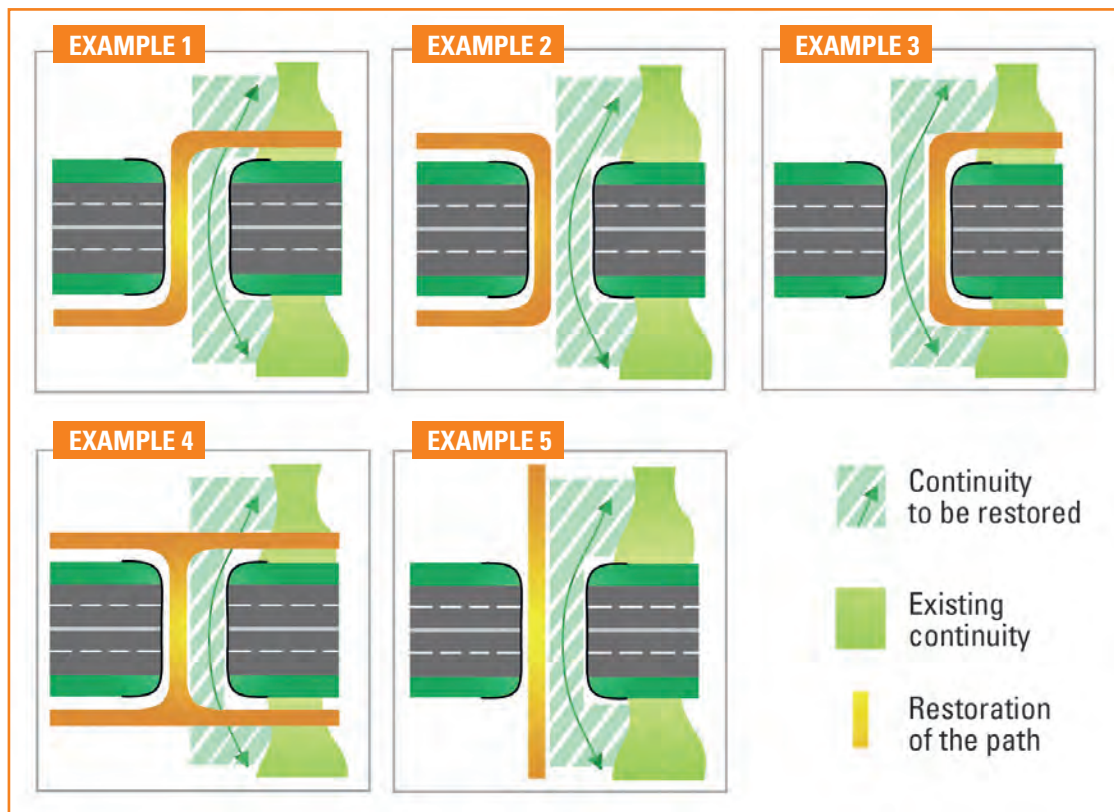

20 Examples of path positioning relative to transversal continuity. Source: Cerema.

Examples 1, 2, 4, 5: the existing continuity is located to the right of the structure. Positioning of the path on the left makes it possible to reconstitute a favourable environment on the structure on the same side as the continuity to be restored and limits or avoids the cutting effect created by the path.

Example 3: even if the path is positioned on the same side as the continuity to be restored, its positioning avoids any additional breaks within the restored corridor.

Mixed passages can also be shifted away from the interrupted ecological network. In this case, the development must include measures to restore connectivity (corridor) between the passage and the intercepted ecological entity (see fact sheet no. 5).

- The mix of fauna and livestock (cattle, horses) is possible, provided that the size of the structure is sufficient and that fencing, where necessary, does not compromise the free movement of fauna.

Likewise, structures restoring low-activity local railway tracks (industrial zone, business zone, etc.)

or hydraulic discharge structures (without a funnel pit) (21) can constitute mixed fauna passages.



21 Functional hydraulic discharge structure for fauna. A304 motorway (Grand Est region). Source: Cerema.



What type of all fauna passage should be chosen?

Depending on the lengthwise profile (with some exceptions), the all fauna passage is:

- an underpass: when the infrastructure is embanked;
- an overpass: when the infrastructure is excavated (or exceptionally slightly embanked).

Depending on the issues and the possibilities of complementarity with other uses, the all fauna passage is:

- a dedicated all fauna passage: when continuity issues are particularly high and/or there is no need to restore other uses in the vicinity;
- a mixed all fauna passage: when it is possible to restore other uses on the same structure:
 - mixed all fauna/waterway passage: structure providing hydraulic transparency and with 3m high land overpasses on each bank of the river,
 - mixed all fauna/agricultural/forest/pedestrian passage: structures with a stabilised (NOT SURFACED) path for vehicles or pedestrians, combined with a sufficiently large planted area to ensure crossing by fauna.

FACT SHEET

7 How to size the passage?

A fauna passage can be considered a corridor segment. However passages do not offer the same advantages. It is logically established that the larger the passage and the shorter its span, the lower the physical barrier will be and the more attractive and effective the structure will be for fauna. The number of species using the structure is partly related to the size of the structure.

However, the cost of the structure is also proportional to its size. All fauna passages must therefore be implemented to restore the highest issues and their size must be adapted to the level of transparency to be restored. The objective is to restore, in all cases, the passage of the maximum number of species taking into account the possibilities of movement of all fauna and the cost of the structure.



Average number of animal sightings per class of structure width

Species concerned:

fox, roe deer, hare, badger, stone marten, weasel, wild boar and deer.

Representativeness

(N = number of passages tracked per class of structure width):

Class 1: up to 10m	N = 5 structures
Class 2: 11-20m	N = 5 structures
Class 3: 21-30m	N = 3 structures
Class 4: 31-40m	N = 1 structure
Class 5: 41-50m	N = 2 structures
Class 6: 51-60m	N = 0 structure
Class 7: 61-186m	N = 5 structures

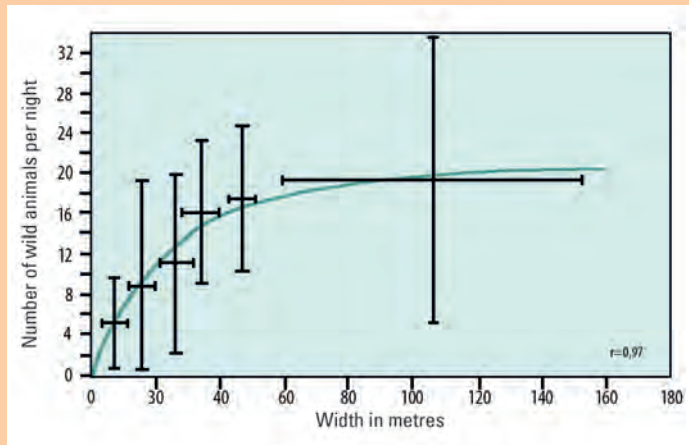

Source: according to Pfister et al. (1997).

Shown: regression curve, class range and frequency variations.

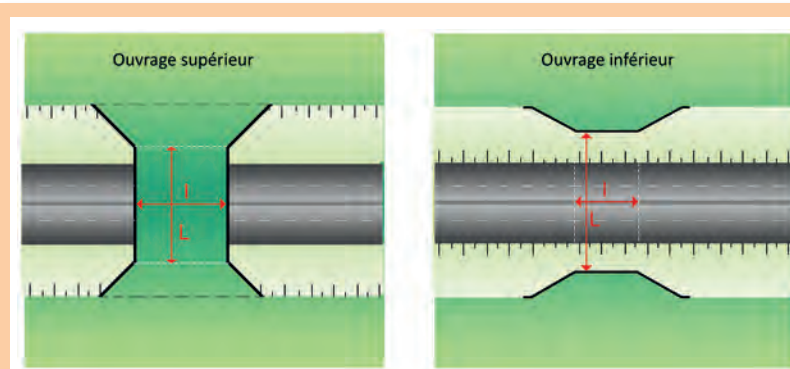

Source: Cerema.

The length (L) of the structure corresponds to the length of the deck for overpasses and to the length of the cover for underpasses.

The width (w) of a structure corresponds to the width at its centre.



Although the term width is commonly used, it actually means the effective width or usable minimum width of the fauna structure.

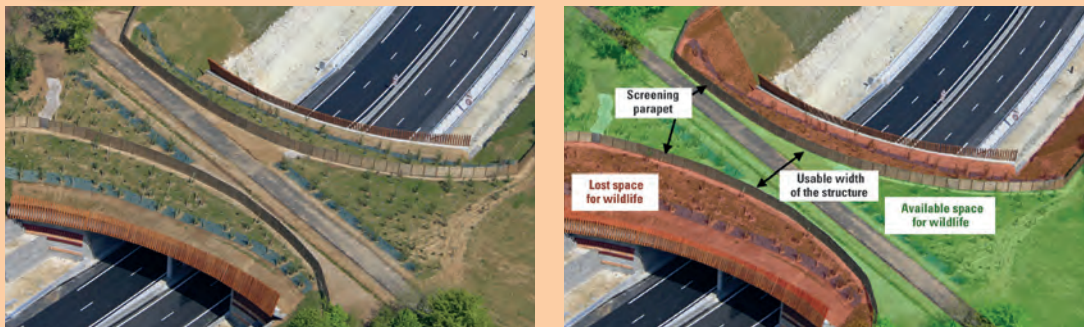

Mixed overpass whose total width is not accessible to fauna. Source: DIR Nord.

Width depending on the scale of the continuity to be restored and whether the passage is mixed or not

Whether overpasses or underpasses, their width is essentially conditioned by the scale of the issues. Also, the greater the advantage provided by the continuity and the higher the issues, the larger the structure will have to be.

The advantage of a passage also depends on its tranquillity, its layout or the space available for fauna. Therefore, because it is less effective for an equivalent efficacy objective, a mixed agricultural/forestry/pedestrian passage will need to be wider than a fauna-specific restoration. The aim is both to maintain and develop (by planting, etc.) a sufficiently available width for the fauna, while minimising human disturbance. A larger width allows the passage of specialised species, often small in size, because it is possible to create their specific habitats.

Similarly, for waterway structures, while the opening of the passage is a decisive point for its functionality, the width of the dry-standing area and its layout, corresponding to the environment actually usable by terrestrial fauna, are just as important. These two components

must therefore be taken into account when defining the characteristics of the structure.

Depending on the scale of the continuity to be restored, a passage category with a reference size is recommended. **However, this reference size needs to be adapted according to the special characteristics of the project, the specific issues of the environments crossed and the technical constraints.**

Ordinary all fauna passages

These passages are positioned primarily on corridors of local interest. Due to their size, they ensure a minimum amount of transparency favourable to many species of small and large fauna. They allow a minimum number of exchanges, genetic mixing of the populations and maintain the possibility of conquering new territories. Although they give deer and wild boar ungulates the possibility of crossing, they do not, however, make it possible to ensure optimal transparency for deer.

These passages, when they are dedicated, have a size of 20m +/- 5m depending on the extent of movements and the corridor to be restored (❶).



❶ *Dedicated ordinary all fauna underpass. RN 4 (54). Source: Cerema.*

This reference width is increased to 25m (+/-5m) if the passage is also used for the restoration of an agricultural or forestry or pedestrian path (hiking path) (❷) provided it is not surfaced and its width does not exceed 5 metres.



❷ *Ordinary mixed all fauna overpass. A36 motorway (Grand Est region). Source: Google Earth.*

For waterway/fauna passages, care should be taken to maintain an available space of 3m under the structure on each bank (❸).

Remarkable all fauna passages

These structures ensure both the dispersal of a large number of species of small and large fauna and in particular meet the needs of large ungulates such as deer. These are however relatively expensive passages and should be reserved for fauna-rich habitats or for restoring major continuity issues.

Depending on the importance of the continuities to be restored:

- in the case of a corridor of local interest, with the movement of deer or a forest area of interest (< 500ha):
 - a dedicated or mixed waterway passage of 25m +/- 5m (by maintaining a space of 7m beneath the structure on both banks if it is a waterway structure),
 - a 30m +/- 5m passage if it is a mixed agricultural or forest passage (if the structure also has a hydraulic function, it will be necessary to ensure that there is at least 7m dry-standing space for fauna on each side of the waterway).

- ❶ Structure with a reference width (W) for this category of passage that is sufficient to maintain a dry-standing area of a size equal to or greater than the recommended width (w). The latter depends on each structure category.

For example, for a 20m wide ordinary all fauna structure, the size of the dry-standing area must be greater than 3m.

- ❷ Oversized structure (W') in relation to the reference width (W) in order to respect the minimum size of the dry-standing area (w).

For example, for a 20m ordinary all fauna structure, if the watercourse is 22m wide, the structure will be oversized to maintain a dry-standing area of at least 3m. The width of the structure will thus be increased to: $22+2 \times 3\text{m} = 28\text{m}$.

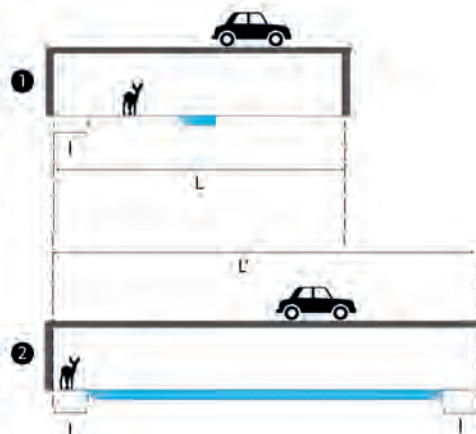

- ❸ Adjustment of the width of the structure to take into account both the width of the watercourse and the restoration of land-based continuities. Source: Cerema.

Even if deer are not yet present, the potential for recolonisation can also be studied and anticipated. It will then be possible to justify the creation of a favourable structure before its arrival;

- when issues are more important, in particular for corridors of regional interest, when there are major continuity issues within a type 1 ZNIEFF or when crossing vast forest areas (> 500 ha): **a structure of 35m +/- 5m (4) (or 40 +/- 5m for mixed passages** and for waterway structures with less than 10m reserved for fauna on each side of the watercourse.



4 Example of a remarkable all fauna passage on the A1 motorway in Switzerland. Source: AURA/Emanuel

Exceptional all fauna passages

The purpose of these passages is to offer large natural areas, either by the construction of a very large overpass, or by the conservation of all or part of these habitats in the case of a viaduct or tunnel.

Practically all biological flows can be restored due to their dimensions (50m). Due to the space available, they make it possible in particular to create the natural habitats of specialised species. They therefore ensure maximum, or even complete, connectivity for a maximum number of faunistic groups, including invertebrates and micromammals*. Although they are effective, these structures are very expensive and must be unquestionably justified by the presence of environments and networks of very high ecological value.

Depending on these issues, a distinction will be made between:

- **50m +/- 10m (5)** passages: they are recommended when the infrastructure interrupts a continuity between or within protected sites (national natural* reserve, national park, regional natural reserve). They may also be justified by the existence of a transition living area for protected species or the crossing of large forest areas (> 2,000ha). The space reserved for fauna on each side of a waterway must be at least 15m;
- **passages of more than 60m** that can go up to several hundred metres: they are reserved for the most important continuities between Natura 2000* sites, within the same Natura 2000 site (special conservation area) or to restore the functionality of a corridor of national importance. For a waterway structure, the area reserved for fauna on each bank must also be at least 20m.



5 Example of an exceptional passage between Bern and Solothurn in Switzerland. Source: AURA/Emanuel Ammon.

For overhead crossings, such passage widths require:

- either the construction of a covered trench (6). Unlike tunnels, the construction of a large structure by digging from the surface is preferred. This means that the infrastructure is excavated.



6 Covered trench of the A19 motorway in the crossing of the forest of Montargis. Source: Arcour.

The concept is based on the construction of a trench, held on each side by two parallel retaining walls over which a roof slab is placed. This slab is then covered with earth and developed to restore natural habitats;

- either tunnelling (7), which involves digging out an underground gallery within the rock through which to pass the infrastructure.

Although this is, in most cases, a technical choice or necessity related essentially to the design of the infrastructure, these structures benefit fauna when the surface is not developed or urbanised. The main advantage of tunnelling the infrastructure is to ensure the preservation of surface habitats over the entire (sometimes extensive) length of the structure.

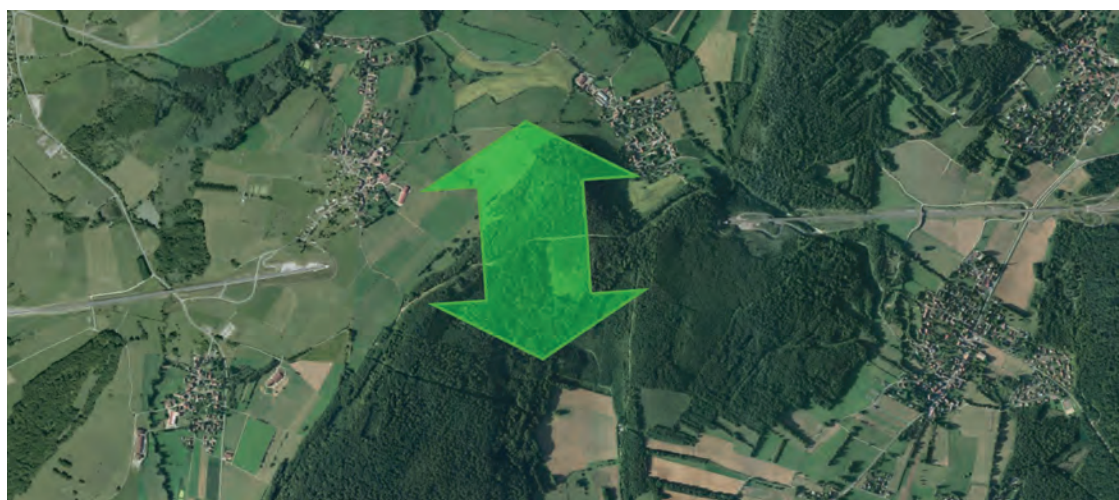

7 Chavanne Tunnel (1,970m long). LGV Rhin-Rhône. Source: Geoportail.

When fauna underpasses are very wide and short, they are usually called viaducts (8). Like tunnels, they restore or maintain immediate and rapid possibilities of movement for all fauna and, above all, they maintain the integrity of the habitats of species presenting a very high issue and thus limit destruction.

For these passages, however, some restrictions may exist if the headroom* is too small, as areas of shade or a view of the flow of vehicles may limit the effectiveness of the transparency.

If the identified issues require an exceptional all fauna passage, the headroom must be at least 4m to keep disturbance to a minimum. If the structure

is built in a forest environment, the headroom will however be increased to 10m to take into account the issues related to flying fauna.



8 Jaulny viaduct (Grand Est Region). LGV Est européenne. Source: RFF (the French rail network)/CAPA/Laurent Rothan (TOMA).

Level of issues of the ecological network ⁵	Width of the passage (underpass or overpass) in the centre of the structure		Category
	Dedicated or mixed waterway	Mixed agriculture/forestry (path < 5m wide) Mixed agriculture/forestry & waterway	
<ul style="list-style-type: none"> Major continuity issues between nearby, highly concentrated Natura 2000* sites or within a Natura 2000 site and/or ecological network of national importance. 	<p>> 60m</p> <p>For waterway structures, the width of the two dry-standing areas must, in all cases, be > 20m</p>	<p>> 60m</p> <p>For waterway structures, the width of the two dry-standing areas⁶ must, in all cases, be > 20m</p>	<p>Exceptional all fauna (or landscape) passages</p>
<ul style="list-style-type: none"> Significant continuity issues between or within protected sites (RNN, PN, RNR) and/or vast forest area (> 2,000ha) capable of hosting mosaics of intraforest habitats and/or ecological network with a vital transition zone for maintaining populations of large high issue mammals (e.g., lynx, which is highly dependent on forest continuity). 	<p>50m +/- 10m</p> <p>For waterway structures, the width of the two dry-standing areas must, in all cases, be > 15m</p>	<p>50m +/- 10m</p> <p>For waterway structures, the width of the two dry-standing areas⁶ must, in all cases, be > 15m</p>	
<ul style="list-style-type: none"> Ecological network of regional importance. and/or significant continuity issues within a Type 1 ZNIEFF and/or extensive forest area (> 500ha) and/or ecological network with significant continuity issues for protected and heritage species. 	<p>35m +/- 5m</p> <p>For waterway structures, the width of the two dry-standing areas must, in all cases, be > 10m</p>	<p>40m +/- 5m</p> <p>For waterway structures, the width of the two dry-standing areas⁶ must, in all cases, be > 10m</p>	<p>Remarkable all fauna passages</p>
<ul style="list-style-type: none"> Corridor of local interest with deer movement and/or forest area of interest (< 500ha). 	<p>25m +/- 5m</p> <p>For waterway structures, the width of the two dry-standing areas must, in all cases, be > 7m</p>	<p>30m +/- 5m</p> <p>For waterway structures, the width of the two dry-standing areas⁶ must, in all cases, be > 7m</p>	
<ul style="list-style-type: none"> Corridor of local interest without deer movement. 	<p>20m +/- 5m</p> <p>For waterway structures, the width of the two dry-standing areas must, in all cases, be > 3m</p>	<p>25m +/- 5m</p> <p>For waterway structures, the width of the two dry-standing areas⁶ must, in all cases, be > 3m</p>	<p>Ordinary all fauna passages</p>

Alternative criteria, ⁵ the choice depends on the overriding criterion.

Agricultural and forestry paths are not part of the dry-standing areas reserved for fauna. ⁶

■ Criteria for adjusting the width of the passage according to the issues

If reference sizes have been indicated according to the importance of the continuity issues, these recommendations should be modulated

according to the local context and the characteristics of the project. A margin of manoeuvre (+/- Xm) is thus proposed for which the discussion elements indicated below can be used to facilitate the definition of the final size of the structure.

Criteria likely to tend towards the upper limit of the width category

Specific issues of species or populations of species (presence of a heritage species).
Special ecological development (reservation of a specific area for a species that is demanding in terms of habitat).
Few cost differences with a smaller structure or economic gain thanks to an innovative technique.
Low to medium level of transparency. <ul style="list-style-type: none"> • few small fauna passages due to siting difficulties (e.g., excavated area); • interval between all fauna passages is close to the minimum average.
Difficulty of choice with the higher category.
Isolated ecological network (the only area of interest within a deteriorated space) where movement will potentially be concentrated.
For mixed crossings, the extent of disturbance from other uses (a few pedestrians crossing per day is different from a regular use by motor vehicles).
Accumulation of unrelated issues (unlike a large forest area classified as ZNIEFF and RN -> identical issues).
Positioning of the structure is shifted in relation to the highest issues within the continuity (shifted with respect to a movement route, shifted with respect to the continuity's specific habitat, etc.).
Development of constrained surroundings (difficult access to the structure, presence of breaks or obstacles* at the exit of the passage).
Significant width of the continuity crossed.

Criteria likely to tend towards the lower limit of the width category

Particular technical constraints preventing the construction of a larger sized passage according to standard and acceptable conditions.
Cost disproportionate to the issues.
Presence of other fauna passages nearby (< 1km).
Remarkable connection with other fauna passages.
For mixed passages, the small amount of disturbance from other uses (e.g. exceptional traffic).

Additional all fauna passages

The provision of small passages (width > 7m) may also contribute to the defragmentation of an infrastructure.

However, these structures must be reserved for:

- the development of large sections, where issues are low, in order to give minimum transparency to the infrastructure (see fact sheet no. 5);
- in addition to other larger passages, in vast and very diverse habitats (e.g. medium altitude, bocage, etc.).

Category	Level of issues of the ecological network	Width of the structures at the centre of the structure	
		Underpasses	Overpasses
Additional passes	<ul style="list-style-type: none"> • Ordinary habitat with total absence of transparency for more than 3km. • Ordinary habitat with absence of all fauna passage for more than 5km but presence of a small fauna passage. • Extensive and highly diversified habitat in addition to other fauna passages (already meeting general recommendations). 	7m minimum	7m minimum



Ecological networks of national importance

Ecological networks of national importance (CEIN) were defined within the framework of the national TVB (green and blue grid) guidelines (Decree no.2014-45 dated 20 January 2014). CEINs correspond to large coherent ecological areas, at the national level. They give material form to high issue areas common to several regions or shared between a region and a border country. Maps divided into major categories of continuity (thermophilic open environments, wooded environments, etc.) are available.

They are usually taken up and adapted in the SRCEs.



Ecological networks of national importance: wooded environments Source: MNHN/SPN.

Ecological networks of regional importance

These are the ecological networks used in the development of the SRCEs (and included in the SRADDET) to form the regional green and blue grid*.

Ecological networks of local importance

The continuities defined at the municipal level by the analysis of the territory or already defined in the planning documents (in particular ScoT, PLU, PLUi) take into account the SRCEs and identify all the areas and elements that contribute to the TVB and its functionality.

Networks of national or regional interest are generally very extensive and encompass several lower rank continuities. Also, although taking into account the level of importance of a continuity must result in the construction of a structure of corresponding size at this level, the

aim is not to design the entirety of all fauna passages within this continuity with such dimensions. The aim is to have a progressive approach so that at least one restoration structure has the required dimensions of its level within each continuity (9).

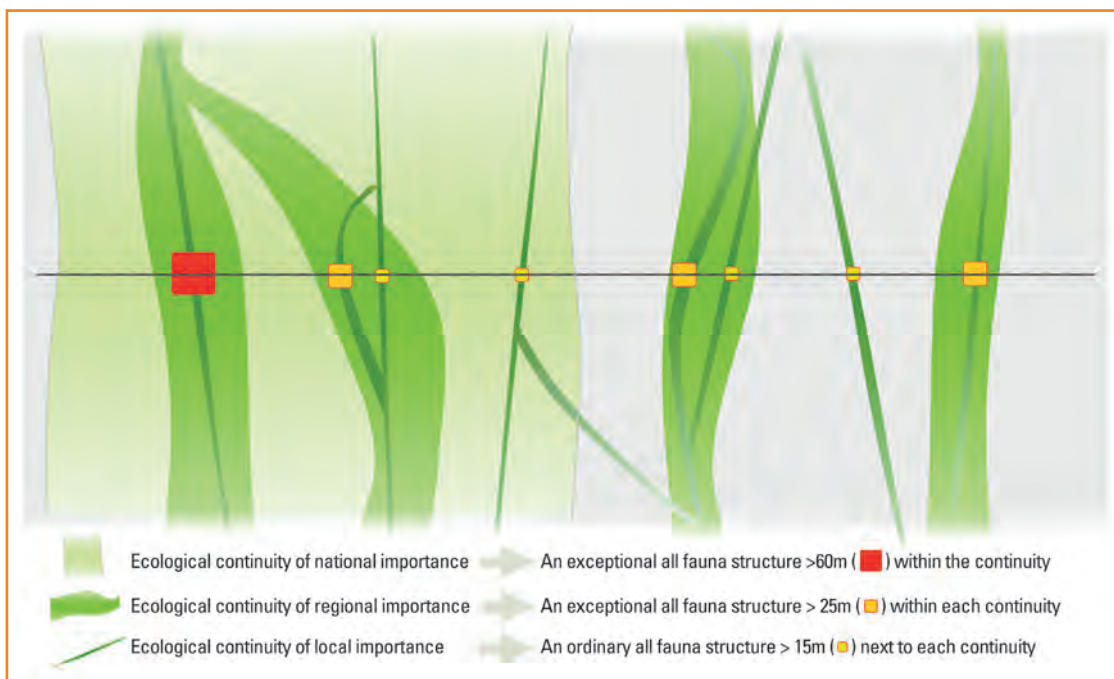

9 Schematic representation of the distribution of passage categories according to the importance of ecological networks. Source: Cerema.

Width depending on the length of the crossing

For all fauna overpasses

For overpasses, difficulties are mainly encountered with the smallest structures (ordinary all fauna structures 20m +/- 5m) whose functionality can be restricted if the crossing length is too long (corridor effect).

To limit this effect, care should be taken to comply with the following ratio:

$$\frac{\text{width}}{\text{Length}} > 0,4$$



Example: for a passage length of 30m, an ordinary passage for which a width of 20m is retained, the compliant ratio is $R1 = 0.66$.

However, with a length of 60m, compliance with the recommendation requires the width of the structure to be increased to a minimum of 24m.

For all fauna underpasses

The construction of an underpass must comply with the following minimum construction conditions:

$H > 3.50\text{m}$
[> 4m if deer are present
or exceptional all fauna passage]

$$\frac{\text{width} \times \text{Height}}{\text{Length}} > 1,5$$

When crossing forest areas, it may be necessary to increase the height of the structure to take into account issues related to flying fauna. For the largest structures (exceptional passages), it is recommended to increase this height to 10m when crossing forest areas.



Example: for a crossing length of 30m, an ordinary structure for which a width of 15m and a height of 3.5m (in the absence of deer) are selected, the compliant ratio is $R2 = 1.75$.

If, on the other hand, the crossing length is 50m, compliance with the recommendation requires either increasing the width of the structure to 21.5m or increasing the height to a minimum of 5m.

For certain situations, prefer two smaller sized passages to a larger sized passage

The presence of close but important issues may lead to opting for two smaller sized structures rather than the initially recommended size. However, this possibility is linked to the presence of special conditions:

- when two continuities are close, connected and belong to the same ecological corridor (10 next page);
- when the environments crossed are rich, consist of several landscape structures that lead to dispersed exchanges over a vast ecological corridor.

However, the functionality of a smaller structure is not equivalent. For this reason, both structures

must at least respect the minimum sizes of the category ranked just below for a single passage (see example below).



Example: for an ecological network of regional importance, the recommended structure size is $35\text{m}^{+/-5\text{m}}$ for a dedicated structure. If two structures are chosen, the width of each of the two dedicated structures must be at least $25\text{m}^{+/-5\text{m}}$ (recommended size for example for local ecological corridors with movement of deer), i.e. 50m of total restoration width distributed over two structures.

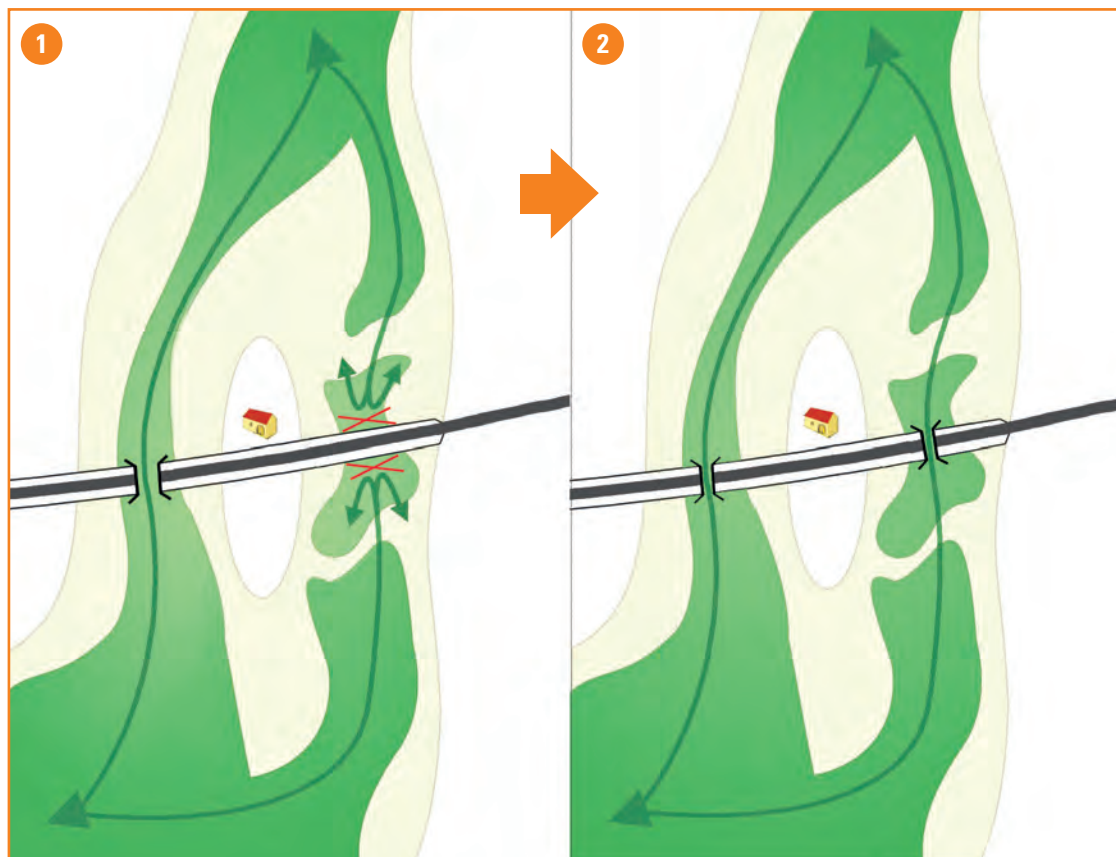

10 Diagram representing two close and connected ecological networks justifying the creation of a small sized crossing structure on each of them (2) rather than one single large sized structure (1). Source: Cerema.

Width depending on the presence of target suites with a specific issue

The dimensions indicated are designed to provide optimal efficiency in restoring ecological networks, depending on their interest. The presence of heritage and/or protected species can also lead to exceeding recommendations. Each situation falls within this specific case.

The width of the structure is then defined according to the results of studies of the spatial distribution and organisation of species habitats (home range*, movement route) and the ecological functioning of the populations of these species (density, distribution, etc.).



Example: in the context of the Strasbourg west bypass project, taking into account the large hamster led the concession company to propose the construction of two large sized overpasses, within an agricultural area lacking well-localised ecological networks (apart from a few grassy paths), but within the living area of the hamster population.

In France, the common hamster is only present in Alsace. It is a protected species whose presence is endangered on the national territory.



How to size the structure?

The width of a passage is above all defined according to the scale of the continuities to be restored. Logically, the greater the issue of continuity to be restored, the wider the structure must be and it should make it possible to create natural habitats corresponding to the diversity of user species.

If the passage is mixed (through to remarkable structures, because beyond this it is not essential), it is necessary to provide for additional widening in relation to a specific passage so that the available reserved space for fauna remains equivalent and maintains maximum tranquillity.

For overpasses, the width must also take into account the length of the crossing to avoid the "corridor" effect. To limit this effect, the following ratio must be followed:

$$\frac{\text{width}}{\text{Length}} > 0.4$$

Similarly for lower structures, the height must be at least 3.5m (4m in the presence of deer or for exceptional all fauna passages) and comply with the following requirements:

$$\frac{\text{width x Height}}{\text{Length}} > 1.5$$

When crossing forest areas, the height will be increased to 10m for exceptional all fauna passages in order to take into account flying fauna.

Waterway structures are sized both according to the value of the continuity, but also taking into account the coverage of the watercourse under the structure, so as to have a minimum dry-standing width on each bank.

In certain situations (close and connected continuities, rich environments), it is possible to opt for two smaller structures rather than a larger one.

The presence of a species with a particular issue may also, on its own, lead to the recommendation of a large structure, especially if its ecological requirements require the creation of a mosaic of natural habitats.



ANALYSIS OF ECOLOGICAL CONTINUITIES

Continuity restoration structure according to its level of issues¹

Additional restoration structure to provide sufficient overall permeability

- Continuity issues between the nearby highly concentrated Natura 2000 or within a Natura 2000 site
- and/or ecological continuity of national importance
- Continuity issues between or within protected sites (RNN, PN, RNR)
- and/or vast forest area (> 2.000 ha) capable of hosting mosaics of intra-forest habitats
- and/or ecological continuity with a vital transition zone for maintaining populations of large, high issue mammals (e.g. lynx, which is highly dependent on forest continuities)
- Ecological continuity of regional importance
- and/or significant continuity issues within a Type 1 ZNIEFF
- and/or extensive forest area (> 500 ha)
- and/or ecological continuity with significant continuity issues for protected and heritage species
- Corridor of local interest with deer movement
- and/or forest area of **interest** (< 500 ha)
- Corridor of local interest without deer movement

- Ordinary habitat with total absence of transparency for more than 3km
- Ordinary habitat with no all fauna passages for more than 5km but possibilities for a small fauna passage
- Extensive and highly diversified habitats in addition to other all fauna structures

1 Recommended width
Overpass = underpass

If dedicated or mixed waterway structure

If mixed/forestry or mixed farming/forestry + waterway structure

> 60m

For waterway structures, the width of the two dry-standing areas must, in all cases, be > 20m

> 60m

For waterway structures, the width of the two dry-standing areas² must, in all cases, be > 20m

50m

+/- 10m
For waterway structures, the width of the two dry-standing areas must, in all cases, be > 15m

50m

+/- 10m
For waterway structures, the width of the two dry-standing areas² must, in all cases, be > 15m

35m

+/- 5m
For waterway structures, the width of the two dry-standing areas must, in all cases, be > 10m

40m

+/- 5m
For waterway structures, the width of the two dry-standing areas² must, in all cases, be > 10m

25m

+/- 5m
For waterway structures, the width of the two dry-standing areas must, in all cases, be > 7m

30m

+/- 5m
For waterway structures, the width of the two dry-standing areas² must, in all cases, be > 7m

20m

+/- 5m
For waterway structures, the width of the two dry-standing areas must, in all cases, be > 3m

25m

+/- 5m
For waterway structures, the width of the two dry-standing areas² must, in all cases, be > 3m

To be adjusted according to the more or less favourable criteria linked to the specificities of the project

Dedicated

> 7m

overpass or underpass

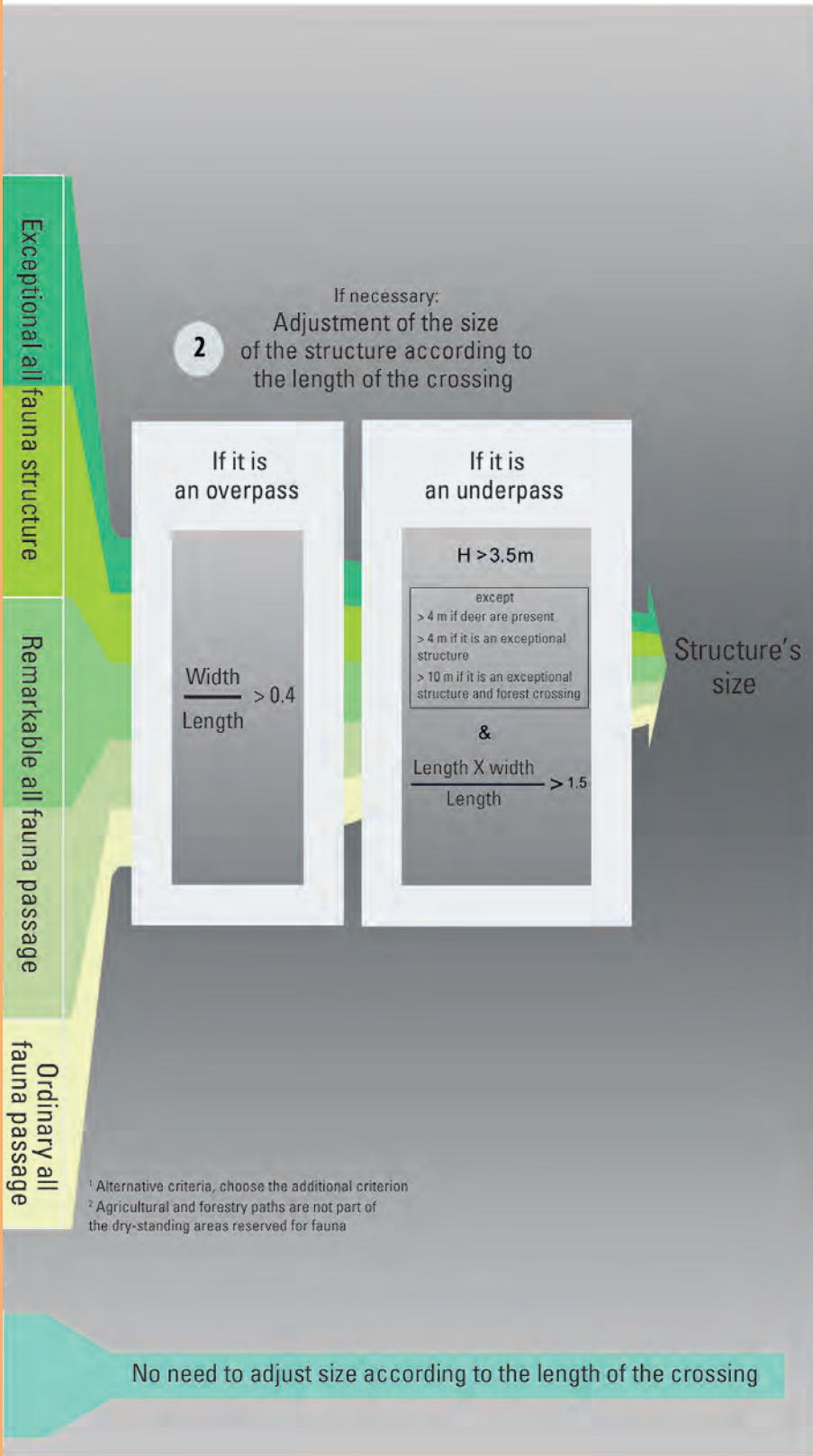

¹ Alternative criteria, choose the additional criterion
² Agricultural and forestry paths are not part of the dry-standing areas reserved for fauna



Group of species	Species	All fauna passage				Small fauna passage						
		Exceptional		Remarkable		Ordinary		Structure not dedicated to fauna equipped with grassy benches*	Canopy passage	Amphibian tunnel (two-way)	Small waterway structure equipped with a bench*	Dry talweg structure
Overpass (covered trench, tunnel)	Underpass (viaduct)	Overpass	Underpass (viaduct)	Overpass	Underpass	Overpass or underpass						
Ungulates	Deer	●	● (if H > 4m)	●	● (if H > 4m)	○	○ (if H > 4m)	○	x	x	x	x
	Roe deer, chamois	●	●	●	●	●	○	x	x	○	○	○
	Wild Boar	●	●	●	●	●	○	x	x	○	○	○
	Brown bear	●	●	●	●	●	○	x	x	x	x	x
	Lynx	●	●	●	●	○	○	x	x	○	○	○
	Wolf	●	●	●	●	●	●	x	x	x	x	x
	Fox	●	●	●	●	●	●	x	x	●	●	●
	Wild cat	●	●	●	●	●	●	x	x	●	●	●
	Badger	●	●	●	●	●	●	x	x	●	●	●
	Otter, European mink	○	● (Mixed waterway) ○ other	○	● (Mixed waterway) ○ other	○	● (Mixed waterway) ○ other	○ (Mixed waterway underpass) ○ Overpass	x	○	●	○
Carnivores	Stone marten Weasel	●	●	●	●	●	●	●	○	●	●	●
	Other small mustelid	●	●	●	●	●	●	●	x	●	●	●
	Genet	●	●	●	●	●	●	●	?	●	●	●



Lagomorphs	Hare	•	•	•	•	•	•	•	•	•	•	•	•	x	○	○	○		
	Rabbit	•	•	•	•	•	•	•	•	•	•	•	•	x	○	○	○		
	Insectivores	Hedgehog	•	•	•	•	•	•	•	•	•	•	•	•	x	○	○	○	
		Shrew	•	•	•	•	•	•	•	•	•	•	•	•	x	•	•	•	
	Rodents	Red squirrel	•	•	•	•	•	•	•	•	•	•	•	•	•	•	x	x	
		Dormouse	•	•	•	•	•	•	•	•	•	•	•	•	•	•	x	x	
		Mouse	•	•	•	•	•	•	•	•	•	•	•	•	•	•	•	•	
		Vole	•	•	•	•	•	•	•	•	•	•	•	•	•	•	•	•	
		Beaver	•	•	•	•	•	•	•	•	•	•	•	•	•	x	○	○	○
			○	○	○	○	○	○	○	○	○	○	○	○	○	○	○	○	○
	Reptiles	Snake	•	•	•	•	•	•	•	•	•	•	•	•	x	○	○	○	
		Lizard	•	•	•	•	•	•	•	•	•	•	•	•	x	○	○	○	
		Tortoise	•	•	•	•	•	•	•	•	•	•	•	•	x	○	○	○	
Amphibians	○	○	○	○	○	○	○	○	○	○	○	○	○	○	○	○	○		
	○	○	○	○	○	○	○	○	○	○	○	○	○	○	○	○	○		
Terrestrial invertebrates	Dry habitat species	•	•	•	•	•	•	•	•	•	•	•	•	x	○	?	?		
	Wetland habitat species	•	•	•	•	•	•	•	•	•	•	•	•	x	○	?	?		
	Bats	•	•	•	•	•	•	•	•	•	•	•	•	○	○	x	○		

○ Optimal solution?
 ● Likely to be used depending on local conditions and size
 ○ Exceptional use also depending on the size of the structure

○ ? Unknown, more experience required
 x Inappropriate

FACT SHEET 7

How to design and develop all fauna passages?

While the effectiveness of a passage depends on its location and technical characteristics, its use by fauna also depends on its integration into the environment, linked, in particular for overpasses, to the layout of the deck and, more generally, to the development of immediate surroundings. Particular attention must therefore be paid to the details of the design and their future management, so that the structure is favourably integrated into the ecological network and its future effectiveness ensured.

These conditions require a broad vision, going beyond the passage and the construction coverage, so that the overall development is best

integrated and that, in the long term, it is effective and sustainable over time.



*Example of the layout of the deck of a structure.
Source: Vinci Autoroutes/ASF network.*

Development of overpasses

Reduction in crossing length: abutments on front wall

In order to guide fauna as far as possible towards the entrance of the structures and to have the shortest possible crossing length on the narrowest part of the structure (usually the centre), it is recommended to widen the funnel as much as possible (entrance of the passage).

It is not necessary to incorporate curved (often too expensive) funnels into the structure, but to prefer a rectangular deck from which flared funnels will be created. In particular, priority will be given to making abutments on the front wall (1 and 2 on next page), in order to bring the funnel as close as possible to the infrastructure.

The abutment of the structure (part located on the bank intended to support the weight of the deck) must be designed with a vertical wall (sheet piling, concrete wall) as close as possible to the roadway (2, 2A, 4 next page).



1 Overpass fitted with an abutment on the front wall.
Source: ATMB - Arnaud Lesueur.

This abutment is generally associated with "winged" retaining walls (concrete walls, gabions*, etc.) at the structure's exit, with a wide opening (> 45°) (next 2, 2B page).

This comprises a retaining system which, once loaded with materials, makes it possible to increase the width of the entrances and thus reduce the length of passage of the structure in its narrowest part.

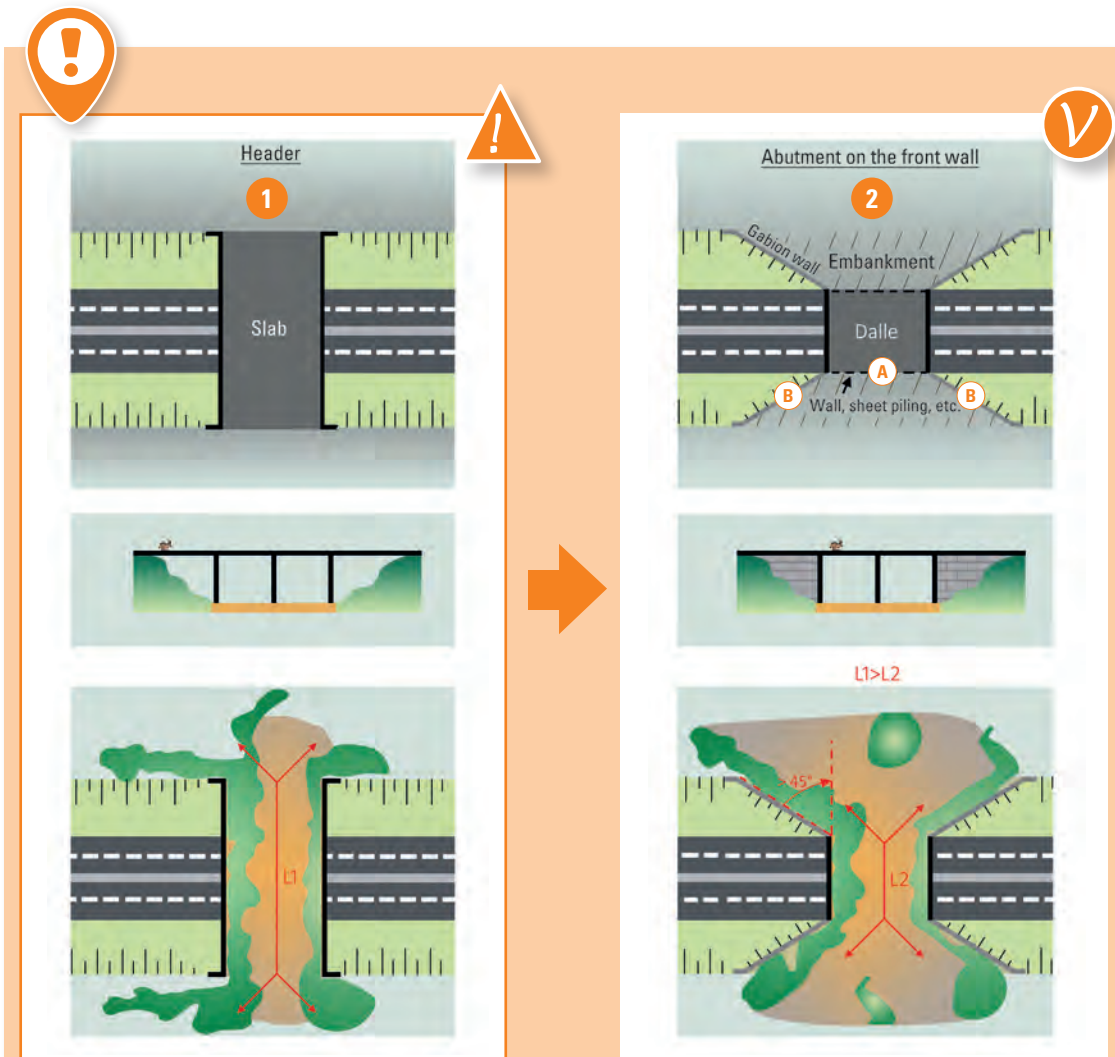

② Schematic representation of a structure without (1) and with (2) abutment in front wall. The length of the crossing is significantly reduced with a structure equipped with an abutment on the front wall. Source: Cerema.

Vegetation development of the deck

■ Structure of vegetation

The advantage of the overpasses is to be able to plant the deck. The objective is then, when possible, to create favourable corridors for each major type of habitat or faunistic species. However, it is not advisable to create a disordered mosaic of environments. It is recommended to create specific corridors for each habitat that crosses the structure, from side to side, connecting them to the habitats that have been separated by the infrastructure. The size of these corridors is determined both according to the available space and the quality of

the desired habitat. Vegetation development must be done early on (before commissioning) in order to be established as quickly as possible (③).



Vegetation development of the passage must be completed as early as possible before commissioning of the infrastructure.

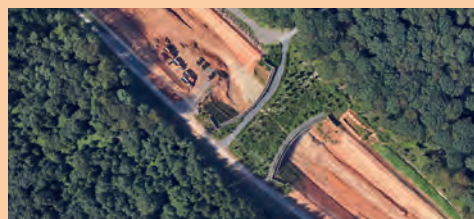

③ Example of a passage in Germany (B50 in Wehlen) that is already functional during the construction phase. Source: Google Earth.

On smaller structures (ordinary all fauna passage), the limited space available reduces the possibilities of habitat diversification. The development can be limited to planting dense shrub hedges on each side, along screening parapets, (4, 5 and 6 next page). These hedges (see "planting hedges and woodland" inserts) ensure the continuity of the planted strips running along fences, or even continuity with the wooded areas crossed. The central space is reserved for a more open area of close-cropped grassland (sowing 10 to 20g/m²) allowing unobstructed views of the entrance to the passage (see "plants of guaranteed local origin" insert). Some additional developments (e.g. swaths*, bushes cut into shrubs, isolated trees,

especially fruit trees) can complete the layout and enhance attractiveness, without however constituting a vegetation mask.



Planted eco-friendly bridge*. Source: © VINCI Autoroutes photograph library – Emmanuel Rondeau.

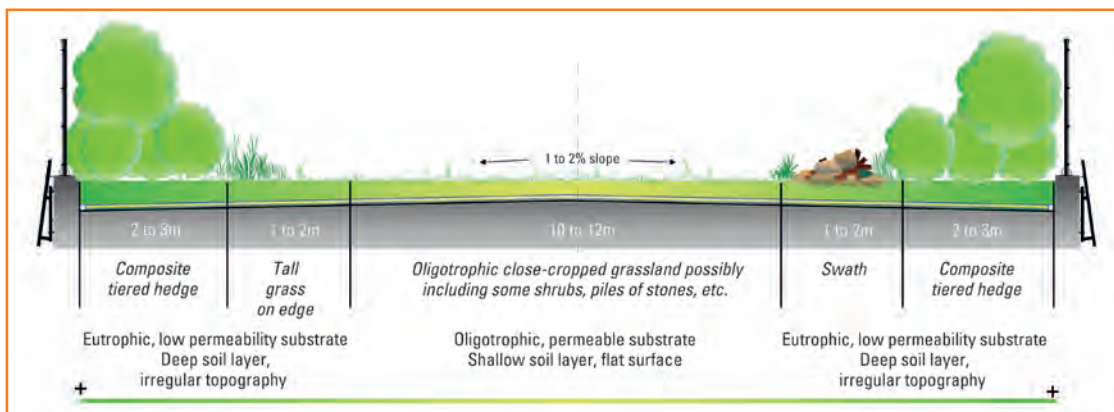

4 Schematic example of the development of an ordinary all fauna passage. Source: Cerema.

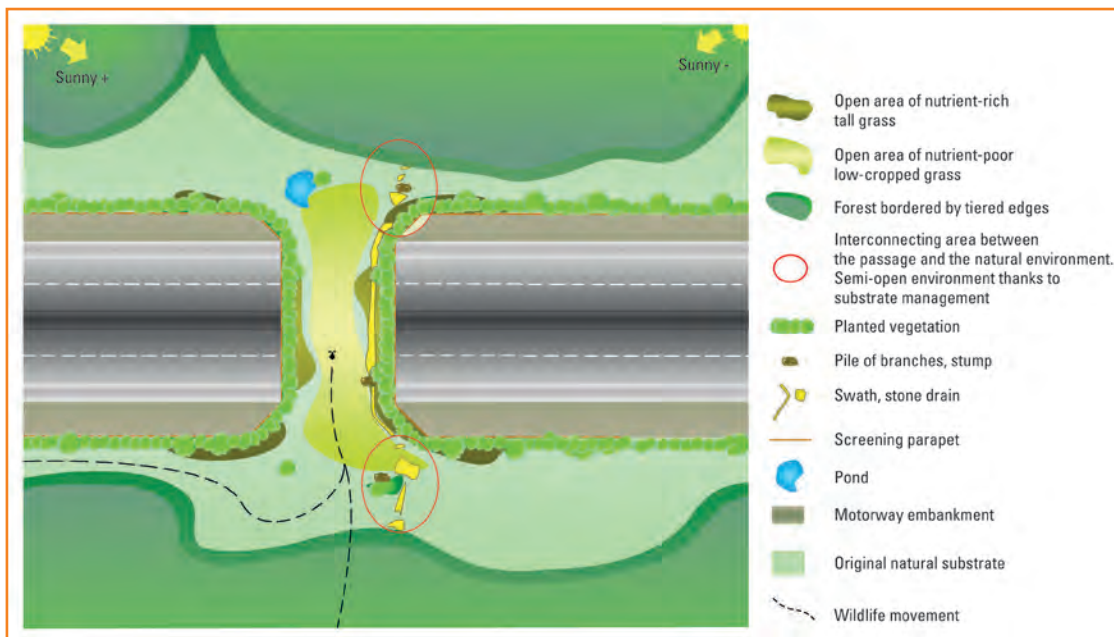

5 Schematic example of the development of an ordinary overpass in a forest context. Source: Cerema.

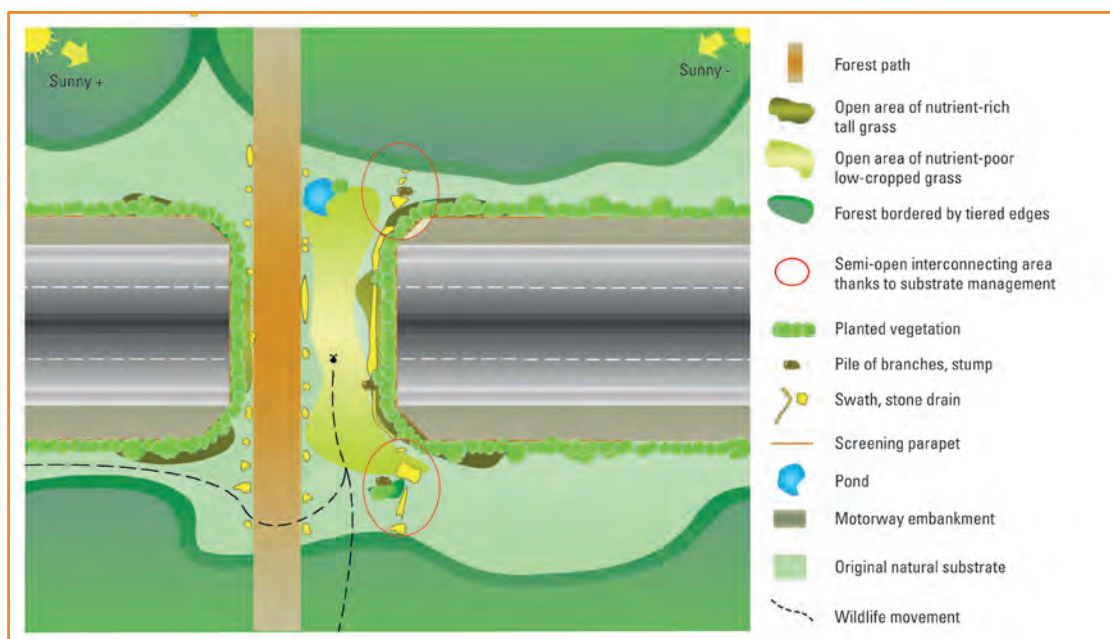

6 Schematic example of the development of an ordinary mixed overpass in a forest context. Source: Cerema.



Planting of hedges and trees

Composition

To ensure a better diversity and sustainability of the landscaped structure, planting should include a mixture of trees and shrubs, ideally 4 to 8 different species, or even more.

The species must be indigenous and adapted to the soil on-site. It is recommended to take inspiration from the species present locally. These plants must be chosen according to the long-term role they are to play. Plants must also be able to survive the conditions to which they will be exposed. They will therefore be chosen according to the depth of the reconstituted soil, the type of substrate and local conditions. The system must also be compatible with frost and sunlight conditions. Finally, the vulnerability of species to climate change may be taken into account.

The choice must also be directed towards a mixture of species that flower and fruit differently and at different times over the year, so as to meet the needs of as many animal species as possible.

Young plants under the age of three should be preferred because they adapt more quickly. For trees that must constitute the tree stratum (essentially at the entrances of the passage and not on the deck), it is advisable to choose saplings* less than 2m high. Individual protection such as a meshed sleeve is necessary, in particular for fruit trees, to avoid grazing and rubbing by deer.

This system is to be completed with a few species that can be pruned down in order to promote dense growth of the wooded area.

.../...

Plant protection

The soil must be covered by a natural and biodegradable mulch (residues from grinding deciduous branches (avoid evergreens) such as oak, beech, maple, etc.) for each row over 1m wide with a thickness of 15 to 20cm of material to protect the plants against competing vegetation, promote the biological activity of the soil, preserve its moisture and moderate the temperature.

If there are large local populations of wild boar, perhaps prefer biodegradable tarpaulins anchored to the ground. Watering devices or manual interventions may be necessary for the plants to become established during the first two or three years.

Planting period

It extends from November to mid-March, taking care to plant outside periods of frost. In the Mediterranean zone, plant in the autumn for better resistance to water stress the following year.

Planting

- For a hedge: arrange the plants in a staggered formation over 2 rows spaced about 1m apart, so that eventually the hedge becomes a sufficiently dense screen, like a tiered edge. Space the plants 50cm apart for plants under 1m tall, 60 to 80cm apart for shrubs 1 to 2m tall, and more than 2.50m apart for trees (planted in the immediate surroundings of the structures and not on the deck where large shrubs will be preferred). The hedge must be planted 1-2m from the fencing or parapet.
- For a wooded area: if the edges can be designed as hedges, the centre of the wood must consist of several lines (4-5) of large shrubs arranged irregularly.

Observation of the successful rooting of plants

Make sure the planting services guarantee rooting of the plants over a two-season period at least.

In the event of replacement at the end of the warranty period, care must be taken to ensure the replacement conditions and to identify the cause of plant mortalities: if the plants have dried out, because they are unsuitable, it will be necessary to change the species.



The price of a hedge on a 1m wide line varies between €10 and 150/lm, depending, among other things, on the size of the plants.

When the passage is wide enough, the development can be more complex. The objective is then to restore a majority of fragmented habitats. Even if there is no precise rule concerning the development, it is recommended to reserve at least 30 to 40% of the width for the space mainly crossed (forest, moorland, etc.). Each other type of habitat can then form strips ranging from 10 to 25% of the space, or even more, depending on the number of environments to be reconnected. In all cases, all open spaces (close-cropped, tall grass, swaths*, etc.) must occupy at least 60% of the width.

While the types of habitat to be reconstituted and their scale vary depending on the context of the passage, vegetation development should usually include (⑦, ⑧ and ⑨ next pages):

- a shrubby wooded area (or even a tree planted area for the largest passages) creating a closed environment, favourable for species that move under a forest cover, like several terrestrial beetles* or small mammals. This space located on a eutrophic* and deep substrate (see "planting hedges and woodland" insert) should be positioned on the side where the sunshine is weakest;

- an open zone on rich, low permeable and uncompacted substrate that promotes the development of tall herbaceous vegetation occupying both edges of the wooded area. This area is ideal for the movement of micro-mammals*, orthoptera*, chiroptera*... The vegetation should be spontaneous or have seeding adapted to the natural and local context (e.g. See "local vegetation and real meadow plant label" insert**). It is simply maintained to prevent the growth of bushes;
- on the sunniest part, a fairly large expanse of oligotrophic meadow* where grass (spontaneous vegetation or seeding adapted to the natural and local context) grows on poor soil compacted and permeable to varying degrees. These environments are often used by mammals, amphibians, reptiles and many insects. Within the space constituted in this way, depending on its width, a few units of shrub vegetation in bunched formation can be added to reinforce peaceful zones on the passage.

These small entities then require a very local increase in the height of the substrate (e.g. earth mound).

Vegetation development is complemented by the establishment of secondary habitats, so as to promote the reception and passage of as many species as possible (see next chapter).

While the connection between the habitats located on either side of the structure is sought, it is nevertheless necessary to ensure that these developments do not create a barrier at crossing points between the different networks of habitats, especially at the end of the structure. In particular, dense forest areas or swath* structures can constitute significant obstacles* for terrestrial species not dependent on these environments. Particular attention must therefore be paid to these junction points. A mosaic of overlapping habitats will therefore be preferred to the creation of monospecific corridors (see diagrams 5, 6, 8 and 9).



Plants of guaranteed local origin

As part of a partnership, the network of French national botanic conservatories, Plante et Cité and Afac-Agroforestry, have developed an approach to promote the production of plants or trees adapted to specific territories, by creating the "Végétal local" and "Vraies messicoles" labels. The objective is to provide wild plants of guaranteed local origin. The seeds are taken from the natural environment of each locality (11 biogeographical regions independent of the administrative regions have been defined as the regulatory framework of the brand) and have thus preserved maximum genetic diversity guaranteeing the plants good short- and long-term adaptation. Plants are suitable for ecological restoration or any other development whose objective is the conservation of biodiversity* (green and blue grid*, management of invasive alien species, etc.).

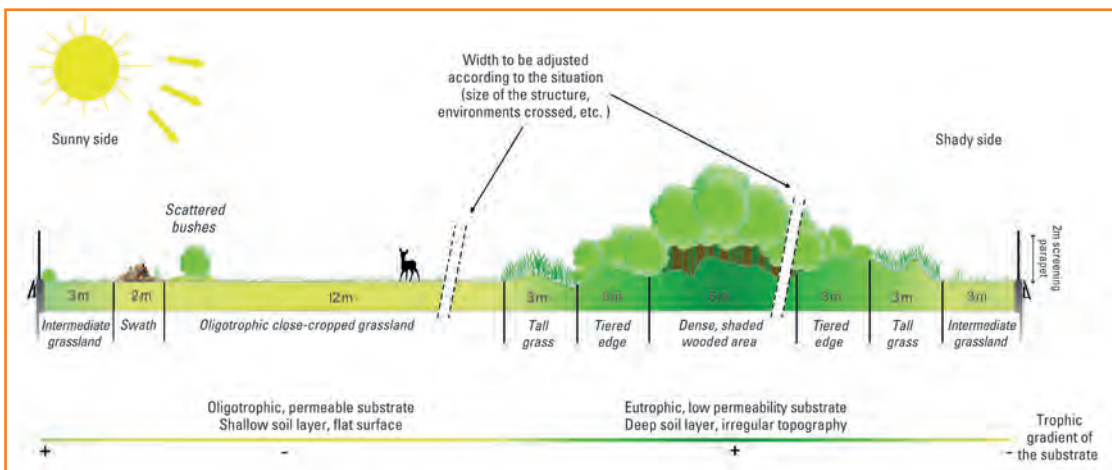

7 Schematic example of the development of a remarkable passage in a forest context. Source: Cerema, according to BN Federal agency for Nature conservation, 2019.

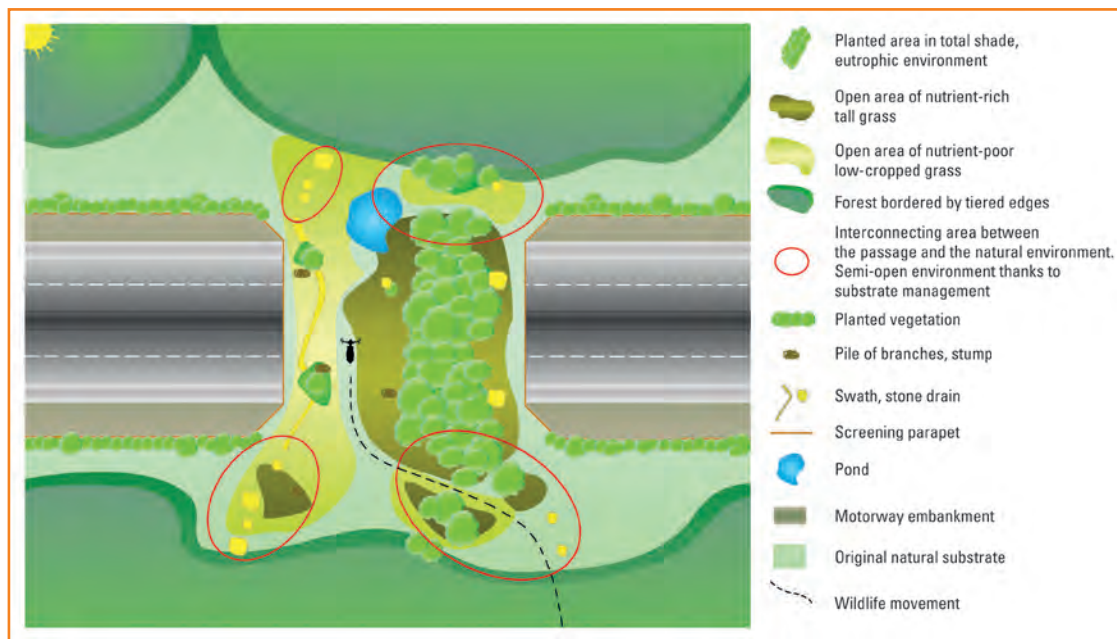

⑧ Schematic example of the development of a remarkable passage in a forest context. Source: Cerema, according to BN Federal agency for Nature conservation, 2019.

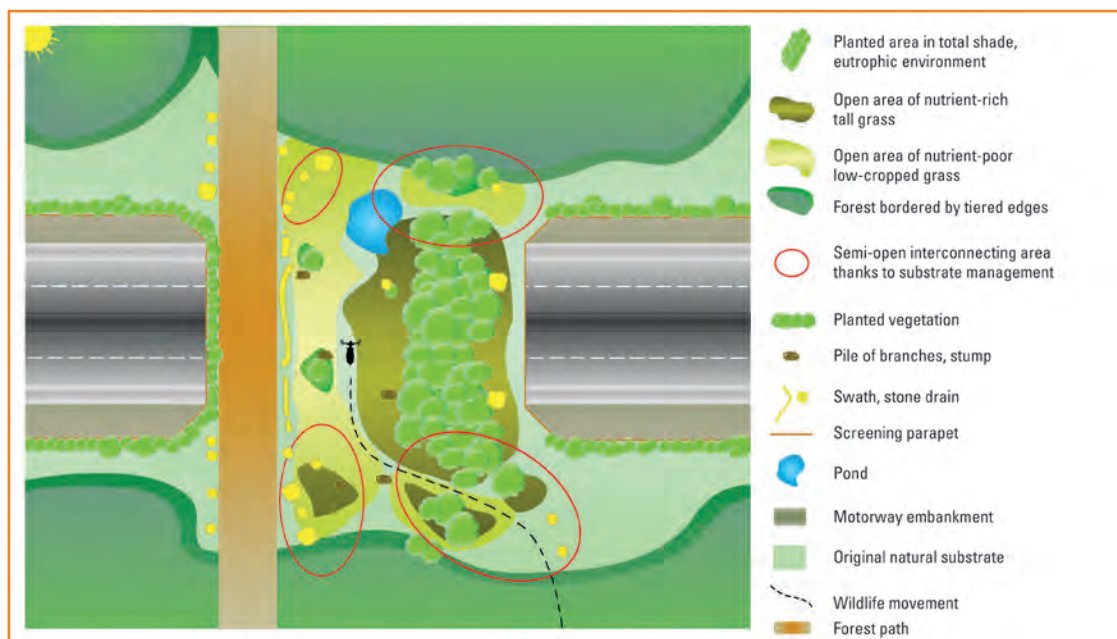

⑨ Schematic example of the development of a remarkable mixed passage in a forest context. Source: Cerema.

■ Soil structure

The planting of the deck of the fauna passage requires a series of layers of materials chosen according to the characteristics of the desired vegetation, the climate and the characteristics of the structure.

These systems must both allow the supply of water to plants and therefore their development, while ensuring soil drainage and protection against root penetration.

From the surface, the following must be distinguished (⑩):

- **the vegetation layer:**

- substrate: topsoil rich in nutrients, low permeability, on areas hosting woodland or tall grass.

Alone or mixed with sand or gravelly sand (0-6mm) and low in nutrients, to form more oligotrophic areas*. This substrate can be locally compacted (always linearly in the direction of crossing), in order to increase the diversity and creation of micro-habitats within the area. Also make sure to adapt the nature of the earth to that of the surrounding environments, in particular the pH and the rate, or even the absence, of limestone, which directly condition floral species and therefore fauna (especially insects) that will use the structure (in siliceous zones, prohibit soil with active Ca and swaths* or limestone rockfill).

In areas hosting woodland or tall grass habitats, it is worth establishing an irregular soil microtopography in order to increase the range of micro-conditions and therefore of micro-habitats. Conversely, closely-cropped grass areas can remain flat for easy maintenance (possible mowing),

- thickness: 20-30cm to 1.5m depending on the choice of vegetation required and the local climatic context. Planting requires a minimum thickness of 20-30cm for herbaceous seedlings and it is not recommended to go beyond 90cm if you want to limit the size of the woodland and the weight to be supported by the structure. The thickness of soil is thus generally 30cm on most of the structure and the thickest sections (60-90cm) are reserved for areas hosting shrub environments (for a shrub structure, 60cm of soil is usually sufficient, but 90cm is sometimes preferable in areas where the average annual rainfall is less than 500mm).

On larger structures, when tree planting is possible and required, the soil thickness can be increased to 1.5m;

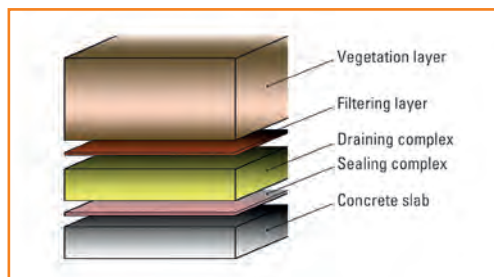

⑩ Schematic section of the different layers of material on a planted passage. Source: Cerema.

- **the filtering layer:** this is an anti-contaminant geotextile designed to let water penetrate while retaining fine particles of the vegetation layer;



Sealing and drainage phase of the deck. Source: Vinci Autoroutes/ASF network.

- **the draining complex:** the draining complex must be designed to direct water towards drains and avoid excessive build-up in the substrate. The drainage system most often corresponds to a 5 to 10cm bed of draining pebbles between two layers of geotextile. This complex is associated with drains located on each side of the structure to allow water to be evacuated from the development;

- **the sealing complex,** which, on concrete structures, usually comprises a layer of gravelled asphalt a few centimetres thick (possibly with a bituminous strip previously glued to the slab), protects the structure while sealing it and acting as a root barrier.

While seepage water in the soil is discharged through the draining complex, surface water run-off requires:

- gently sloping land (2-3%) on the structure from its longitudinal axis to the sides,
- an overall slope of 2 to 3% from the centre of the structure towards the entrances if there is a double slope or > 1% if it is a single slope.

The water evacuated can be used to supply water points (see ponds*).



APRR is currently conducting experiments to lighten the structure of the surface layer of fauna passages, in order to reduce the loads to be taken into account for their sizing. The experimental surface layers used (lightened with and without a honeycomb HDPE or wood reinforcement structure, "garden" roof) were chosen according to several criteria: having a sufficient water reserve to allow good development of vegetation, resisting trampling caused by the passage of animals and possible scouring (badgers, wild boar), being durable and being as light as possible.



Example of the Ville-sous-la-Ferté fauna passage (A5).
Source: Cerema.

These developments are accompanied by both a monitoring of the evolution and the quality of the vegetation and monitoring of the use of the passage by fauna before and after developments (in progress), in order to evaluate ownership of the structure by the animals.

Development of additional habitats on the deck

■ Swaths*

A swath corresponds to a more or less continuous linear structure 1 to 2m wide, 0.7 to 1m high, consisting of a cluster of different natural materials:

- blocks (Ø 20 to 80cm) with two size categories to create heterogeneity, 70% of 20-40cm blocks and 30% of 40-80cm blocks;
- low rotting stumps or logs (Ø < 10cm)... preferably chestnut, oak, larch, black locust, etc.

These materials must be more or less mixed and arranged lengthwise, from one end of the structure to the other.

The objective of these constructions is to offer maximum shelter to all small species (micro-mammals*, insects, reptiles, etc.). They make it possible both to constitute living environments and create safe spaces when crossing the structures. In the long term, these are micro-corridors that improve the attractiveness of the passage and form a more or less continuous structuring network, which crosses the passage and extends through to the continuities interrupted by the infrastructure.



Schematic diagram of a swath. Source: Cerema

These swaths offer contrasting situations in terms of temperature and humidity, suitable for a range of species.

On overpasses, they are installed along the screening parapet or along woodland areas. To promote the attractiveness for reptiles, it is better to position them on the side offering maximum sunshine. In order to prevent the swath from constituting a longitudinal barrier for wildlife, it is sometimes preferable to make a discontinuous structure (see photograph ①) to avoid partitioning the area and facilitate free movement over the entire width of the passage.



① Discontinuous swath on a Spanish passage.
Source: Minuartia.

On mixed structures associated with a path, they can also be used to separate uses, by constituting an obstacle between the area reserved for wildlife and the path.

To avoid theft and the disposal of materials on the motorway, it is possible to cover the swath* with large-meshed fencing (10-15cm) and anchor it firmly to the ground (12). Some motorway management authorities also recommend connecting wooden logs with a steel cable anchored to the structure.



12 Fenced swath to avoid theft and the disposal of objects on the motorway. Source: Vinci Autoroutes.



In most cases, all or part of the materials can be recovered on or near the site. Machinery is usually on site, which limits the cost of producing a swath. In the absence of these facilities, it is necessary to count between €80 and 150 excluding VAT/m².



18 years of evolution of a swath* made of wood and rocks, A28 Pr77,5 Vinci Motorways/ASF Network – OGE V. Vignon

This dedicated 12m wide passage was equipped with a wood and rock swath in 2000. In the aerial photograph on the right, the tracks of large fauna that use this passage (wild boar, roe deer, deer) can be seen distinctly on either side of the swath.

Detailed view of the swath 5 years after its construction: a hedge is growing, notably thanks to the seeds brought by birds that land on the structure. Heather* moor is growing back on the edges. The swath is gradually "going back to nature". The structure is particularly favourable for ground beetles*, reptiles, and micro-mammals*.

Detailed view of the swath, 18 years after its construction: the screens have been painted brown. The hedge, the young trees and the bushy stratum have developed. The latter has been managed by grinding.

Of the original swath, only the discontinuous rock structure remains. The wood has disappeared except for large pieces more than 50cm in diameter (the big stump highlighted by the yellow arrows is the only piece of wood that has barely changed).

The hedge that replaced the wood plays its functional role for wildlife on the structure. Vegetation management allows a mosaic of natural habitats to be maintained on the structure and along the swath.



■ Wall and low walls

Simple drystone walls 70 to 80cm high (13), or even gabion walls* (14), can be envisaged. They are particularly appreciated by reptiles, because they help their thermoregulation. In order to be attractive, care must be taken, among other things, to orient the structure according to



13 Dry stone wall. A8 motorway.
Source: Jean Carsignol.



14 Gabion wall on a German passage.
Source: Christine Henn, Mobil Hessen.

exposure to the sun and other features likely to limit sunshine (parapets, vegetation). It is also possible to construct or arrange the structures specifically to multiply microhabitats, so as to create favourable environments according to the time of day (e.g., curving the walls).

Low walls may also constitute support structures for:

- laying locations or *hibernaculum**, or both, at the back of walls (see "Development of immediate surroundings/*hibernaculum*" (29 30 31) and sheet no. 20);
- earth retentions, to have local access to sufficient substrate height for planting while reducing the road coverage. These are particularly interesting developments on structures:
 - small dimensions, as these structures can, for example, help create lateral vegetation corridors while maintaining a grassy area at the centre of the structure without overloading it (avoids the need for thick cover over the whole deck width),
 - during the summer drought in a Mediterranean climate when the water reserve is directly linked to the height of the topsoil.



In Germany an eco-friendly bridge* has benefited from the implementation of a gabion wall over the entire crossing of the passage. Distribution monitoring carried out on the lizards on and around the structure (cumulative results, 2011) showed that:

- adults and juveniles were observed predominantly south of the gabion wall* (sunny side);
- conversely, and contrary to green rights-of-way, on the remainder of the central part of the structure where habitats are not very structured in terms of vegetation and are less exposed to the light, there have been very few sightings.

The orientation of the environments and the resulting characteristics can thus play a role in the operation and use of habitats reconstructed on the structure.



Location of lizard sighting points on and around the structure.

■ Pile of stones or branches

Like swaths*, simple piles of stones, branches (15 next page), or even trunks, can vary the availability of habitats. These piles of branches can also promote

the installation and spontaneous development of bushes. They must also be taken into account during development and appropriate management and maintenance measures must be scheduled in order to ensure the sustainability of these developments.



19 Development of a cluster of branches in the works phase and its evolution two years later. RD64 (70). Source: Jean-Paul Chatel. DIR Est.



Eco-terrace* for an eco-friendly bridge* designed by the X-Aequo agency for Vinci Autoroutes combining:

- blocks of honeycomb terracotta brick, lightening the weight of the structure and providing porosity for wildlife;
- occasional piles of rotting logs in the body of the low wall which protrude from the façade to diversify habitats;
- unbonded rock block façades creating gaps for wildlife, integrating them into the structure and stabilising it;
- massive occasional stumps at the head of the module to diversify habitats;
- manual stone finishes and wedges;
- rocky roofing slabs;
- a bed of crushed stone for drainage and wedging behind the blocks, to ensure the stability of the structure and a porosity gradient for the fauna at the bottom of the wall;
- topsoil (about 80cm high) behind the ballast with an organic material-amended surface layer (compost) to plant saplings*;
- gentle slopes at the beginning and end of the modules to ensure routing between the axial area of the eco-friendly bridge*, the foot of the terrace* and the wooded mound at the rear;
- a variety of different soil and exposure possibilities (deep/shallow soil, earth/rocky areas, gentle/steep slopes, north-south-facing, well or poorly drained substrate depending on the internal presence of ballast, etc.) ;
- a discontinuous arrangement, each module being 5 to 7m long and allowing transversal paths between the centre of the structure and the edge of the screens.



Implementation of "series" of eco-terraces A8 and A57 motorways. Source: C. Buton, Cabinet X-Aequo.

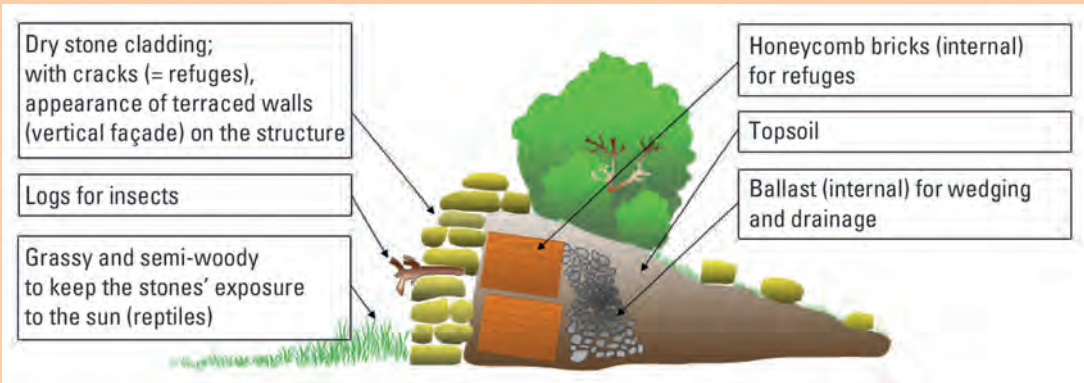

Systems ensuring the tranquillity of the crossing

■ Screening parapet

Each side of the structures must be equipped with an opaque screening parapet (16), in order to reduce nuisance related to noise, the movement of vehicles on the infrastructure crossed and the glare of the headlights at night.

The system must be installed over the entire crossing of the structure and on each side, in order to constitute a passageway and continue around the passage (see development of immediate surroundings).



16 Screen of the La Buisse fauna passage (A48 – Réseau APRR), made in non-chemically treated locust tree. The wood was removed locally from motorway rights-of-way and processed nearby (sawing and panel manufacturing). In order to determine the strength class of this wood for sizing the panels, a selection of boards was subjected to bending tests. Source: APRR.



Characteristics of screening parapets

- **Dimension:** 2 to 2.5m high.
- **Materials:** panels can be very varied in nature, but slatted or wooden panel structures are recommended for better insertion. The cross section of the wooden elements must be large enough (> 22mm for exotic wood and > 30-35mm for local species) to avoid deformation (minimum dimension excluding wind calculation).

To minimise maintenance, wooden elements are naturally resistant or have a durability conferred by a treatment corresponding to:

- use class 3 (according to standard NF EN 335 of May 2013) if there is a certain absence of prolonged humidification and sufficient distance from the ground (e.g. concrete sill);
- or class 4 due to the possibility of the build-up of moisture (contact with the ground, vegetation, etc.).

Local species (naturally class 3) such as oak, larch, chestnut or acacia should be preferred (but need to be above ground).

- **Finishing:** the wood is left whenever possible untreated, which allows natural ageing of the facings and does not require maintenance. A stained or anti-graffiti finish is possible but is not recommended. Screen treatments that could impact saproxylic * species should also be avoided.

- **Laying:** the slats are laid vertically, if possible, to eliminate the risk of water stagnation on the constituent materials (wood, steel, etc.) and the slats are not perforated. If they are (for a lesser wind factor), they must be oriented in such a way as to maintain their role as a visual screen for wildlife.

Signs must also be equipped with a crown or coping (identical wood, aluminium or galvanised) to avoid the risk of stagnation and water penetration at the top ridge of the sign.

- **Assembly components** (dowels, bolts, spikes, etc.): they must also meet corrosion protection specifications.

CROSS-SECTION DETAIL OF A SCREENING FENCE WITH A SYSTEM OF OPEN-WORKED WOODEN SLATS

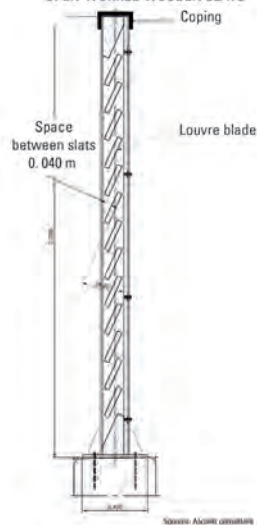

■ **Anti-intrusion/separation system**

In order to deter humans from using the structure as much as possible and in particular with motor vehicles, devices may be installed at entrances to the structures. However, these devices must not create obstacles* to the passage of wildlife and must be reserved for structures potentially most frequented by humans. Some of them can also be used to separate uses, avoid or limit the passage of vehicles.

- Stone blocks > 80cm in diameter, aligned and spaced 1m apart, either at the entrance of the structures or to separate functions (17).



17 Stone blocks positioned along a forest restoration of the LGV Est Européen high speed train line. Source: Cerema.

€ It costs around €30 to 50 per tonne.

- Traffic and awareness signs.



Prohibition sign at the entrance of a fauna crossing. Source: Cerema.

€ Prices vary depending on model and quality but range from €200 to 400.

- Grazing fences.

- Ditches, holes, stumps, stone walls: their objective is to make it difficult for vehicles to cross the structure.

- Chicane barriers (patented ESCOTA/Cabinet X-Aequo system): they prevent practically all vehicles from crossing (18) without creating a real obstacle for wildlife (19).



18 Chicane system installed on the A57 motorway overpass. Source: Jean Carsignol.



19 Ungulates passing through the chicanes of the passage. Source: X-Aequo.

€ This type of system costs around €100 to 200/lm.

- Metal or wooden posts aligned and spaced 1m apart at the entrance to the structures. While they do not stop motorcycles, they prevent the passage of 4-wheeled vehicles.

- Barriers



Wooden gates installed along the path to prevent vehicles from accessing the wildlife area. Source: Cerema.

€ A wooden barrier costs around €100 and 400/lm.

Development of underpasses

Reduction of the crossing length

■ “Wing” retaining walls

The purpose of these walls is to support the side embankments at the exit of the structure and to increase the space available for wildlife while reducing the length of the crossing (④ and ②). This system makes it possible to limit the sometimes deterrent corridor effect for certain species or individuals of species. The opening angle of the walls must be greater than 45°.



④ Bois de Vigneule underpass fitted with “wing” walls. LGV Est européenne. Source: Néomys.

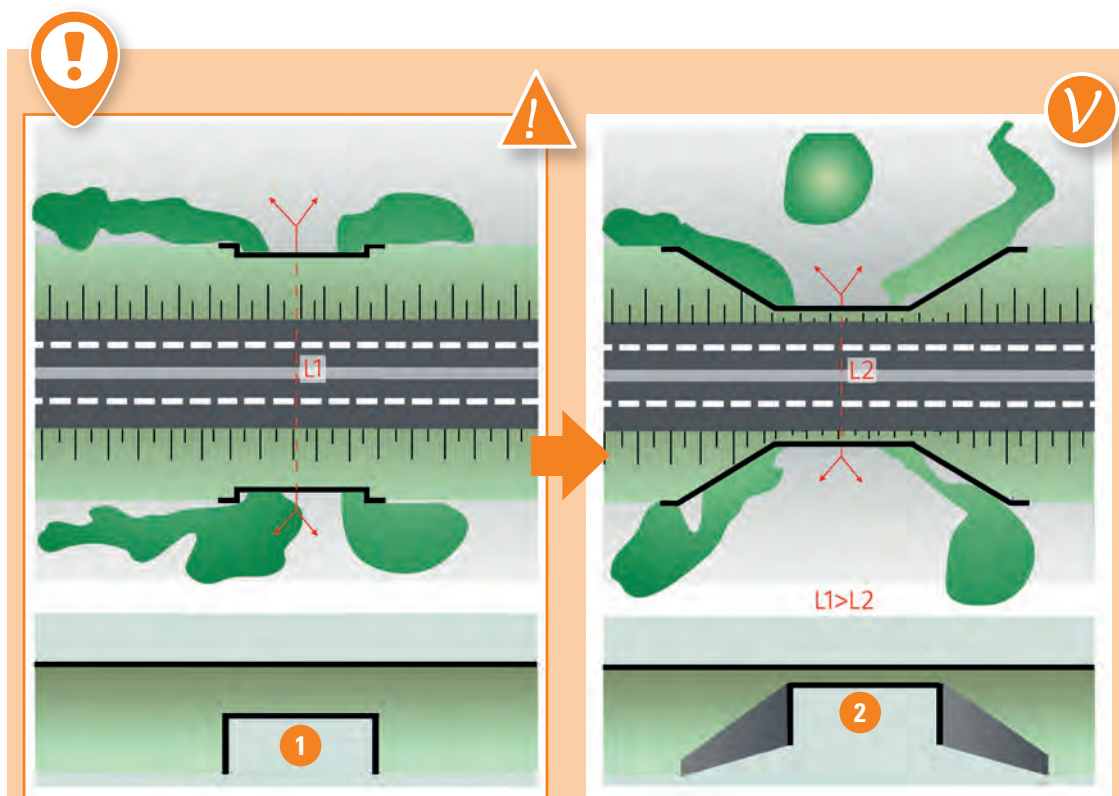

② Schematic representation of a structure without (1) and with (2) “wing” retaining walls. The length of the crossing is reduced when it is built on a structure. Source: Cerema.

■ Structure of equivalent height at the embankment level

Although generally a little more expensive, this should be the preferred solution when the height of the embankment is moderate. This solution also has the advantage of increasing light intensity under the structure and of decreasing the tunnel effect (22 and 23).



22 Underpass of equivalent height to the embankment. RN 4 (54). Source: Cerema.

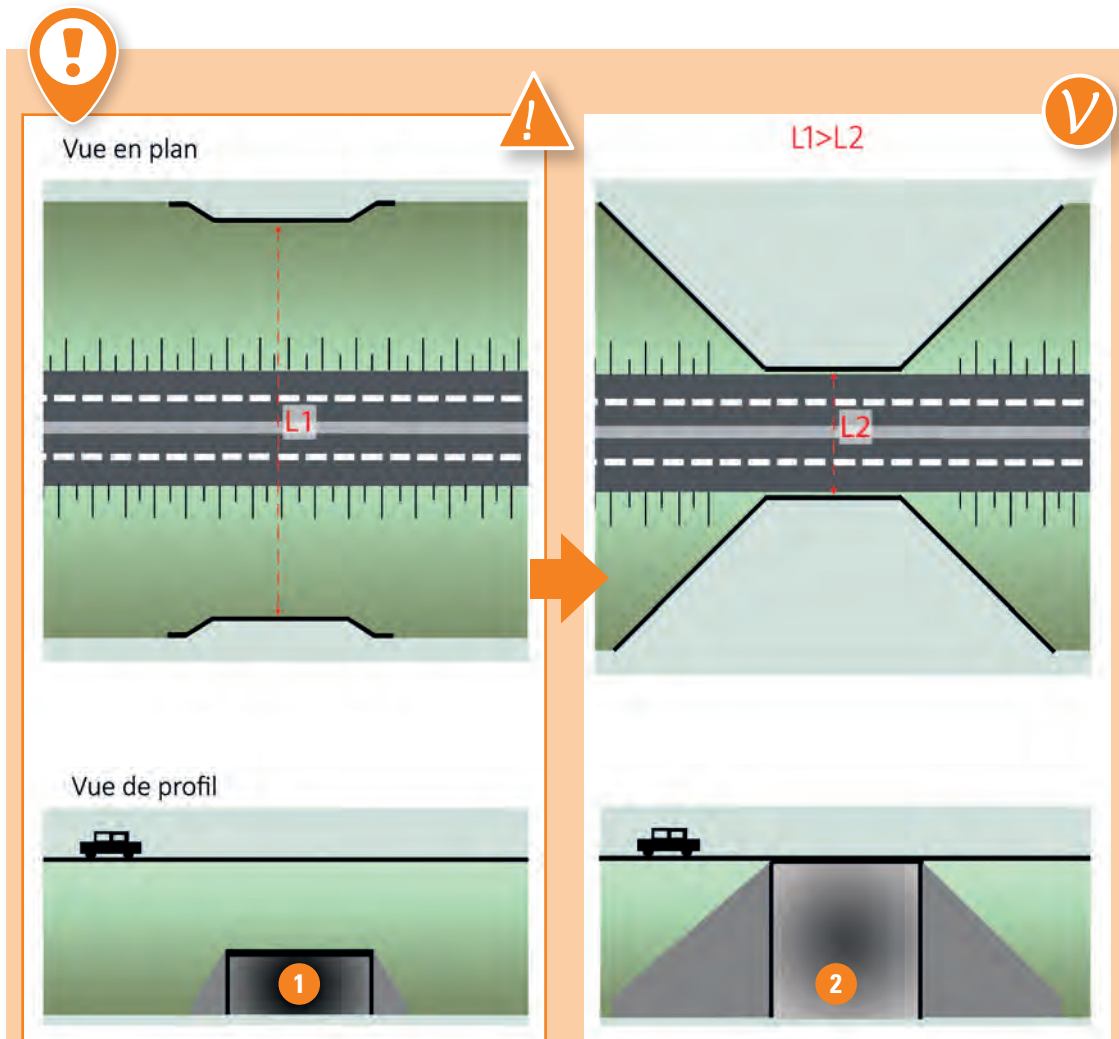

23 Schematic representation of a passage with an embankment above the deck (1) and a structure of equivalent height to the embankment (2). Source: Cerema.

■ Layout of the structure at the top of the embankment

When the structure is mixed, however, the connection of the restoration path may prove to be a little more technically complex.



Underpass positioned at the top of the embankment. Source: Cerema.

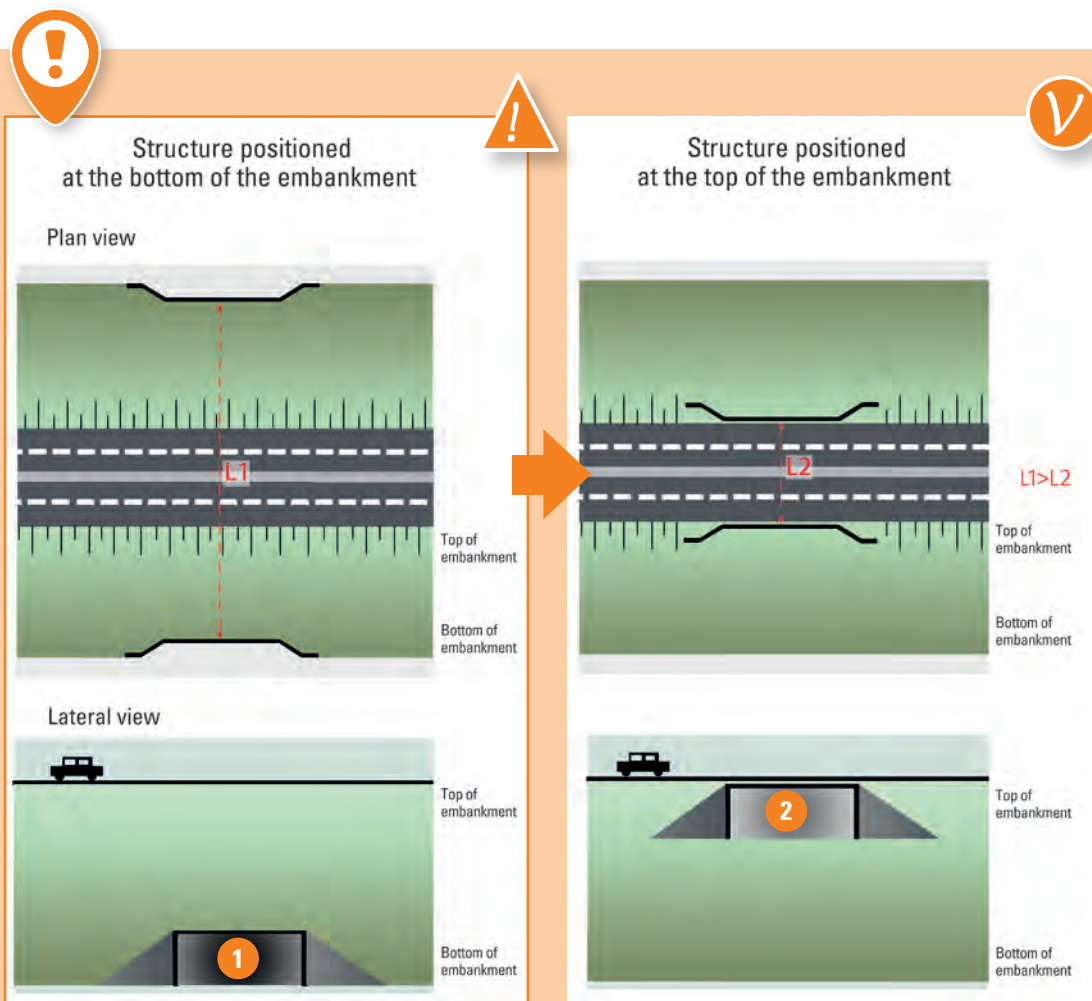

Schematic representation of a passage with an embankment above the deck (1) and a structure of equivalent height to the embankment (2). Source: Cerema.

Construction of a vertical support structure

This structure (24 and 25) (gabion*, concrete wall, etc.) should be built above the construction head to retain the embankment.



24 Olzey stream structure. RN 59 (54). Source: Cerema.

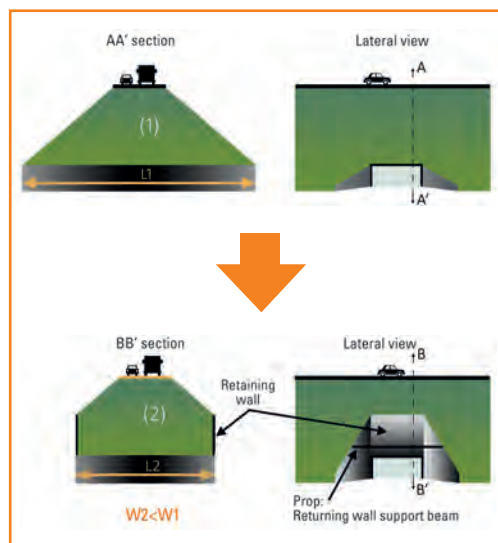

25 Schematic representation of a passageway equipped with a vertical retaining wall above the construction head (2) and an unequipped passageway (1). Source: Cerema.

Vegetation development of underpasses

For underpasses, the planting possibilities are more limited and vary according to the characteristics of the passage:

- for the smallest structures where vegetation is difficult, priority must be given to the size of the structure so that may be as high as possible, in order to promote its vegetation and so that as many herbaceous plants as possible can grow up to the centre of the structure. For these structures, it is not recommended to plant inside the passage, but to allow the vegetation to settle spontaneously. However, plantations may be considered at the entrances to connect the structure to the separate habitats, but care must be taken not to obstruct the entrance to the passage, so as not to limit the light intensity inside the passage. Additional swath-type structures (see next chapter) can also be very useful in complementing the development;
- for very large underpasses (commonly referred to as viaducts), the objective here must be the conservation of existing habitats and in particular strips of vegetation. Should the work require the destruction of habitats, development must focus on reconstructing degraded environments or improving connectivity. In the latter case, depending on the context, the development recommendations proposed for the upper structures may be repeated.



Colonisation of underpasses by vegetation. Cerema, 2018

A study carried out by Cerema on the colonisation of underpasses by vegetation (10 structures with sections ranging from 16 to 120m²) shows that for a length of 20 to 30m, a section (width X height) of 60m² allows vegetation to cover more than 25% of the entire structure.

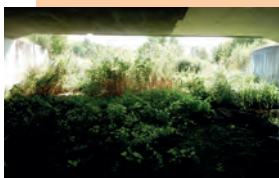

Underpass. RN59 (Grand Est region). Source: Cerema.

Development of additional habitats in the structure

■ Swaths* or clusters of branches

Like overpasses (see "Development of overpasses – Development of additional habitats"), swaths or clusters of branches can be used in underpasses. In general, on smaller structures, they are placed along the abutment or pillars of the structure, but on large structures, they may be less off-centre.



Underpass with swath. RN67 (52). Source: Cerema.

System ensuring the tranquillity of fauna

■ Anti-intrusion/separation system

In underpasses, the separation of structures may be carried out by systems similar to overpasses, but in this category of structures, it is also possible to use the presence of watercourses to provide this separation.



Underpass in which uses are separated by blocks and the passage of a watercourse (A34 motorway). Source: Cerema.

Development of immediate surroundings

Securing a sufficient surface area at the entrance to the passage

The overall objective of fauna passages is to restore the ecological network at a given point for as many faunistic series as possible. It is therefore necessary to offer optimal conditions for the passage of these species, that is to say offer them conditions which are close to their living habitat or at least favourable to their movement. Particular care must therefore be taken with the layout of the structure, its direct surroundings and the conditions for connection to neighbouring landscape structures.

To achieve a coherent layout, it is first of all recommended to have a sufficient development area on each side of the passage (of around 2,500m² for ordinary structures, 5,000m² ²⁶, or even up to 1ha for exceptional structures). However, it is up to the contracting authority to define precisely the size of this area so that the structure is as efficient as possible according to the category of passage, the topography of the site, the surrounding environment and in particular connectivity with habitats. This coverage surface must, if possible, be integrated as early as possible into the process, that is to say from the design phases of the project and in particular when defining coverage areas.

If this area is not integrated into the coverage itself, the manager is however invited to ensure its control (acquisition or management). In order to conserve this surface over time, it is, for example, advisable to classify it as an N zone that cannot be built/developed when the urban planning document is updated. This area may also be included in the definition of compensatory measures ²⁷ next page).

It is also possible to implement a real environmental obligation (ORE) to sustain the ecological purpose of the surrounding areas of the passage. This system created by the Act for the recovery of biodiversity*, nature and landscapes constitutes a new legal mechanism, allowing landowners to create environmental protection obligations on their land which last for the entire duration of the contract (up to 99 years), regardless of any changes in ownership of the property. The sustainability of the measures implemented is thereby guaranteed.

The design of the structure and its surrounding area will depend on the size of the passage and in particular on the space available for wildlife, the diversity of habitats crossed that will need to be restored and the type of structure (underpass or overpass).

It should be noted that the cost of these environmental planning provisions is minimal compared to the cost of construction of the structure, while it very strongly determines the efficiency of the investment.

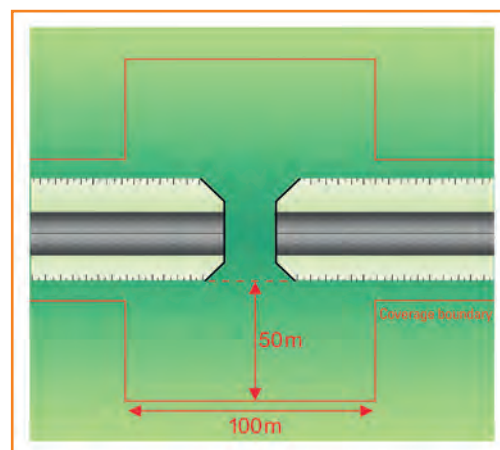

²⁶ Schematic example of a development area of 5,000m² to be reserved around an all fauna passage. Source: Cerema.



Even if the average cost of agricultural land varies greatly from region to region (from €2,000 to more than €10,000/ha for grassland or arable land), the cost of acquiring a surface area of 2,500m² for each entrance of a structure remains minimal compared to the whole infrastructure project. Even at a price of €10,000/ha, the purchase cost for 2,500m² at each entrance will be around €5,000 for a structure.



27 Compensatory measure in the surrounding area of the fauna passage. Extension of the A16 motorway on the SANEF network. Source: Geoportail.

Vegetation development and diversification of habitats

In the case of overpasses and underpasses, it is first recommended to plant along the fences to the structure's entrances. The objective is to build a dense strip of vegetation that will help improve tranquillity (masking the traffic from the upper structures), make the surroundings of the passage more natural and guide wildlife coming from the side into the structure. A mixture of woody and shrubby species makes it possible to obtain the desired dense afforestation.

The length of the sections to be developed depends on the context of the structure but a

minimum of 30m on either side of each entrance is recommended. Care must be taken to ensure that the installation of this strip does not interfere with the maintenance of the fencing.

In underpasses, the vegetation must not obstruct the entrance of the passage or reduce the light intensity inside the structure.

To this first line of vegetation, when the coverage is large enough, it is possible to add on either side of the entrances a second, looser line of vegetation along the coverage, in order to constitute a guiding corridor to the passage (28).

The rest of the development will focus, where possible, on reconnecting habitats broken by the infrastructure. The main task for overpasses will be to extend the reconstituted habitats on the deck to the habitats still in place.

In all cases, for overpasses and underpasses, it will be necessary to try to create an attractive refuge area for wildlife, by diversifying habitats, connected to the potentially present species.

If low walls, piles of stones or branches can be built in these coverages (see "Development of overpasses"), they are also preferential places to develop a larger surface area whether requiring deeper excavation of the ground (*hibernaculum**, pond, etc.) or not.

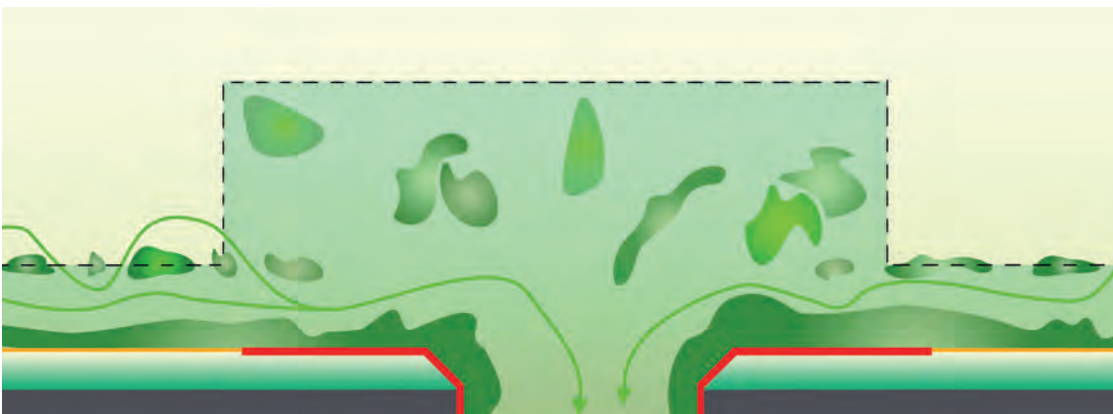

28 Schematic diagram of a double strip of vegetation along the infrastructure to the entrance of the fauna passage. Source: Cerema.

■ *Hibernaculum*

The *hibernaculum* is an artificial shelter where reptiles spend the winter. It can also be a nesting, hunting or refuge area for the rest of the year. These structures may be buried, semi-buried, or form a heap (29, 30 and 31).

In each case, it is a stack of inert and coarse materials, with the gaps and cavities in it acting as a shelter to wildlife. These materials consist of rubble, blocks, branches, cellular bricks, etc.

They are then covered with plants or a geotextile and soil. However, the core of the structure must remain accessible through small open gaps.

Finally, in order to make the site more reptile-friendly, a grassy edge will have to be conserved or developed as close as possible to the *hibernacula*. (see also fact sheet no. 20)



The cost of a *hibernaculum* is around €4,000 to 6,000.



29 Egg laying site / artificial hibernaculum in development. Source: X. Bonnet.

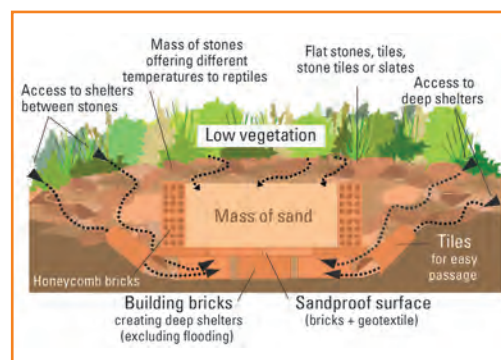

30 Example of a multifunctional shelter for reptiles. Source: drawing by C. Houel, based on D. Guerineau.



31 Hibernaculum. Source: Cerema.

■ Ponds

The presence of ponds near the entrances to the passages makes it possible to provide a habitat for certain aquatic species (amphibians, odonates, molluscs, etc.). They are also frequented by many other species that regularly come to drink (e.g. mammals), hunt, etc.

By placing them at the entrance of the structures (32 next page), they also have the advantage of facilitating exchanges and movements between environments located on either side of the infrastructure.

The size of the pond depends on the available space and the configuration of the site. If it is

dug outside the passage, a size of 5 to 10m² with a depth of 1m and gently sloping banks produce an attractive and sufficiently sustainable environment during the summer.

However, it needs to be sufficiently supplied with water, either by raising the water table or by benefiting from surface flows. In the latter case, certain developments may favour its supply and maintenance in water:

- ensuring that it is the outlet for side ditches (clean water), low point of natural or modelled ground, drain outlet (e.g. drain of an overpass deck);
- sealing the bottom by laying a sealing complex consisting of a first layer of anti-puncture geotextile (surface mass of 300g/m²) topped by a 10/10th of mm thick polypropylene geomembrane and finishing with a second geotextile

layer (the same as the first). This sealing layer can also be extended, in order to improve the water supply by increasing the collected surface area.

The use of clay can also be considered, but it is only effective in the long term on soil that already has a minimum clay content. On more permeable soils (sand, limestone), a thick layer of clay (50-70cm) may however be considered without guaranteeing long-term sealing.

The bottom of the pond is covered with a quality and quantity of materials which depend on the desired species (most often 10-20cm of topsoil).

Wet compacted ponds or depressions can also be built on the deck of the upper structures, but their depth is then limited and constitutes, in most cases, temporary environments.



☺ All fauna passage equipped with a pond at each entrance of the passage. A2 motorway north of Eindhoven. Source: Luchtfoto Irvin Van Hemert – Netherlands.

Ensuring tranquillity of access to the surrounding area

■ Extension of screening parapets

In order to ensure tranquillity in the areas surrounding the passage, the parapet must be extended by 30m on each side of each entrance (33). However, the precise length must be defined according to the implementation context. Also be careful to carefully connect the parapets to the fences.

■ Creation of earth mounds at the entrances of the passage

The infrastructure and vehicle traffic can sometimes be visible when approaching the passage (especially when the structure is located below the natural ground level) and make the passage less attractive to wildlife. To reduce disturbances and guide wildlife towards the entrance of the passage, the spaces next to the structure (34) are modelled and, in particular, earth mounds are created to conceal any elements that could disturb wildlife (equipment, urban zone, etc.) and even the infrastructure itself. This, however, requires control of the necessary coverage. In the latter case, care should be taken to install fencing at the top of the earth mound.

■ Limits on hunting

To establish the tranquillity of the passage and ensure that animals do not associate the structure with a danger, hunting must be avoided within a radius of 200 to 500m depending on the category of the structures (200m for ordinary structures and up to 500m for structures over 40m. These arrangements must be discussed with local hunting organisations and environment managers (e.g. ONF in state forests).

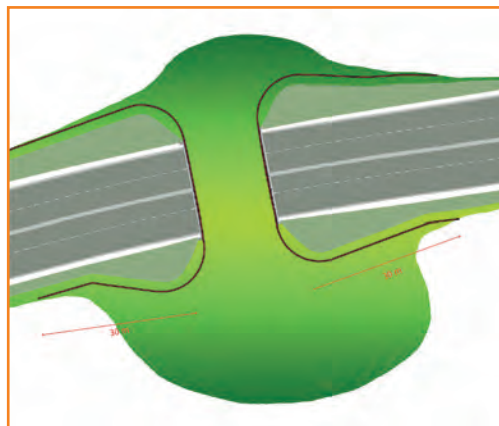

33 Schematic diagram of the installation of a screening parapet at the entrances of a fauna overpass. Source: Cerema.

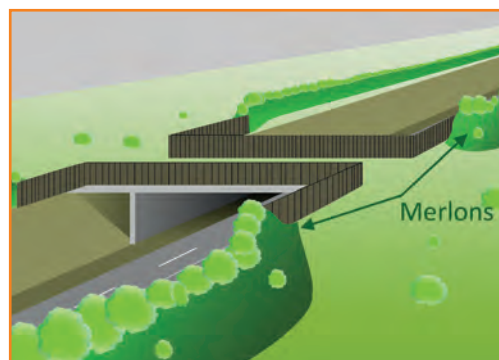

34 Schematic type of the development of an earth mound near to a fauna passage. Source: Cerema.

■ Remoteness from road rest areas (noise, lighting, movement)

Rest areas are to be avoided within 300m of the fauna passage.

■ Absence of light

The absence of artificial light in or on a structure is obviously a prerequisite, but more generally, light is to be avoided within 100m of the structure.

Limitation of obstacles at the entrance of structures

The continuity of movement must be ensured beyond the structure and must not be hindered by obstacles*, particularly connected to human activity.

■ Water ditch at the exit of the passage

If this is the case, the ditch must have ducts inserted over the entire width of the structure or at least filled with a bed of draining stones, if it has a very low flow.

■ Permanent deposit of materials

If this is the case, the materials will have to be used to improve access by shaping the entrance to the passage to ensure its accessibility and tranquillity.

■ Unnecessary services around the passage

Traffic disturbances must be kept to a minimum. Any paths that no longer have a reason to exist will be removed. In the case of a forest path or even in some agricultural cases, barriers will be installed on paths well before the structure to prevent motor vehicles from accessing the passage without justified reasons (see also fact sheet no. 6 for building the road under favourable conditions).

■ Treatment pond and its related fencing around the passage

Watercourses are used both for wildlife movement and as outlets for roadway treatment water. Treatment ponds are thus logically located as close as possible to the receiving watercourse and often at the outlet of mixed fauna and waterway structures. Treatment systems and related fencing can then disrupt wildlife access to the structure.

To limit these disturbances, it is recommended to move the low point of the profile along the road as far away from the crossing as possible, so that the treatment pond is put at a distance from the entrance to this crossing. The objective is to position the fencing (and not the pond) more than 10m from the entrance of the passage.

Fencing must also be installed in such a way as to limit the barrier effect for wildlife along the coverage. This involves:





- maintaining a 10m movement corridor between the fencing of the pond and the infrastructure (35 next page);
- preferring a treatment ditch to a pond (36 next page);
- erecting fencing with gentle angles to limit the obstacle effect* (37 next page).

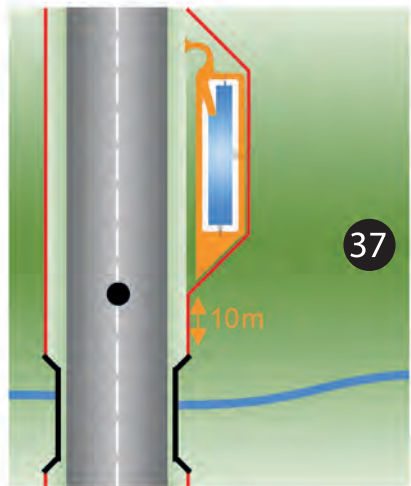
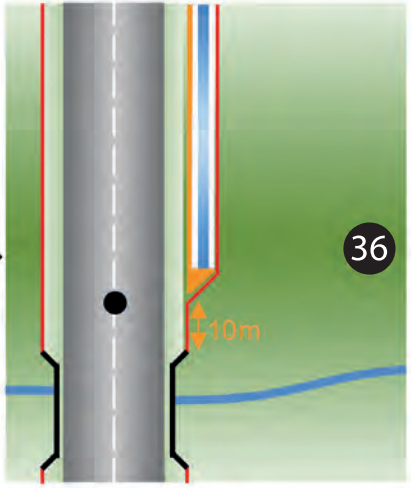
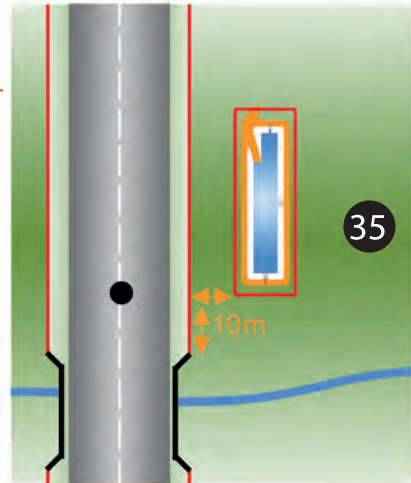
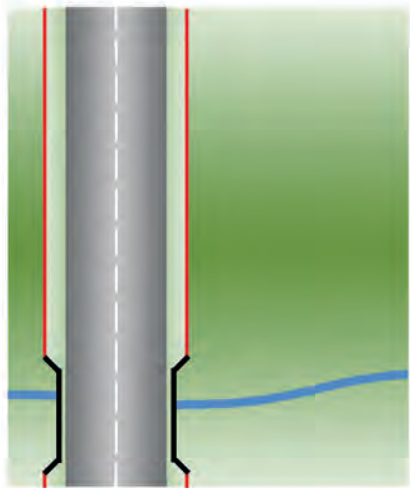

Fencing that hinders the movement of wildlife. Source: Cerema.

Schematic diagram showing the positioning of the low point of the motorway next to a treatment pond to avoid the latter from being too close to the exit of the fauna passage.
Source: Cerema.



-  Bottom of the profile along the infrastructure
-  Fencing
-  Water treatment pond
-  Water treatment ditch

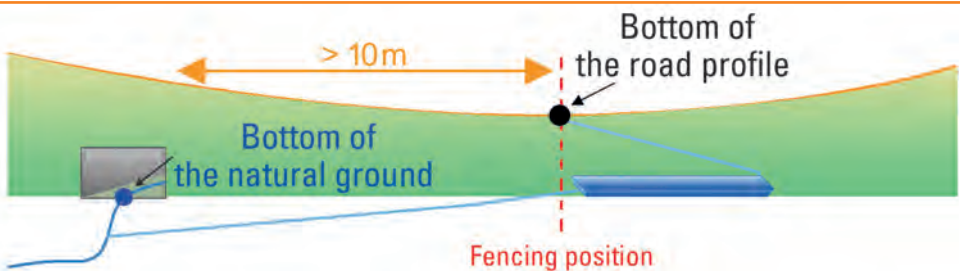

Beyond the immediate surroundings

Strengthening ecological networks

The efficacy of a passage is conditioned by the quality of its environment and more generally by the quality of the ecological network for which it is supposed to limit fragmentation. In order to improve the functionality of the ecological network, promote the use of the passage and guarantee its long-term

use, it is therefore necessary that the quality of the elements structuring the continuity be maintained or even improved. Measures must therefore be taken to ensure that the passages remain connected to the continuity and more generally to the landscape. In the context of a project, relevant compensatory and/or management measures may be taken to ensure a sustainable network of sufficient habitats within the continuity (38).



38 Schematic example of improvement of the ecological network by suitable positioning of the compensatory surfaces. Sources: Cerema, Google Earth.



How to develop all fauna passages?

Development of overpasses

- Reduce the crossing length: build abutments on front wall.
- Plant the deck by seeking to reconnect fragmented habitat structures.
- Increase favourable habitats on the deck (low walls, swaths*, etc.).
- Ensure tranquillity:
 - by masking the infrastructure from the deck on overpasses (parapet),
 - by limiting disturbances (separation of uses, anti-intrusion device, information panels, etc.).

Development of underpasses

- Reduce the crossing length:
 - provide for "wing" retaining walls (> 45°) at the exit of the structure and/or construction of a retaining vertical structure (gabion*, concrete wall, etc.) above the head of the structure to retain the embankment,
 - prefer the construction of a structure the same height as the embankment height,
 - build the structure at the highest point of the embankment.
- Planting only possible on larger structures. The main objective is to develop the surroundings to reconnect the habitats up to the entrance of the structure.
- Possible swaths in the structure.

Development of immediate surroundings

- Vegetation development is necessary to reconnect the passage to fragmented habitats.
- Ensure tranquillity ➔ by masking the infrastructure from the entrances.
- Reduce obstacles ➔ ditches, treatment ponds, rest areas, etc.

Beyond the immediate surroundings: strengthen ecological networks to entrances by additional or accompanying measures

FACT SHEET

9

What are the different types of construction? At what cost?

Type of materials⁷

Wood⁸

Wood can be used effectively as the supporting system for a structure. The structure is generally composed of solid load-bearing beams or glulam arches which act as a support for the deck. However, wood should never be in direct contact with the ground.

For the deck, it is also possible to opt for wood by building decking (a kind of floor), but it is usually preferable to work with a mixed wood-concrete framework, with a concrete slab that acts as a filler and receives the other development elements. Wooden beams are thus protected from water by the concrete slab.

It is possible to use this concept for crossings of up to 35 to 40m in length. Beyond that, the transportation of the beams becomes very complicated.

The advantages are: moderate cost, lightness, ease of transport, easy implementation, an eco-responsible approach.

Metal

Either it is used on totally prefabricated structures (metal ducts), which remain moderate in size, or on bridges whose only supporting structure is composed of metal (metal beams) (1) and concrete (slab connected to the beams). These latter structures have the advantage of a permanent weight gain and allow a crossing of

25 to 60m per span. In terms of maintenance, they do require however regular painting to avoid corrosion. Metal ducts are not recommended in a wet environment.



1 Metal structure Source: Matière TP.

Concrete

There are generally two kinds of concrete structures:

- either prefabricated structures consisting of factory-built elements that are assembled on-site. The advantages are fast construction and, usually, a low cost. The range of a prefabricated frame rarely exceeds 10 metres, but it is possible to juxtapose several frames;
- or the structures are built on-site and have a span of up to 20 or even 25 metres.





















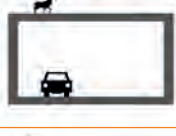

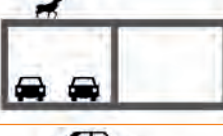

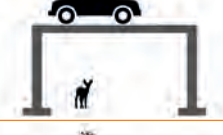
Finally, the choice of the type of structures and the type of materials depends on many parameters and varies according to the width of the structure, the size of the obstacle* to be crossed, the nature of the ground on which the structure will be based, the type of obstacle (watercourse, road, etc.), the presence of networks, the longitudinal profile of the infrastructure, the architectural choice, etc.

See Guide 7
du projecteur
Ouvrage d'art -
Ponts courants.
Cerema
(ex-Setra),
1999.





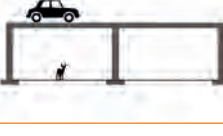







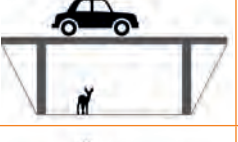

Paths 8
Cf. Ponts en bois -
Comment assurer
leur durabilité,
Cerema.
(ex-Setra),
2006.

Type de construction

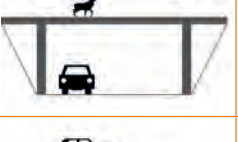
Il existe de nombreux ouvrages d'art courants qui ne seront pas détaillés, mais qui globalement peuvent être regroupés ici dans les catégories suivantes, en fonction de la taille de la brèche, c'est-à-dire de la largeur de la discontinuité à franchir (infrastructure, vallée...) :

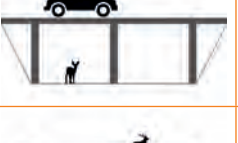
Type	Sub-type	Length of breach (B)	Type	Photograph:	Cost of construction ⁹ € excluding VAT
Metal, or concrete duct	Single	7 to 20m			€2,000 to 3,000/m ²
					
Double	2X 10 to 20m				
					
Concrete frame	Single	7 to 12m			€3,000 to 4,000/m ²
					
Double	10 to 20m				
					
Concrete gantry	Single	10 to 20m			€2,500 to 3,500/m ²
					
Double	2X 10 to 20m				
					

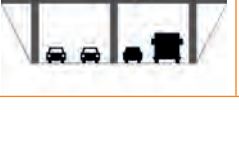
⁹ Per m² of deck area for structures with slabs or per m² of ground area for ducts and closed structures.

Type	Sub-type	Length of breach (B)	Type	Photograph:	Cost of construction ⁹ € excluding VAT
"Slab" + sheet pile		7 to 20m		 Most often linked to the passage of a watercourse	€2,500 to 3,500/m ²
				 Remains unlikely because the cost of the structure leads in this case to choosing another type of structure	
Arch		20 to 35m		 Dedicated structure for which we do not have specific references and which is to be considered on a case-by-case basis	
Mixed steel/concrete structure - "Slab" type structure (pre-stressed slab, coated beam, pre-stressed beam bridge - PRAD (regional sustainable agricultural plan), etc.)	Free-standing	10 to 20-25m			€2,000 to 3,000/m ²
	With support	> 25m			€3,000 to 3,500/m ²
					
					

1.2 Passages and developments for small fauna

What is meant by "small fauna passages" or "developments"?

While all fauna passages are also structures that are used by small fauna, "small fauna" means the construction or development of structures mainly focusing on the passage of small animals.

These may be:

- either dedicated passages less than 7m wide;
- or small spaces reserved for small fauna (< 3m wide) on other passage categories.

Small fauna passages are thus structures for exclusive use or developments associated with other structures (agricultural, forestry, pedestrian, waterway).

These are structures or developments that make it possible, overall, to ensure, without too much difficulty, minimal transparency for a large proportion of the animals, ranging from the size of a fox to the smallest species of microfauna (such as terrestrial insects). While some of these structures may exceptionally be used by larger animals (roe deer, wild boar, etc.), they can in no way be considered as transparency restoration structures for these series of animals.

Where to build small fauna passages?

A basic rule: a passage possibility every 300m

Small fauna includes both medium sized species with relatively high mobility such as foxes and badgers, but also much smaller species with sometimes much more limited movement (e.g. terrestrial insects).

Of course, economically, it is unfortunately not possible to restore all the movements of all the species whose territories are fragmented by an infrastructure and in particular those of the small common species with low movement capacity.

At the same time, an approach to conservation based solely on the restoration of permeabilities for small rare and/or protected species or related solely to habitats of biological interest is not sufficient to preserve biological diversity.

The aim is therefore to conserve a minimum transparency of infrastructure in common habitats and to increase natural environment connectivity in remarkable habitats.

Therefore, to simplify and in order to ensure the sustainability of a minimum of exchanges,

in particular for common species, **the general basic rule is a minimum restoration of movement possibilities for small fauna every 300m.**

However, the objective is not the construction of a specific small fauna passage every 300m, but a simple principle, to be respected generally at the project level, which must be applied with a minimum of flexibility. Local adjustments are thus often necessary and the development programme must take into account, in particular:

- other fauna passages already scheduled;
- technical crossing possibilities, in particular, the longitudinal profile of the infrastructure;
- the interest value of the relevant species: species, groups of species, types of movements (dispersed, seasonal, occasional, etc.), characteristics of exchanges (dispersed, wide fronts, concentrated in a corridor, etc.);
- the characteristic and structure of fragmented habitats;
- the possibility of allowing small fauna to cross structures that have other functions.

Consideration of all crossing possibilities

The implementation of the structure management plan, i.e. the number and location of passages ensuring overall transparency of an infrastructure for small fauna, must be part of a progressive approach.

The objective is to seek to respect the general 300m rule while integrating specific issues (protected species, specific groups, etc.).

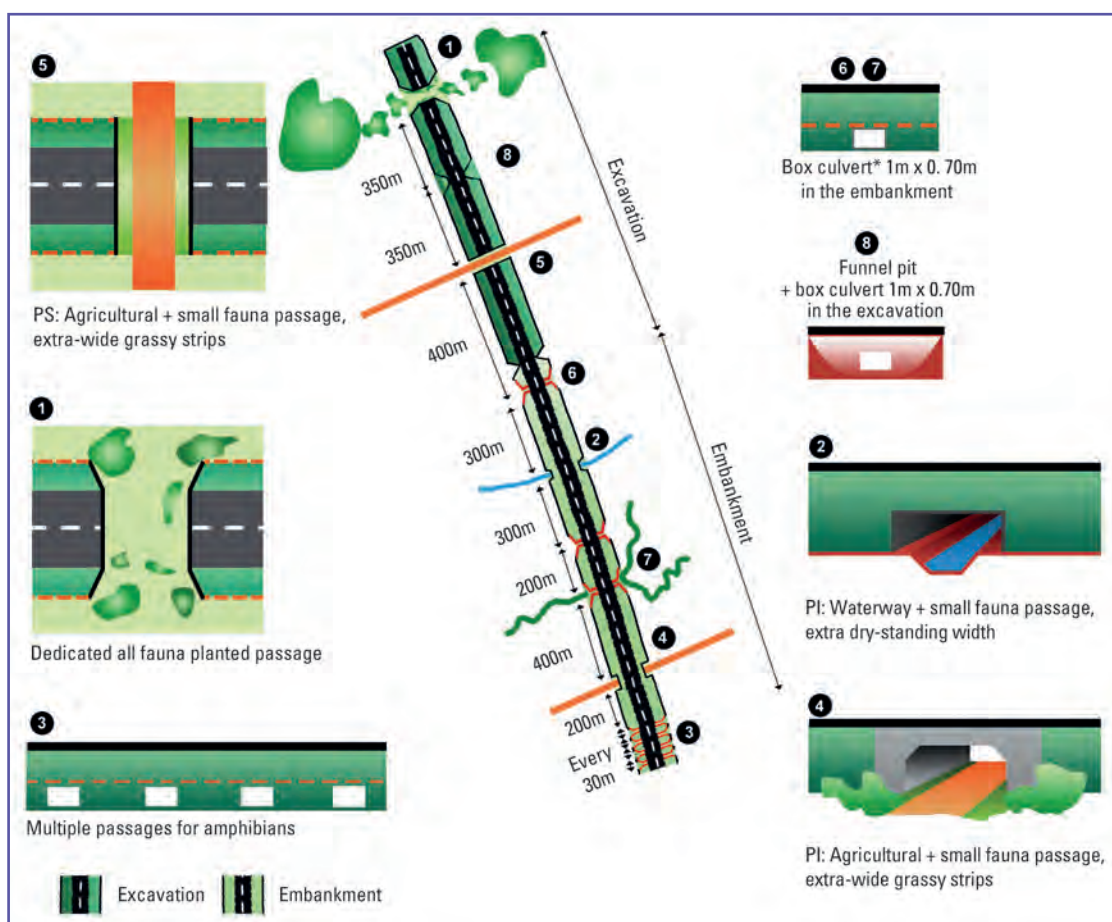

Overall layout and minimum rule requiring one passage possibility every 300m (according to J. Carsignol Cerema Est).

① This first stage of analysis must include the most favourable passage possibilities, such as tunnels, viaducts, covered trenches, hydraulic discharge structures and, more generally, all fauna passages defined in line with major ecological networks which also allow the passage of all species, including small animals (①).

② It must then integrate all waterway passages (ranging from watercourses to the smallest agricultural or forestry ditches), which, except for specific constraints, must be passable by small fauna. They must also not be movable (or hardly at all) (②).

③ Once these two categories of structure have been taken into account, the management plan must integrate data related to high issue habitats and species (heritage and/or protected species, groups of specific species). Each situation is then specific. It is here, depending on the level of the species' issues, the spatial analysis of habitats, the characteristics of populations and their home ranges, that small fauna passages can prove indispensable on well-defined sections.

This is the case, for example, when the infrastructure sections a migration route* for amphibians. An additional density of restoration structures is then required and their locations are difficult to modify (③).

④ Finally, once all the previous structures are positioned, the management plan must be completed by the definition of additional small fauna passages so that wildlife has at least one passage every 300m. In this case, either there is an agricultural or forestry restoration structure near the interval and the choice depends on the basis of the development of this structure (④ and ⑤), or in the absence of any other passage possibility, an additional structure must be provided (⑥, ⑦ and ⑧). If the 300m rule is an average to be respected, this distance is not fixed and the installation of the structure must also take into account local issues, such as landscape structures potentially favourable to movement (hedges, wooded areas, etc.) or the most interesting environments from a biological point of view (e.g. prefer a lawn to a crop, even if the environment can potentially be modified in the more or less long term, a hedge, a forest edge, etc.) (⑦).

If this approach does not pose major difficulties in principle, when the project is in a major embankment, difficulties can arise when the longitudinal profile is in the cutting or the infrastructure is at the natural ground level or on a slight embankment.



Badger tracks, among others, in a structure of the A35 motorway (Grand Est region). Source: Cerema.

The development is then dependent on the possibility or not of the construction of passages under the roadway (access to the structures from the funnel pits or sloping structure heads⑧). The main difficulty lies in the risk of flooding of these structures. The possibilities thus depend on the characteristics of the ground, the presence of shallow aquifers, the possibility of developing drainage systems, etc. The objective is that these structures remain dry for most of the year.

While the planning of specific overpasses for small fauna is not inconceivable, it remains rare and linked to the presence of specific small fauna issues. However, on excavated sections, when the issues are very high, the impossibility of multiplying the number of small fauna structures generally leads to the creation of larger structures (all fauna passage).

How to develop small waterway structures for small fauna?

All waterway structures associated with a major infrastructure project should be developed for the passage of small fauna, unless particular constraints are put forward and justified.

The primary function of these structures is to transit surface flows (temporary or permanent) or watercourses intercepted by the infrastructure. It is through their ancillary facilities that they can also ensure the passage of small terrestrial fauna. These ancillary facilities must be scheduled from the early stages of sizing of waterway structures, so that they can meet the identified objectives of restoring the passage of small fauna and free movement of fish, and so that their cost may be properly assessed.

Unlike dedicated fauna passages, these structures have the particularity of having a well-defined location that is hardly or not at all modifiable. With some exceptions, they are located at the natural ground level and generally at the bottom of the talweg or at the level of topographic low points. For small flows, they can transfer water from a temporary ditch or dry talweg to one side of the infrastructure.

Depending on the type of flow (temporary or permanent watercourse, ditch) and the possibilities of fitting a bench*, several categories of structures are distinguished.

Mixed small fauna structures/restoration of a watercourse or ditch

These are the waterway structures necessary for crossing watercourses and ditches and equipped with benches* whose width remains less than 3m (when there is more than 3m on each side of the structure, the passage tends to be considered as an all fauna passage, see fact sheet no. 6).

Large watercourses generally constitute important movement corridors and therefore most often require structures with sizing of the spaces

reserved for an all fauna passage. Only very particular situations (e.g. very specific context linked to the total absence of issues) can lead to the absence of crossing possibilities for wildlife. However, this situation remains exceptional and will need to be justified.

Small rivers and ditches also constitute ecological networks, often supporting large biological flows that must be maintained or restored.

Choice of type of waterway structure (open or closed structure)

Two categories of structures are mainly used to restore these continuities:

- "open structures on supports without a foundation raft" (1 1) (gantry, masonry arch without foundation raft*, slab bridge) ;
- "closed structures" (frame, duct, masonry arch with foundation raft*) (1 2).

For the restoration of a watercourse, even if they can be used, ducts are not necessarily recommended, because compliance with the recommendations (height above the bench*) often leads to the implementation of larger structures, which makes them economically less advantageous compared to another passage types (see diagram on the following page).



Definition of a watercourse

Article L.215-7-1 of the French Environmental Code* resulting from the Act of 8 August 2016 for the recovery of biodiversity*, nature and landscapes defines the concept of watercourses as:

"A flow of running water in an originally natural bed, supplied by a spring and having sufficient flow for most of the year. The flow may not be permanent given the local hydrological and geological conditions".

Water police services are responsible for mapping these watercourses, even if this map remains indicative and has no legal scope as such.

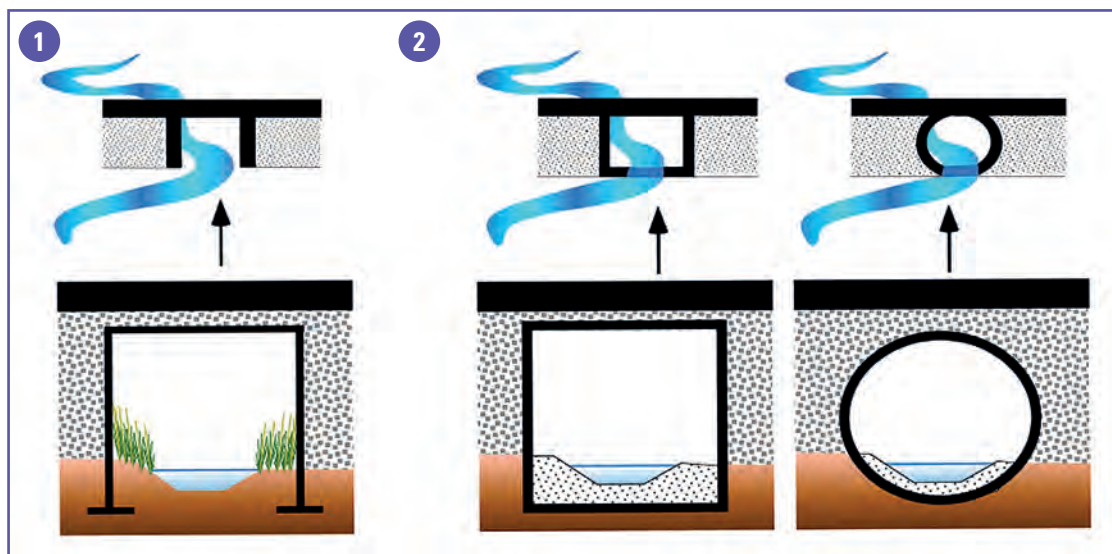

1 Principle of implementation of open and closed structures:

- 1 open structure (or gantry): no modification of the low-water bed, bottom and "natural" banks, most often without temporary diversion during the works phase;
- 2 closed structures (or frames): modification of the low-water bed, reconstitution of the bottom and banks, temporary diversion during the works phase.

Source: Cerema.



The use of a duct or arched structure often leads to creating larger structures to respect both the minimal height of the foundation raft* and the headroom* between the dry-standing area and the top of the structure.

Diagram comparing a duct and a frame to comply with the minimal recommended headroom above the dry-standing area to guarantee the fauna passage.*
Source: Cerema.

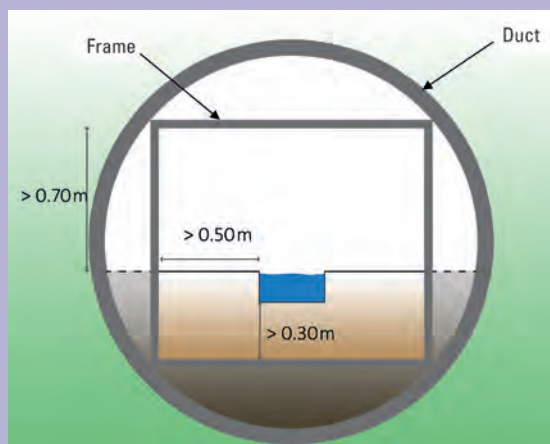

■ Open structures

Open structures are preferable on watercourses, because they help preserve the dimensional characteristics of the low-water bed and the banks (widths, slope, particle size) before development. This structure category, however, requires the size of the structure to handle the flow of floods without overloading the structure and without increasing velocity too sharply, otherwise the banks and dry-standing area, even natural, would rapidly erode.

In the case of morphologically degraded or altered watercourses (enlarged or incised bed), open structures also offer the possibility of recreating a bed that allows flows compatible with crossing fish (in terms of water heights and flow velocity).

This type of structure should also be preferred when the ecological issues for small fauna are high (maintenance of a favourable natural soil), but also according to the issues of the aquatic environment:

- when there are significant aquatic continuity issues (heritage species, watercourses classified under L.214-17 of the French Environment Code* - lists 1 and 2);
- when the watercourse is home to fish with a low swimming and jumping capacity (Planer's lamprey, bullhead, etc.);
- when the watercourse gradient is above 3%. Beyond this, with a closed structure, the reconstruction

of a 30cm foundation raft* in the downstream part of the structure requires burying the upstream part of the structure in depth (e.g. for a 25m long structure to maintain a 30cm foundation raft* downstream, the structure must be buried more than 1m upstream) (next 2 page).

These structures are also selected according to the geotechnical quality of the land (sufficient bearing capacity), otherwise it would be necessary to add special devices (adapted foundations, large purges) which are potentially more expensive.

■ Closed structures (frame, duct, masonry arch with foundation raft*)

These are structures with a foundation (foundation raft*). Although they have the advantage of providing the structure with good bearing capacity, even when the ground is of poor quality, the presence of the foundation raft (bottom) leads to work being carried out in the low-water bed.

Beyond taking into account the terrestrial fauna, the development of a new low-water bed within the structure then requires taking into account certain recommendations:

- for ditches, the aim is to ensure hydraulic continuity and, in this way, should not act as an obstacle* to flows;
- for watercourses, hydraulic continuity is added to the fish continuity as maintaining fish circulation is mandatory¹⁰.

¹⁰ See Order of 28 November 2007 fixing general provisions applicable to installations, structures, works or activities subject to declaration pursuant to articles L. 214-1 to L. 214-6 of the French Environment Code* and falling under section 3.1.2.0 - 2*.

In this case, it is necessary that:

- the bed of the restored watercourse respects the initial dimensions of the low-water bed (if the bed of the watercourse is natural), or even improves its dimensions when the watercourse is morphologically degraded, so as to restore water heights and flow velocities compatible with the fish crossing. An excessively small width in fact leads to an increase in flow velocity, running the risk of preventing fish from moving up the current. Excessive width leads to a reduction in the water depth in the structure, at the risk of being no longer sufficient for fish to pass through;
- the water height in the structure is sufficient, especially during periods of low water;

- the structure is positioned following the slope of the watercourse (to avoid erosion at the structure's entrance or exit);
- the upper level* of the foundation raft* is located between 30 and 50cm under the natural bed of the watercourse (2);
- the natural bed in the structure consists of an identical substrate or similar to the natural substrate of the watercourse;
- that any increase in velocity in the structure (especially during flood episodes) does not tear off materials from the bottom, in which case specific measures must be implemented (energy dissipator, increased granulometry, gabion mattress*, stabilisation bars, etc.).

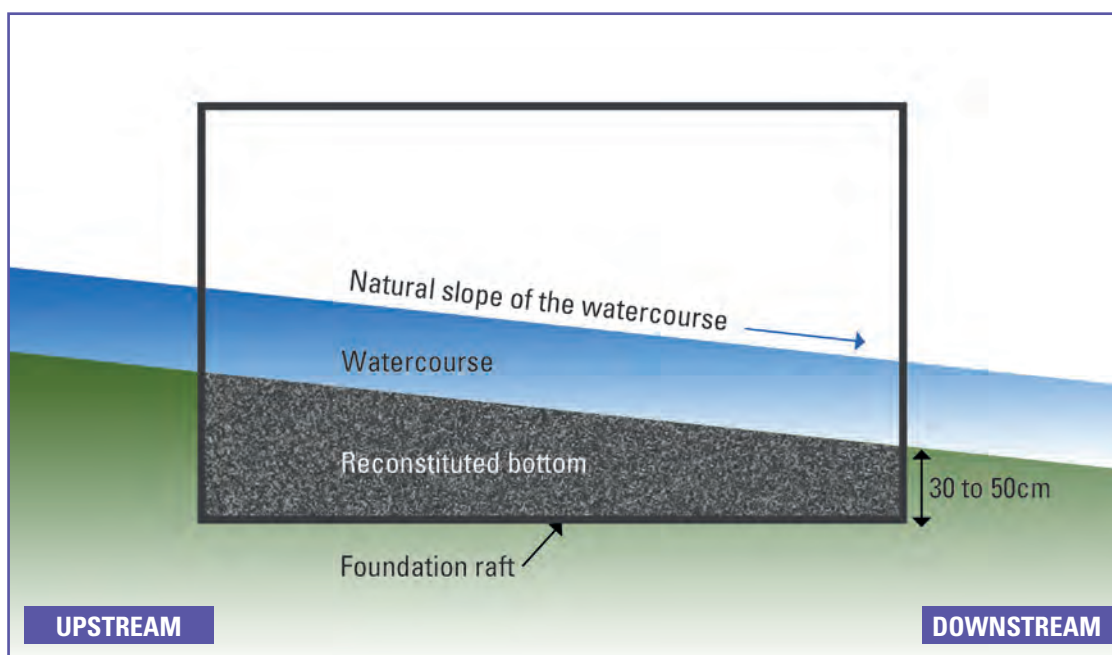

2 Schematic diagram of the layout of a waterway structure with a foundation raft. Source: Cerema.



Fish continuity

For structures to ensure fish continuity, they need to comply with other recommendations, especially on small structures (see *Note d'information : petits ouvrages hydrauliques (section 4 m²) et continuité écologique*, SETRA, 2013):

- flow velocity for flows between the QMNA* and 2.5 x the interannual module lower than the "cruising" swimming speed of the species present (possibility otherwise of setting up energy dissipation devices, rest areas);
- enough headroom during the low water period, depending on species.

Dimensions of the small fauna bench*

Specific requirements for the small terrestrial wildlife area apply to both closed and open structures.

Beyond the need to maintain hydraulic transparency and to integrate the mobility of the watercourse, if it exists, the structures must also be sized and adapted to meet the requirements of small terrestrial fauna. These requirements (③) correspond to:

- the presence of a bench* at least **0.5m** wide **each side** of the watercourse. This reference width must exclude the slope of the bank up to its top, as it forms an integral part of the low-water bed (see diagram on the next page);
- the free height under the structure above the entire length of the bench* must be at least **0.7m**. However, when technical constraints (to be justified) demand it, it is possible to reduce this headroom* to 0.5m and the width of the passageway to 0.3m (except in the presence of beavers).

- the slope of the banks, when reconstituted, must correspond to the slope of the banks on either side of the structure. In all cases, it must be at least 1: 1 or even 2: 1, when they are made of natural materials.

When the bed is reconstructed (closed structures), the height of the bench* must be adjusted to the bankfull flow (i.e. on the top of the banks) corresponding to **the return flood flow of approximately two years (1 to 3 years)**. This is an important consideration, as undersizing means that the structure will frequently be unusable.

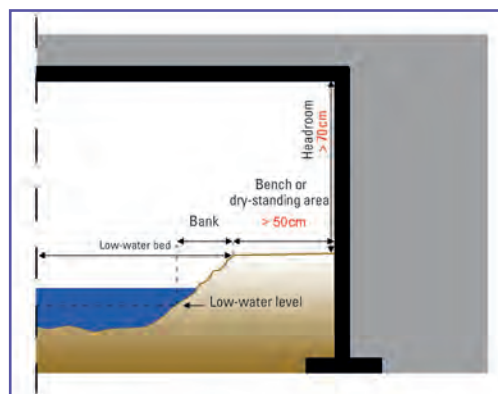

③ Schematic diagram of a small fauna bench in a waterway structure. Source: Cerema.



Restoration of a passage for anglers

When the structure must also allow the passage of anglers, the height available above the bench* must be greater than 2m (2.5m is recommended) and the width greater than 1.5m.

It is also possible, or even necessary in some cases (see insert below on the European mink and otter), to design stepped benches* to allow the crossing of fauna during major hydraulic events. The duration of these hydraulic events is a major decisional factor for positioning the other benches*. Indeed, while the passageways are drained in a few hours, the partitioning induced does not appear to be significant. For immersion times exceeding 24 hours, upper benches* may then be required. In general, it is then recommended to position

one of the benches* on the return flood flow for 5 years (sometimes 10 years) because, beyond that, it is generally the entire bottom of the valley that is flooded. For heritage species such as the European otter, beaver and mink, the bench* should be adjusted to the 10-year return flow. If the bottom of the valley is flooded with these flows, an additional dry-standing passage is to be considered higher in the embankment (see fact sheet no. 11 "Waterway structures associated with a dry conduit").



Case of the European otter, beaver and mink

Stepped systems are particularly recommended when the watercourse supports a movement corridor for small aquatic or semi-aquatic heritage mammals. Although some of these species can swim, they prefer to cross the structure on the bank (Bouchardy et al., 2001). Thus, when these structures are completely flooded, animals tend to climb up the embankment and pass over the road, at the risk of being hit, rather than swimming in the structure.

To limit the risks for these species during the year, artificial banks, guaranteeing a dry passage, must be calibrated on the highest flow values (at least 10-year flood frequency).

This calibration may then require an increase in the size of the structure. In this case, it is possible, if the width of the structure allows it, to provide more benches* whose heights will be based on several intermediate flows.



Stepped bench (concrete).
 Source: P. Fournier GREGE.

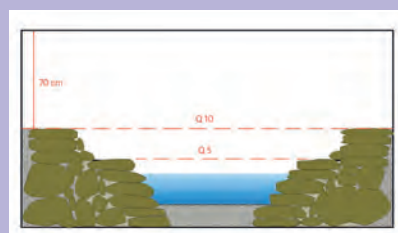

Schematic diagram of a stepped bench
 Source: Cerema.

For stepped benches*, care must also be taken to connect them both to the lowermost banks and to the road embankment for the highest levels. Indeed, animals must be able to continue to circulate through to the bench* when the

rest of the structure and the valley is flooded (④). If this option is chosen, each bench* must have a **minimum width of 40cm** and the **maximum space between two levels must be 50cm**.

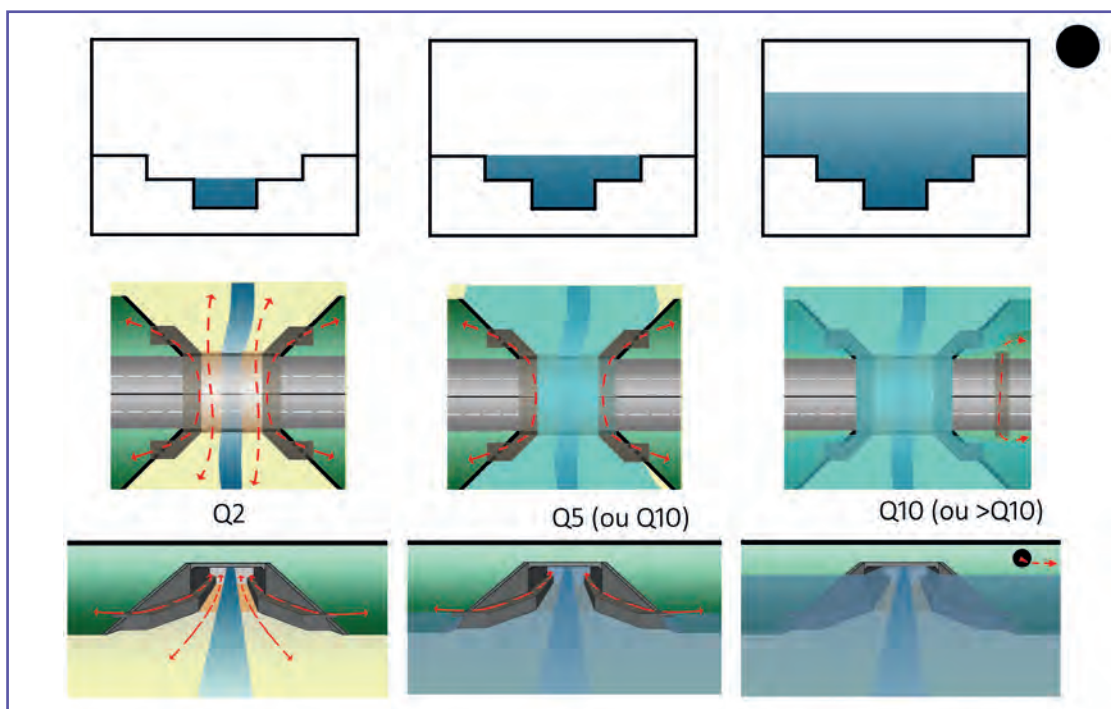

④ Representative diagram of the possibilities of crossing a structure equipped with a small fauna stepped bench at different flow levels. Source: Cerema.

The dimensions of a waterway structure must also be adjusted according to the length of the crossing. To ensure effective crossing, the opening¹¹/length ratio must meet the following requirements:

- where the watercourse does not host any fish:
 - the opening/length ratio must in all cases be ≥ 0.25 ,

– where the watercourse hosts fish fauna:

Cover length	Opening/length ratio
$L < 30\text{m}$	≥ 0.25
$30 < L < 60$	≥ 0.5
$L > 60$	≥ 0.75 or search for another type of structure



Even on small waterway/fauna restoration structures, the length of the crossing can be shortened by the implementation of a retaining wall above the structure head, to hold back the embankment.

*Retaining wall built above a waterway structure to limit the length of crossing.
Source: Cerema.*



Constructional provisions of a small fauna bench*

For enclosed structures, the reconstitution of a low-water bed is also accompanied by the reconstruction of new banks and the construction of benches*. While the restoration of these natural material spaces seems attractive, it is not always possible. Indeed, the increase in velocity in certain structures is not always compatible with the retention of materials, in particular the finest ones.

Depending on the situation, some recommendations can be followed:

- when in periods of high water, the velocity in the structure is less than 1m/s and the width of the flood channel is less than or equal to the width of the structure (i.e. the bench* is not totally submersible):

the banks and the dry-standing area are built in materials identical to the natural banks of the watercourse or ditch (5). However, the reconstitution of these banks requires the protection of these new banks with a biodegradable geotextile to ensure good resistance in the first years, while they stabilise, especially when it comes to fine materials.

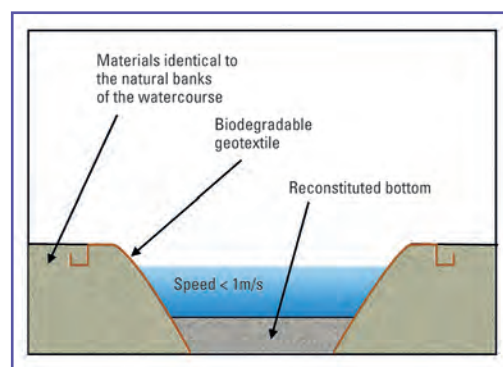

5 Schematic diagram of bank reconstruction (and dry-standing area) in materials identical to the natural banks of the watercourse. Source: Cerema.

¹¹ For example, for a rectangular structure, it involves the section = (width X height) and for a duct of (IIr²).



Example of a bench made in natural materials.
 Source: Cerema.



Example of a work in which some bends have been made in the low-water bed. Source: Cerema.

On watercourses, when the size of the structure allows it (compliance with the width of the bench* of at least 50cm throughout the crossing), the creation of bends could be considered to diversify the low-water bed in the structure. These bends can be achieved by using blocks (20-50cm). They create these bends and the necessary roughness (limiting current speeds) to protect the banks from erosion (in concave bends of the bed) (6 and 7).

- when the flood channel of the watercourse is greater than the size of the structure: the reconstituted banks must be sufficiently stable to prevent the materials from being torn off during strong hydraulic events. Also, if, after verification, it is found that natural materials present a risk of being torn off during floods, several types of development can be envisaged:

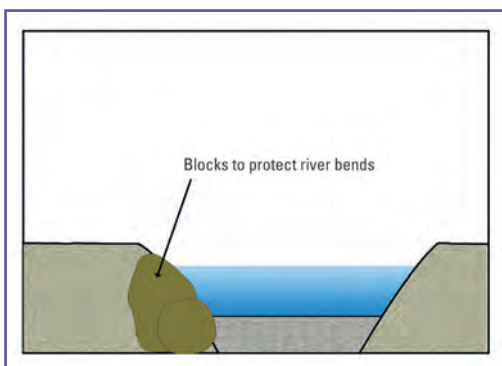

6 Cross-section of a structure using blocks to form bends within a structure. Source: Cerema.

- 1 Creation of banks with masonry blocks (8): the bench* is predominantly made up of large block rockfill accompanied by smaller sized materials (e.g. category 0 to 31.5mm) to fill in the empty spaces. The banks themselves consist of a concrete laying bed (made with a 1 to 1 slope), into which blocks of 20-30cm (up to about half their thickness) are inserted. These protruding blocks make it possible to maintain roughness in the low-water bed of the watercourse and thus to limit flow velocity.

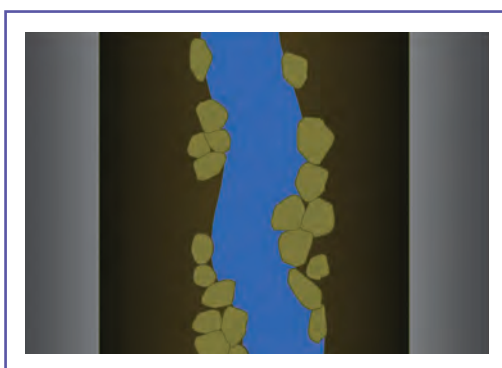

7 Schematic plan view of a structure using blocks to form bends within a structure. Source: Cerema.

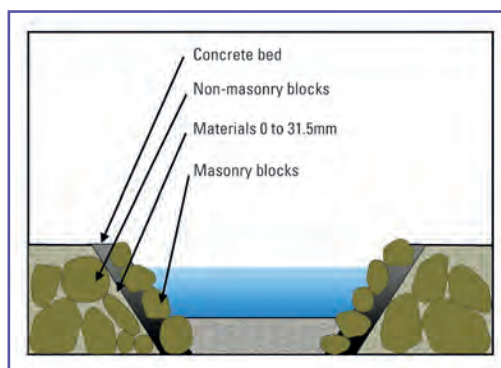

8 Schematic diagram of reconstruction of banks with masonry blocks. Source: Cerema.



Restoration of a watercourse under the structure with masonry banks. Source: Cerema.

② The rockfill of all the banks using natural blocks or slabs (⑨):

these elements must be large enough (> 30cm) and arranged one on top of the other in a staggered formation to keep them in place. Thinner elements (0-31.5mm) fill in the gaps.

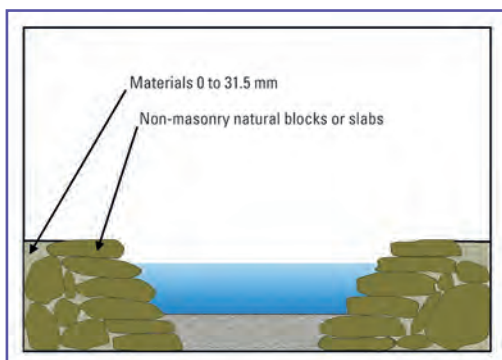

⑨ Schematic diagram of reconstruction of banks with masonry blocks or natural slabs. Source: Cerema.

③ Laying of gabion* rolls and beds (⑩ and ⑪):
the advantage of this technique is to stabilise the banks while offering many hiding places between the stones and trapping fines.

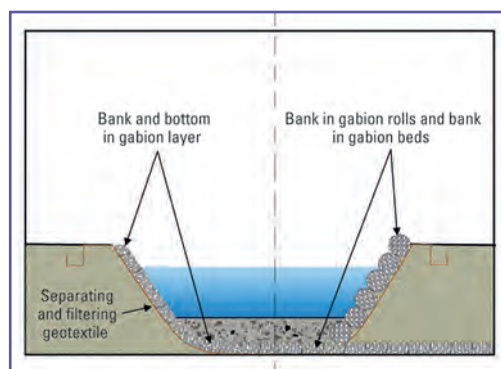

⑩ Schematic diagram of the reconstruction of banks with gabion rolls*. Source: Cerema.



⑪ Reconstruction of banks in gabion mattresses*. Source: AquaTerra Solutions.

In all three cases, a sinuous low-water bed may also be considered.



The construction of concrete vertical edges or concrete benches is not recommended for two reasons:

- they do not allow an animal to climb out if it falls into the water;
- the lack of roughness on the banks increases the velocity of the watercourse in the structure.

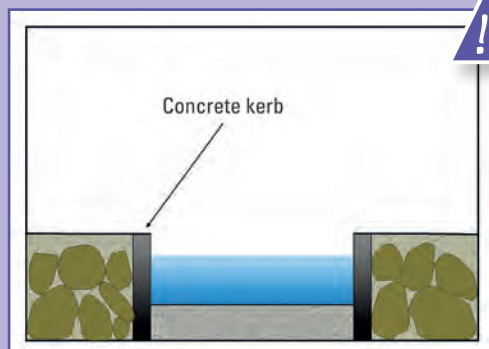

Concrete vertical walls Source: Cerema.

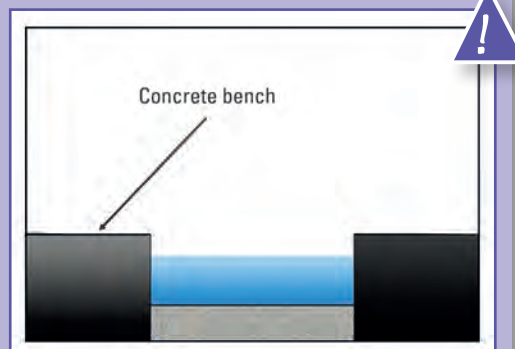



The presence of a fauna bench within a waterway structure is not decisive in the cost of the structure. It is the oversizing of the structure to create benches, as well as the implementation and site management (temporary bypass, excavation, purge, substitution of materials, sealing, etc.) which impact the final cost.

For example: constructing a simple small fauna frame of 2X1m on the Port-sur-Saône diversion (Grand Est region) cost around €800 /lm, while the construction of a waterway structure of similar dimensions (2x1.5m) on the VR 52 (Grand Est region) cost more than €4,000/lm.



There are also prefabricated bench systems that are integrated directly into the structure. These can be solid concrete benches or corbelled benches*. If possible, these systems must be reserved for the development of existing structures with similar equipment (e.g. extension of an existing structure, for example in the context of a dual carriageway connection), in particular for the reasons mentioned above (see "Point of vigilance" insert).



Frame element equipped with a prefabricated concrete bench. Source: Cerema.



Frame element equipped with prefabricated concrete corbelling. Source: Cerema.

Additional recommendations and adjustments to the small fauna benches*

■ Connection and protection of banks at the entrances to the structures

At the exit of the structure, the banks must in all cases be connected to the natural ground so that the terrestrial continuity is maintained, otherwise the passage will not be functional (13 next page).

Moreover, upstream of the structures, the points of contact between the bench* and the natural bank of the watercourse very often constitute erosion points. The difference in resistance of materials to the action of the current is in fact accompanied by accelerated degradation phenomena between the bench* and the natural banks and leads to the formation of steps at

the entrance of the passage (14 next page). To prevent these localised phenomena, it is recommended to:

- extend the benches* beyond the structure;
- stabilise the banks at the exit of the structure (12);
- limit the catching of the current on the potential erosion point, for example by creating a bench* with an angle formed with the bank of around 45° (15 next page).



12 Structure exit developed to maintain the banks. Source: P. Fournier GREGE.



13 Bench in natural materials not connected to the bank. Verdenal structure (54). RN4 Strasbourg-Nancy. Source: DIR Est.



14 Presence of a step at the entrance of the passage limiting access to the smallest species. A34 Reims, Charleville-Mézières. Source: Cerema.

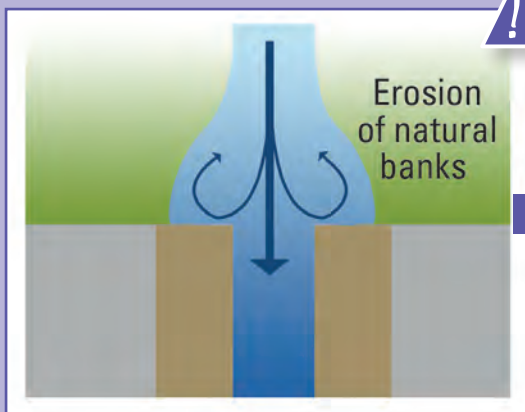

15 Schematic diagram of a small fauna bench likely to cause the erosion of the banks at the entrance of the structure. Source: Cerema.

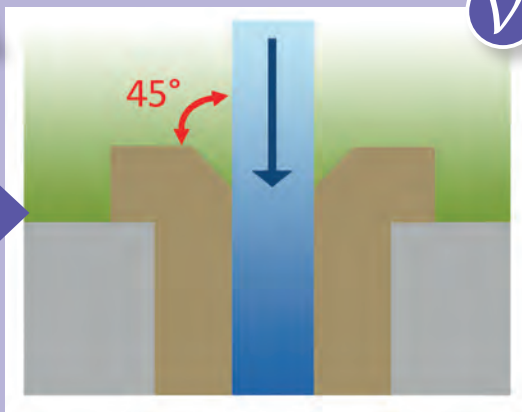

16 Schematic diagram of the layout of the small fauna bench at the entrance of a structure to avoid erosion of the banks. Source: Cerema.

■ Development of ancillary habitats

Like passages for large fauna, when the flow rates in the structure remain moderate or when the benches* are unsinkable, it is possible to improve the attractiveness of the structure by providing shelters for the smallest animals through the implementation of swaths* which, in waterway structures, are simple strips of pebbles and blocks (no wood). These can be installed against the walls of the structure. If the system is liable to be subjected to the current, the size of the materials

must be defined according to flow velocity to prevent them from being torn off. With blocks larger than 20cm and possibly sealed in part (taking care to maintain a maximum number of shelters), the risks of tearing remain moderate on the majority of small watercourses.

Specific developments creating either shelters or a covered pathway (16, 17 and 18 next page) are very useful for micro-mammals*, in particular for water shrews (*Neomys fodiens* or *Neomys anomalus*) or for water voles, both protected species.

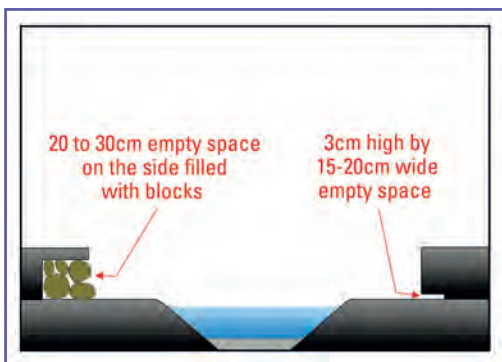

16 Schematic diagram of the construction of shelters within fauna benches. Source: Cerema.



17 Example of shelters created in the fauna bench of a structure. Source: Michel Bramard OFB.



A "micromammalian notch" * device designed by GREGE on a structure redeveloped by ASF/ Vinci Autoroutes on the A89 (also installed on the LGV SEA) showed during the course of the first efficacy monitoring that this covered route was particularly frequented by micromammals*, with more than 400 passages recorded, including 273 water shrews coming to hunt in the shelter.



18 Development within the fauna bench of a passageway for micromammals*. Source: P. Fournier GREGE.

Waterway structures associated with a dry conduit

When the characteristics of the project do not allow the inclusion of a bench*, the solution consists in fitting a dry conduit (see sheet no. 14: dedicated common structures) near the waterway structure. The structure must at least be located above the side of the bankfull discharge bed (estimated return flow rate of 1 to 3 years), i.e. above the side of the banks of the low-water bed.

Whenever possible, however, it is recommended to install the structure at the highest level in the

slope to avoid any risk of flooding, even during significant events.

For semi-aquatic heritage species, the structure must be set above the 10-year flow rate (see sheet no. 11 "Development of waterway structures"). A device, such as fencing, can also prevent species from accessing the road.

The positioning of the duct at a level higher than the hundred-year flow rate means it would not need a water police file.

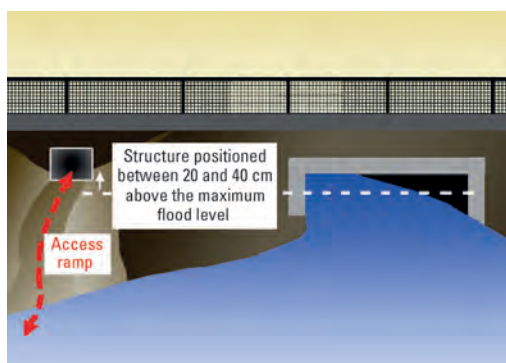

Schematic diagram of the installation of a dry conduit next to a waterway structure. Source: Cerema.



Example of a dry conduit development. Source: Vinci Autoroutes/ASF network.

Temporary flow restoration waterway structures for dry talwegs

These are usually small structures such as ducts, ovoid conduits, box culverts*, generally less than 1m high. These structures are used to restore small temporary natural flows or flows linked to water treatment, without, however, this being run-off water from roadways (polluted).

In these structures, it is not necessary to guard against the risks of immersion. For these structures to be considered as small fauna passages, they only need to remain passable for a large part of the year, that is to say outside periods of heavy rainy events and for a fairly short period because of their drainage. Apart from these major events, these structures must remain partly or totally dry.

Recurrent problems encountered on this category of structures are generally observed during intermediate periods, that is to say during slightly to moderately rainy periods during which small fauna must be able to cross the structures. During these periods, these structures, although under little hydraulic stress, are generally flooded in part or over the entire length and crossing by small fauna is disturbed or even impossible (22 and 23 next page).

For this reason, it is recommended to create systems for concentrating small flows in order to restore passability as rapidly as possible. This involves:

- either creating a notch or small concrete bench* 2 to 4cm high, depending on the flows. These devices can be factory-made on request when the elements are manufactured or produced on-site (18 and 20 next page);
- or setting up a drain system within the structure or a conduit if the flows are permanent, topped by a bed of draining pebbles (21 next page) leading to a diffusion pit at the structure's exit.

These devices need to be implemented as and when the elements are laid, since once all the elements have been laid, it is difficult to intervene in the structure.



19 Schematic diagram of systems for concentrating low flows in a structure. Source: Cerema.



20 Culvert frame with prefabricated funnel.
Source: Bonna sabla.

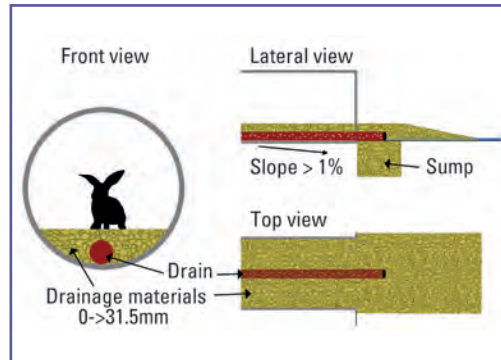

21 Schematic diagram of drainage of a structure to keep the fauna passage as dry as possible. Source: Cerema.



22 Build-up of materials at the outlet of the structure preventing drainage of the structure. Source: Cerema.



23 Flooded structure limiting the crossing of certain animals at least part of the year. Source: Cerema.

FACT SHEET

12

How to develop agricultural/forest/pedestrian structures for small fauna?

All agricultural and forestry or even pedestrian restoration structures, whether underpasses or overpasses, do not necessarily need to be built under the conditions of an "all fauna" passage, if their location does not strongly contribute to restoring the ecological network.

Even if they do not have an ecological vocation of primary importance, their characteristics may, however, after some adjustments, offer favourable crossing possibilities for a whole series of small terrestrial animals. On the other hand, they play a very minor role in maintaining biological exchanges of large fauna, even if there may be occasional passages.

It would therefore be regrettable not to take these opportunities into account in order to ensure the maximum overall transparency of the infrastructure.

Overpasses are of particular interest because they are generally located on excavated sections where it is difficult to install dedicated small fauna passages such as ducts or box culverts*.

The development of these passages consists, as with all fauna passages, in creating a space conducive to the passage of animals on either side of the path. However, the reserved space here is limited to **vegetated strips of land 1 to 2m long** on each side of the path (①, ② and ③ next page).

On overpasses, a thin layer of soil about twenty centimetres thick is then sufficient to install simple herbaceous plants, or even some shrubs. The installation of a small swath* or a few piles of stones can also be envisaged on these structures (overpass or underpass).

As the space is quite often reduced, it is possible to separate uses by using small concrete curbs along the path (they allow motorised users to

be guided without it constituting a real overlap constraint for these vehicles).

To avoid wildlife vehicle collisions, however, it will be necessary, on a regular basis, to install inclined curbs so that smaller animals who access the structure by road can always access the grass verge from the roadway.



Use of grass verges by sand lizards

Source: Daunicht, 2011.

In Germany, the monitoring of sand lizards on and next to a passage fitted with a grassy bench demonstrated the use of a strip of vegetation by individuals.

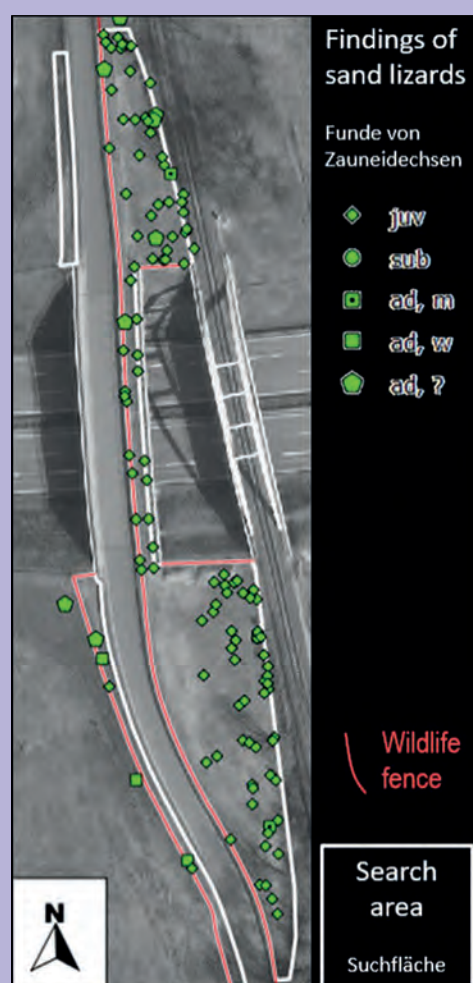



1 Agricultural and small fauna underpass.
 Source: Cerema.



2 Mixed overpass equipped with grass verges.
 Source: Cerema.

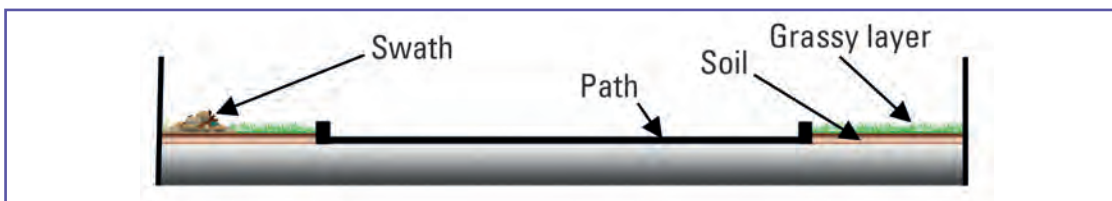

3 Schematic diagram of the development of grass verges on an overpass. Source: Cerema.

€ The cost of a grassy bench is essentially linked to the increase in the total width of the structure. See fact sheet no. 9.

There are also other more specific devices relating to the construction of structures that restore surfaced paths or roads.

The objective is then to offer a possibility of safe passage for small animals by completely separating the roadway from the small fauna passage.

However, this solution requires a few precautions to ensure minimum protection of individuals on leaving the structure (4).

While these solutions are conceivable, they remain relatively expensive. They are to be reserved for very specific issues or for long sections on which there are very few opportunities for restoration.

To limit the width of the structure and the costs, it is also possible to envisage lighter metal structures to back the structure which do not require the widening of the slab of the structure (5).

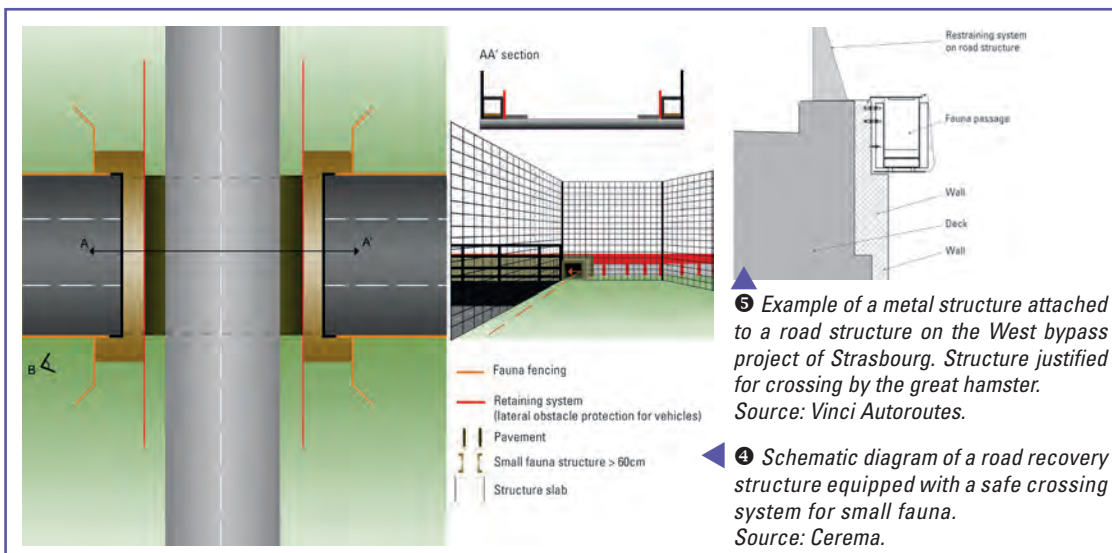

5 Example of a metal structure attached to a road structure on the West bypass project of Strasbourg. Structure justified for crossing by the great hamster. Source: Vinci Autoroutes.

4 Schematic diagram of a road recovery structure equipped with a safe crossing system for small fauna. Source: Cerema.

FACT SHEET

13

How to develop specialised structures (amphibian passages–tree canopy passages)?

These are structures carried out for a species or group of species whose biological value or ecological specificity makes it necessary to develop particular structures¹².

The decision to create a specialised small fauna structure is based on several criteria:

- biological: level of issues of the species or group of species, type of movements (occasional,

daily, seasonal, etc.), characteristics of exchanges (dispersed over a wide front, concentrated in a corridor, etc.);

- technical: possibility of crossing (overpass, underpass), complementarity with common structures.

Amphibian passages or “batrachian tunnels”

Typical road crossing structures for amphibians (still also called “batrachian tunnels” or “toad tunnels” or “small fauna crossing”) correspond to a combination of two devices:

- a crossing system comprising a series of tunnels under the roadway, spaced apart at various lengths;
- and a barrier and collection system designed to prevent amphibians from accessing the roadway and guiding them to their underpass tunnels (or crossings).

These systems are to be installed on the entire migration corridor* taking into account the movement route of individuals between living and reproductive environments (1 opposite).

¹² Supplements are available in the following report: *Amphibiens et dispositifs de franchissement des infrastructures de transport terrestre*, Cerema, 2019.

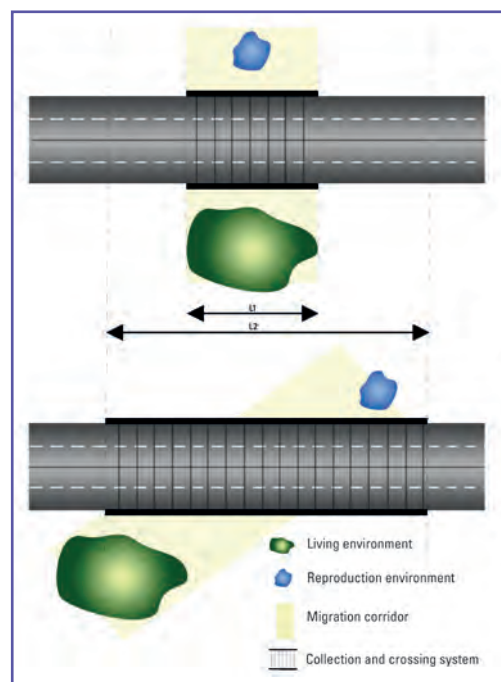

1 Schematic diagram of an amphibian collection system according to the species migration corridor.

Source: Cerema.

There are two main installation categories:

- two-way crossing systems;
- one-way crossing systems.

Two-way crossing system

For the past decade, this system has been the most widely used, in particular because it is the simplest to install and is considered to have the best cost-benefit ratio. Unless there is a particular topographic configuration, **this is the preferred system**.

■ Description

This system combines a device for collecting amphibians such as a low wall or angle-based system (or even fences) installed on each side of the infrastructure with a series of simple conduits under the roadway, spaced regularly along the system. The main feature of the structures of this device is that they can be used in both crossing directions (outward and return migration).

■ How it works

Migrating amphibians (post- or pre-nuptial) are stopped by collection barriers, high enough to be impassable by the vast majority of species. Individuals will then follow them along the verges until they reach the underpasses.

■ Constructional specifications

L-shaped collection barriers

There are different shapes (②) and different types of L-shaped collectors: concrete (④), metal, plastic.

The above-ground height of the collectors must be greater than 40cm (or even 60cm if the agile frog is present) so that they can really guide movement. For better efficacy, a return ledge (flap) is also recommended (> 10cm) at the top to avoid any attempt at climbing (e.g. urodela*, tree frogs).

Collection barriers such as fences are generally not recommended, since they all too often deteriorate, in the long term, requiring more regular maintenance.

However, they can be proposed on large linear areas in which migrations* are diffuse and where underpasses are widely spaced out.



② Different forms of collector obstacles. Source: M. Dwaller.



④ Example of a concrete edge. Source: Maibach.

(see sheet no. 21 "Rights-of-way/fences and barriers")

Underpasses

Several types of underpasses are possible. They generally consist of a series of prefabricated elements 1.5 to 2.5m long. Concrete frames are to be preferred and especially open structures (ground side), because they have the advantage of maintaining contact with the natural humidity and temperature of the substrate which are more conducive to the movement of amphibians and of wildlife in general. The use of closed frames will mean covering the bottom of the passage with a few centimetres of soil (to be used when laying each prefabricated element). The use of ducts should be avoided for these systems, because they are less conducive to crossing by amphibians (especially by urodela* which tend to climb along the walls and wander around the tunnels for days).

The structures are installed on a bed of 10 to 20cm of compacted non-gelling materials. The sides of the usual structures are filled 40cm thick (compacted layer of non-gelling materials). The passageway comprises a structural layer 0.8 to 1.2m thick above the structure to ensure its stability and durability (4). There are also structures whose thick walls (> 20cm) and ceiling (> 25cm) make it possible to limit the height of the cover.

The internal section of the structures must be greater than 0.75m² (except for the smaller two-way roads where the section of the structure may possibly be smaller depending on the context), but it must be adapted to the length of the underpasses.

In the international reference book, the *Hand book of road ecology*, the authors propose a decision-making typology integrating the shape and length of crossings. Without being a standard, this table gives a general trend which operators can use (see table below).

Shape	Size (w x H dimensions inside the structure)	Length of underpasses				
		20m	20-30m	30-40m	40-50m	50-60m
Frame	w x H (dimensions inside the structure)	1 x 0.75m	1.5 x 1m	1.75 x 1.2m	2 x 1.5m	2.3 x 1.75m

According to Hamer A.J., Langton T.E.S. & Lesbarrères D., 2015, *Making of safe leap forward: mitigating road impacts on amphibians*.

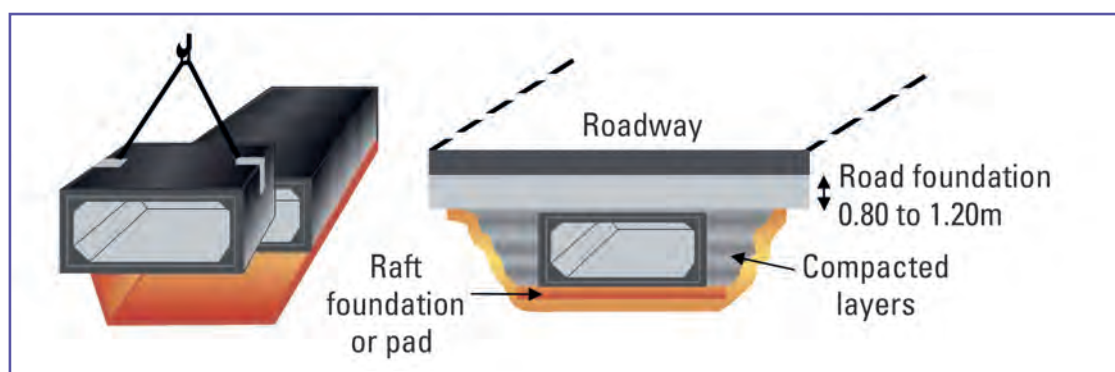

4 Schematic diagram of a framework structure consisting of a series of prefabricated elements placed on a thin concrete base. Source: Cerema.

The structures must be installed with a slope greater than 1% in order to ensure the evacuation of water. If the structure does not have a natural gravity outlet, a specific infiltration system must be considered. This is particularly the case when the entrance and exit structures are located below the natural ground (access via a funnel pit).

These systems are generally recommended on sections ranging from several hundred meters to one or two kilometres. The distance between each crossing structure must be approximately 30 to 40m. Non-dedicated structures of the waterway structure type may also be integrated into the system.

For the procession of species known as "pioneers" in generally open environments and temporarily in water (e.g. green toad, yellow-bellied toad, natterjack toad) or when migration corridors* are very diffuse (e.g. within a large forest area) and affect large sections (> 2km), the distance can be increased without however exceeding 100 metres. However, this choice will have to be specifically justified by the opinion of a specialist and by precise data on the monitoring of migratory routes, the standard spacing remaining a distance 30m to 40m.

■ **Advantages/disadvantages**

Advantages:

- highly effective for amphibians;
- may be used by all terrestrial small fauna;
- no major design problems, except for specific topography, flood zone, etc.;
- few weak points and low maintenance (especially with concrete or metal edges);
- easy water flow management;
- species can u-turn.

No major disadvantages.

One-way crossing system

This system is historically reserved for populations of amphibians whose migrations* are localised and relatively large (early reproduction and qualified as explosive such as the common toad, the common frog and the agile frog). It is a system that is less recommended nowadays, particularly because of its use restricted to practically one single group of animals. In some very specific cases and contexts, however, the choice of such a system may still be proposed, in particular when the crossings exclusively concern a migration route* for amphibians (e.g. forest path along a lake where only amphibians are likely to cross ⑤).

■ **Description**

The objective is to reduce wildlife vehicle collisions with amphibians on the migration route and to force them to use underpasses. Unlike the previous system, it consists of two separate, completely independent tunnels, the first for outward* migration and the second for return* migration.

On either side of the roadway, the system is composed of a collection barrier corresponding to a U-shaped gutter. Each gutter is installed along the whole of the amphibian movement

front (or at least on the busiest part). Each of the gutters is connected to one-way underpasses. For pre-nuptial migration* towards the aquatic reproduction site, there is therefore a tunnel that is completely separate from the second which, in theory, is used for the return of adults (post-nuptial migration)* and, in the summer, of metamorphs and/or juveniles.

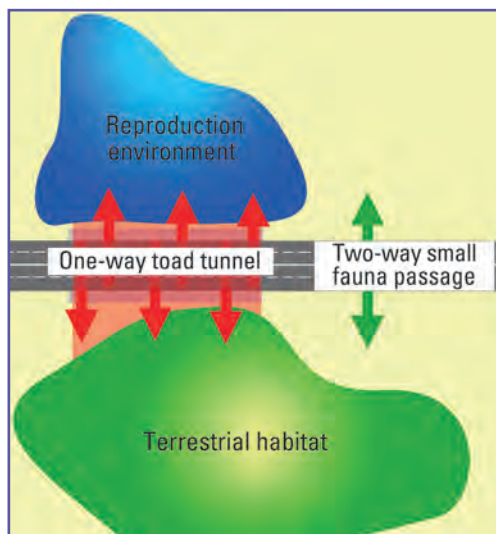

⑤ An example of a context where the infrastructure runs alongside the reproduction medium and where a one-way system is warranted. Source: Cerema.

■ **How it works (⑥ to ⑨ next page)**

When the amphibians migrate (either in one direction or the other) and arrive at the collection systems, they fall into the gutter. They then have no other solution (height prevents them from jumping out) than to follow the walls of the gutter to pits (or fauna exits, if they wish to turn back – see page 133) into which they fall. At the bottom of the pit (with a 45° incline to prevent them from injuring themselves while falling), which also corresponds to the entrance of the tunnel under the roadway, they can no longer turn around, so they have no other option but to use the one-way passage to escape. The pit could also be covered over 1.5m long with flaps to ensure maximum darkness and avoid draughts. The only light coming from the opposite exit then draws individuals more easily towards the exit of the structure.

When the infrastructure is sufficiently embanked, the exit of the structure is located at the natural ground level, otherwise amphibians exit via funnel pits pools to reach the natural ground level.

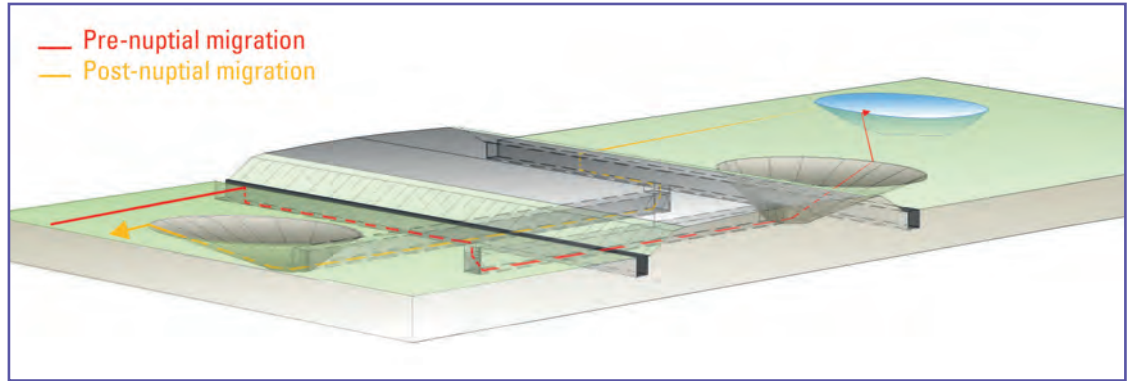

⑥ Schematic representation of a one-way crossing system and of the movement direction of amphibians. Source: Cerema.

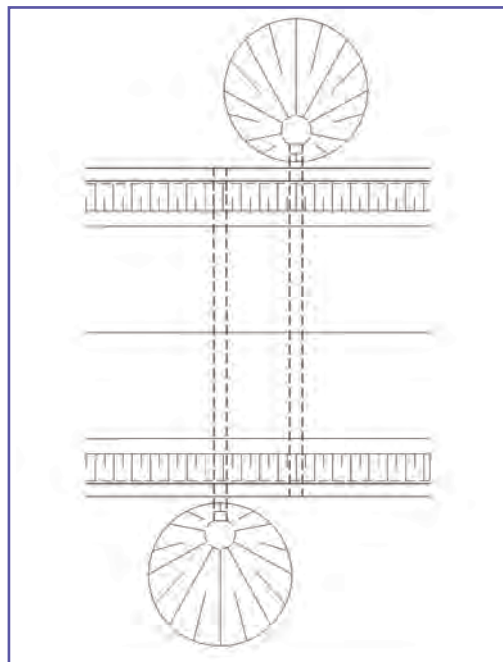

⑦ Plan view of a double conduit. Source: Cerema.



⑧ Larchant one-way crossing (77). Source: Cerema.

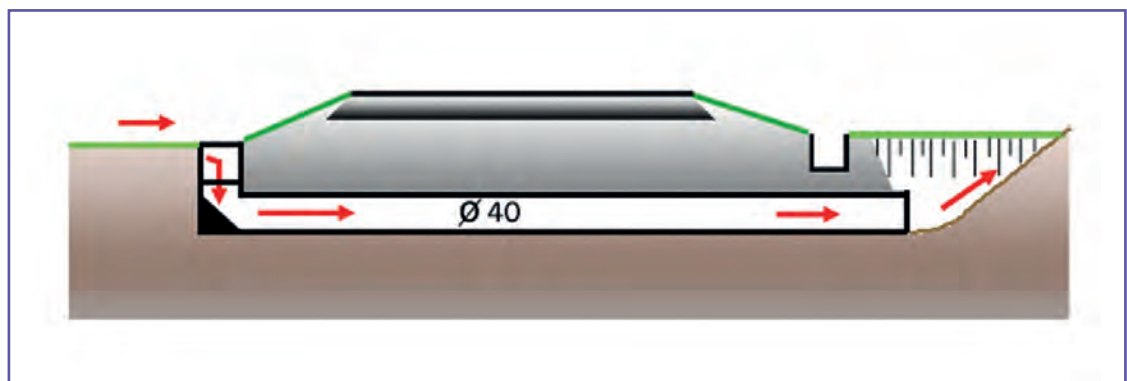

⑨ Cross-section of a one-way conduit. Source: Cerema.

■ Constructional specifications

Each gutter is made of concrete with minimum dimensions of 0.4m x 0.4m. The thickness of 5cm must offer sufficient resistance, particularly on small infrastructures, where vehicles parked on the edge of the road are likely to encroach on structures.

The gutters should be preferably installed on a bed of sufficient size to avoid compaction.

Unless a specific constructional system is provided, a minimum height of 1.2m must be provided between the conduit and the roadway. The crossings are installed over the entire length of the system with a regular interval of 30 to 40m between each conduit. These structures are set between 60cm and 1m below the level of the bottom of the gutter. The junction between the structure and the gutter is made by a 40cm wide "pit" with a 45° sloping concrete base.

In order to turn back amphibians and other animals who do not wish to cross, 1m wide fauna exits must be positioned at equal distances from the double conduits (the aim is to position them far from the entrances to the passages) (10).

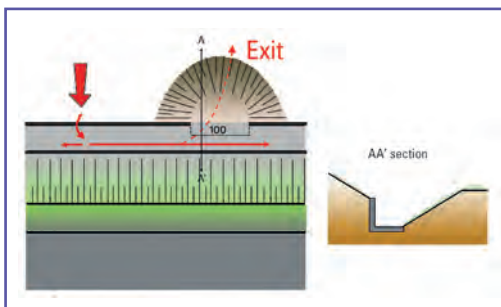

10 Plan view of an escape exit.
Source: Cerema.

There should be a slight slope in the gutters towards the pits and then towards the opposite exit to allow the water to escape. When exits are via a funnel pit, the system must also be fitted with a drainage device to prevent flooding at the exit (drainage pit, soak pit).

■ Advantages/disadvantages

Advantages:

- effective for amphibians;
- forces animals to cross.

Disadvantages:

- species using the structures in the opposite direction to the one designed (via the exit) can encounter difficulties and even fail to exit on the other side;
- it may prove difficult to control water in these structures. U-shaped gutters must not constitute surface water collection systems or be connected to the road sewerage system. The water must not stagnate there either (risk of drowning, laying). When the structure exits are via funnel pits (or ramps), the evacuation of water can be complicated;
- requires regular maintenance to ensure that vegetation and deposits do not build up in the system;
- these systems are used almost exclusively by amphibians for a short period of time. The size and accessibility of the structures are a real difficulty for other types of animals;
- the cost is usually higher than a two-way system.



The cost of a system comprising the guiding and crossing system is estimated between €400 and 1200/m for the equipped infrastructure.

This high variability is due both to the configuration of the site, the type of system, the materials used, the length of the infrastructure, but also the length of the crossing and the size of the structures.

In general, two-way systems are less expensive than one-way systems.



Particular attention must be paid to guiding systems to prevent them from creating traps for amphibians and/or small fauna (example: guiding system ending in a run-off water collector). The rainwater collection devices must therefore be separated from the guiding systems.



Guiding system leading to a drain.
Source: Jérôme Bacquaert, CD62.

The use of run-off collectors (road or natural water) must also not be accessible to amphibians and/or small fauna (or should at least have escape exits) to prevent them from remaining blocked and eventually dying there. This is often the case, for example, with U-shaped gutter devices.

Additional systems

- At the ends of the collection barriers, certain configurations require return guidance devices to prevent amphibians from crossing onto the roadway (12).



12 Return guiding system at the collector's ends.
Source: Maibach.

- When the structure is located below the level of the collector, very often, to have a sufficient roadway body, a capture pit equipped with gently sloping access ramps may be considered to lead the amphibians to the entrance of the passage (11).

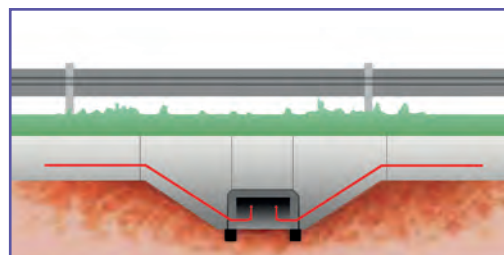

11 Schematic diagram of an access ramp to the passage.
Source: Cerema.



Structure equipped with an access ramp. Source: Maibach.

- To force amphibians to use the structure, additional guidance devices perpendicular to the walls can be added to the entrance of the structures (13).



13 Guiding system to facilitate use of the passage by amphibians. Source: Cerema.

• When a secondary access road joins the main infrastructure and intercepts an amphibian guiding system (fencing or wall), the infrastructure access road may act as an entry point for amphibians. In this case, care must be taken

to ensure the passage of amphibians under the secondary road by installing a box culvert* or an openwork structure (prefabricated structure, structure with cattle grid) connected to the guiding system (14).

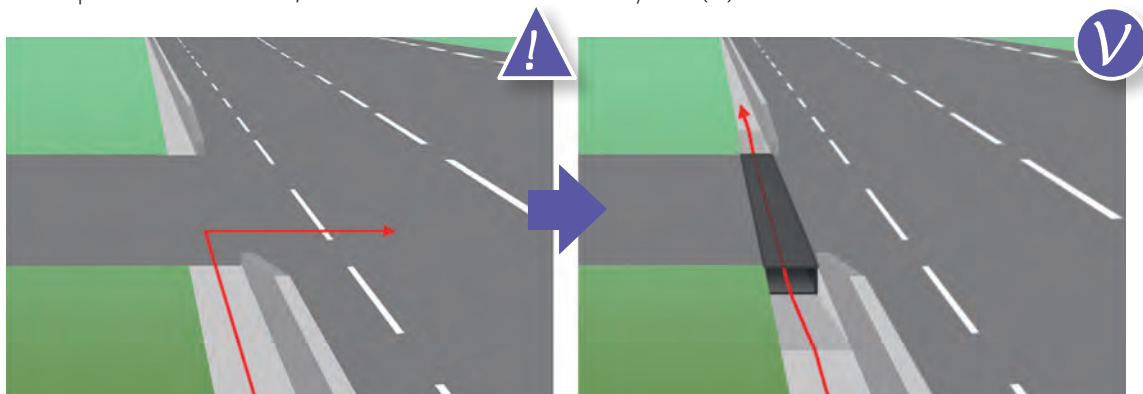

14 System for crossing a roadway perpendicular to the main infrastructure preventing amphibians from accessing the latter. Source: Cerema.

Passages may be a hazard to road users and therefore require additional protections such as safety barriers. In the context of a two-way crossing system, a collector in the form of a low concrete wall (15) can also be envisaged to guide the amphibians and act as the safety system.



15 Concrete wall guiding amphibians and securing users. Source: Cerema.



With regard to conventional railways, it is possible to develop empty spaces under the tracks. A stopper guides the animals moving on the rail skid. The distance between rail passages is 15 to 25m.

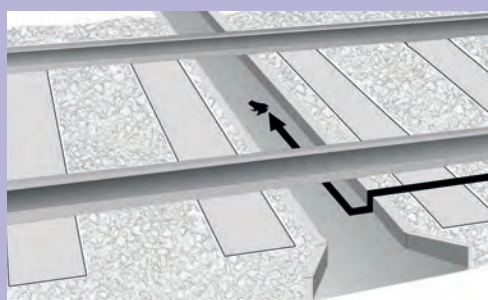

Rail crossing system for amphibians. Source: Cerema.

On road infrastructures, passages with holes on the roof, throughout the length of the crossing, or at the level of the central reservation, are not recommended in particular to avoid the input of water with a high concentration of salts, resulting from salting operations. This water is highly toxic for amphibians. The attractiveness of light to amphibians should be limited to the tunnel exit on the other side of the roadway.



Open-worked crossing structure. Source: Environment committee, municipality of Ahuy.

Canopy passages

In France, species likely to use canopy systems are few and far between, and the experience gained mainly concerns remedial measures on small infrastructures, especially installed to allow squirrels and other small arboreal mammals (martens, shrews, etc.) to cross the infrastructure

(see fact sheet no. 18). These are mainly roping systems.

Experiments abroad show however that there are other ways using light metal structures or nets supported by a metal frame (see photos above) or cables.



The cost of a canopy passage consisting of a metal frame is approximately €30,000 to 45,000 excluding VAT for a 20m passage.



Canopy passage with metal structure. Source: Animex.



FACT SHEET

14

How to develop common small fauna passages?

Types and sizes of passages

There are several types of common small fauna structures. They usually consist of concrete but also metal conduits installed in the embankment (see table below).







These structures are quite effective and relatively inexpensive.

Even though there are several types and dimensions for all these structure categories, it is recommended to use open or closed box culverts* **1 to 1.5m wide and 1m high**. The dimensions are however to be adapted to the length of the crossing (see table below).

Most frequent cases

Length of the crossing	20-30m	30-50m	> 50m
Recommended width	> 1m	> 1.5m	> 2m
Recommended height	> 1m	> 1.5m	> 1.5m
Section	> 1m ²	About 2m ²	3m ²

In some cases, when the covering layer is thin (embankment), the height of the structure could be smaller without being less than 0.70m, except in exceptional circumstances.

	Type	Advantages/disadvantages	Size/cost ¹³
Open concrete box culverts on support	 <p>Source: Christian Bulle (CD Doubs).</p>	Used to maintain natural ground.	$l^{14} = 1 \text{ to } 1.5\text{m} \times H^{15} = 1\text{m}$ €300 to 600/m excluding VAT
Closed box culverts	 <p>Source: Cerema.</p>	The structure needs to be filled with a layer of soil to ensure natural ground. Make sure there is a minimum height between the reconstituted ground and the height of the duct.	$l = 1 \text{ to } 1.5\text{m} \times H = 1\text{m}$ €400 to 800/m excluding VAT
Concrete ducts	 <p>Source: Cerema.</p>	The structure needs to be filled with a layer of soil to ensure natural ground. Make sure the duct is oversized to reach the minimum height between the reconstituted ground and the height of the duct.	$\varnothing = 1\text{m}$ €300 to 600/m excluding VAT
Ovoid conduits	 <p>Source: Cerema.</p>	The structure needs to be filled with a layer of soil to ensure natural ground. The lower part of the duct needs to be factory-concreted twenty or so centimetres deep to allow movement of wildlife (pay attention to the connection of this section with the natural ground).	$H = 0.60\text{m} \times l = 1\text{m}$ €300 to 600/m excluding VAT
Duct in recycled high density polyethylene	 <p>Source: Cerema.</p>	The structure needs to be filled with a layer of soil to ensure natural ground. Without a concrete structure head, the connection with the fencing is difficult and rarely sealed. Make sure the duct is oversized to reach the minimum height between the reconstituted ground and the height of the duct.	$\varnothing = 1\text{m}$ €200 to 500/m excluding VAT
Dome	 <p>Source: Maibach.</p>	Used to maintain natural ground but maximum height at the centre of the structure only.	If this type of structure can be found, this reference is apparently no longer available.

¹³ Cost of the supply and installation.

¹⁴ W: width.

¹⁵ H: height.



Metal duct



Source: Cerema.



The structure needs to be filled with a layer of soil to ensure natural ground.

These structures unfortunately show corrosion issues in the long term.

Choice of location

The structure is usually positioned 0.4m to 1.2m under the roadway, depending on the presence of a transition slab or on the type of structure (reinforced or not).

It is designed on the basis of the combination of prefabricated elements around 2m long.

The structure should have a slight slope (> 1%) to evacuate water.

The structure must be placed on the top of the embankment for two reasons (❶):

- reduce the crossing length for wildlife,
- better guide wildlife by the fencing when it is located, as recommended, on top of the slope (access of green rights-of-way to wildlife).

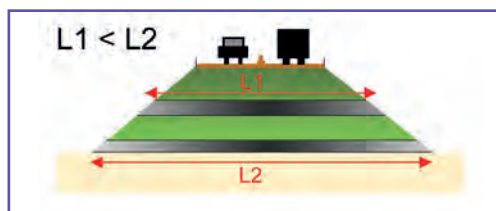

❶ Schematic diagram of the layout of a small fauna structure in an embankment. The structure should be positioned as high as possible in the embankment to reduce the crossing length. Source: Cerema.

Otherwise, when fencing is located on the top of the slope and the entrances to the structures are at the foot of the embankment, guiding is less effective (❷).

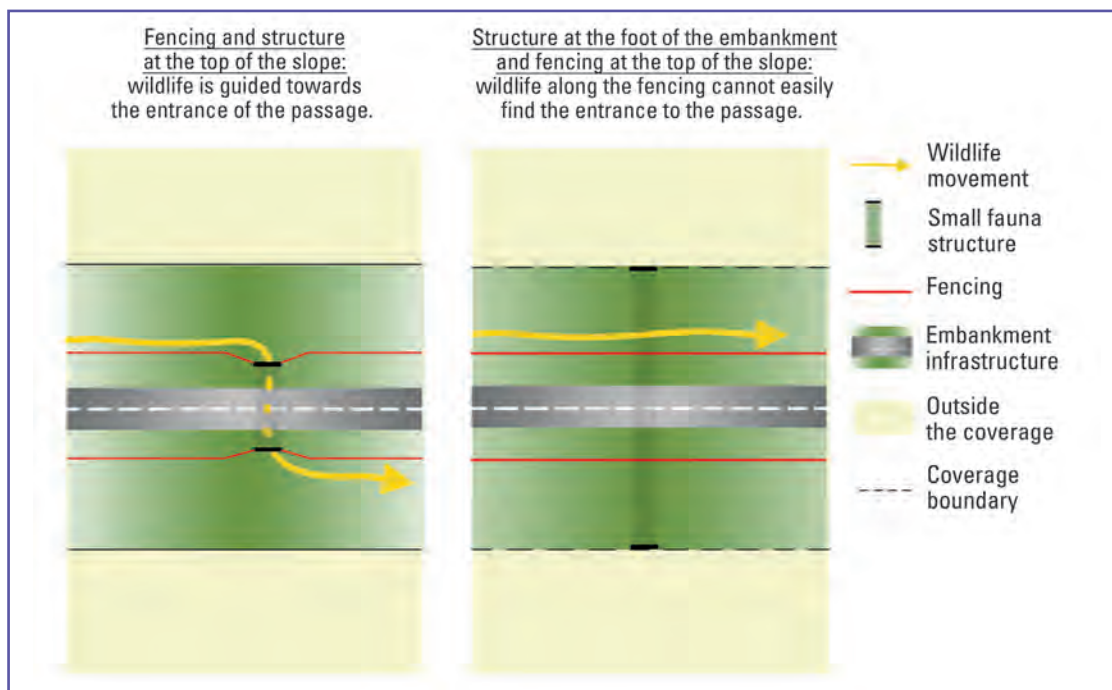

❷ Schematic diagram used to view the benefit of positioning fencing and small fauna passages at the top of a slope. Source: Cerema.

When the structure is beneath the natural ground level (excavated or level road) the construction of and access to a small fauna structure requires:

- either the construction of a funnel pit (③);
- or structures with a high gradient slope in the first metres to go deep enough under the infrastructure (one single opening point if the profile is mixed (④) otherwise both structure heads should be sloping (⑤)). When both entrances are sloping, to avoid surface water running off into the structure from the entrances, an earth mound must be created as an obstacle*.



③ Funnel pit next to a small fauna passage of an infrastructure section located on the natural ground level. RD 16 (CD57). Source: Cerema.

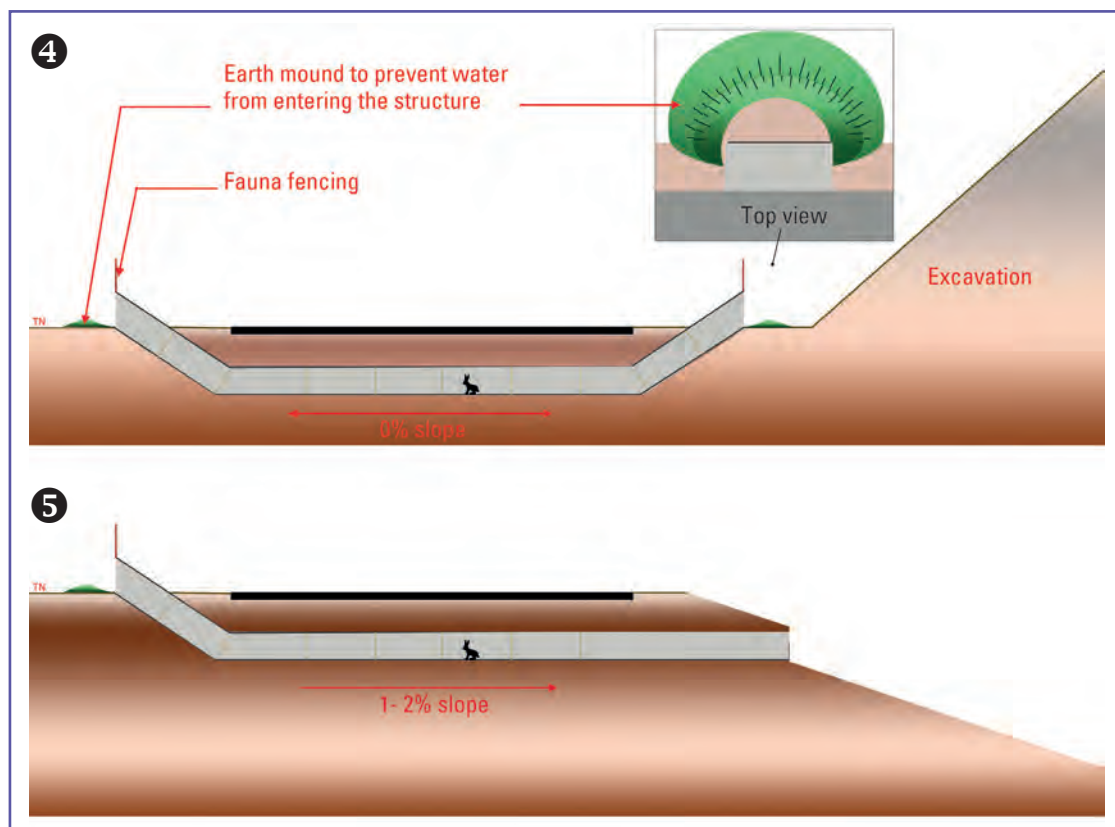

Cross-section of a small fauna passage with two sloping entrances ④ (or one ⑤) when the infrastructure is on the natural ground level. Source: Cerema.



Sloping small fauna passage on an infrastructure located at the natural ground level.
 Source: Cerema.



- or narrow access ramps, parallel to the infrastructure (6), when coverages are limited or the topography is difficult (steep slope at the exit of the passage, cutting).

In some cases, a retaining wall (or blocks 7) is required to hold back the materials liable to collapse towards the structure entrance.

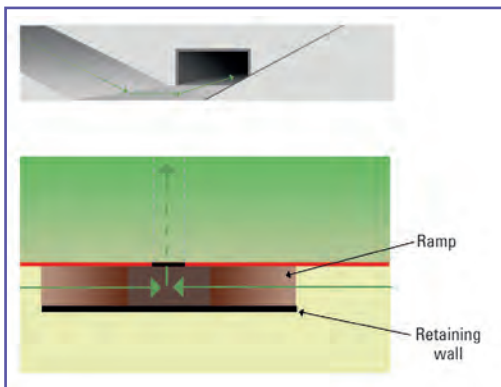

6 Schematic diagram of an access ramp to the small fauna passage. Source: Cerema.



7 Access ramp protected by a masonry wall on the side of green rights-of-way. Source: Cerema.

Access ramps can also be replaced by sloping structure heads which will avoid gullyng of fines towards the passage entrance. (8 and 9 next page). Efficacy is however reduced by the increased length of coverage, reduced light and lack of visibility at the exit.



8 Example of a small fauna passage with a sloping structure head parallel to the infrastructure.
 Source: Cerema.

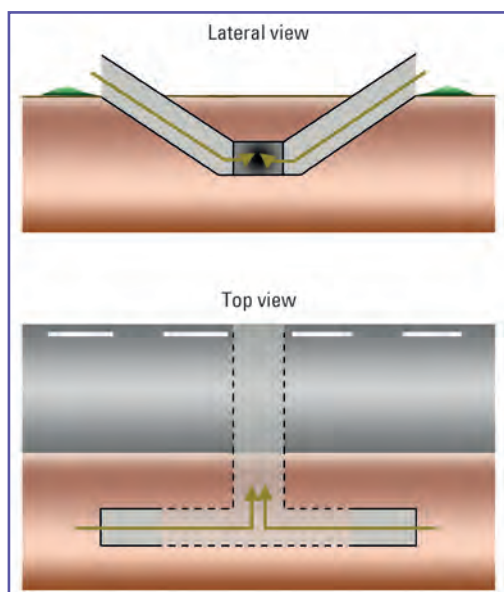

⑨ Schematic diagrams of a structure with an entrance parallel to the infrastructure, sloping down to reach the depth of the passage beneath the infrastructure. Source: Cerema.

When structures are beneath the natural ground level and the soil does not filter enough, there is a high risk of flooding of the structures or entrances (⑩). To avoid or at least limit this situation, it is necessary to create a drainage ditch or soak pit at the passage entrances (⑪).

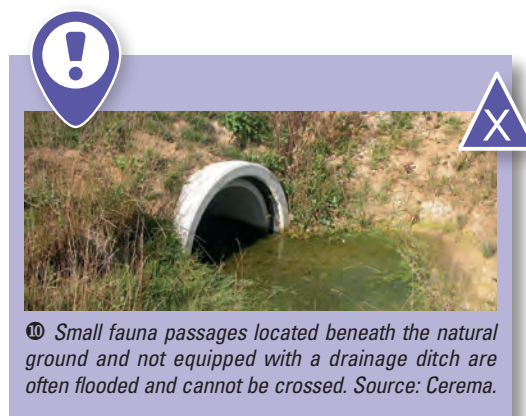

⑩ Small fauna passages located beneath the natural ground and not equipped with a drainage ditch are often flooded and cannot be crossed. Source: Cerema.

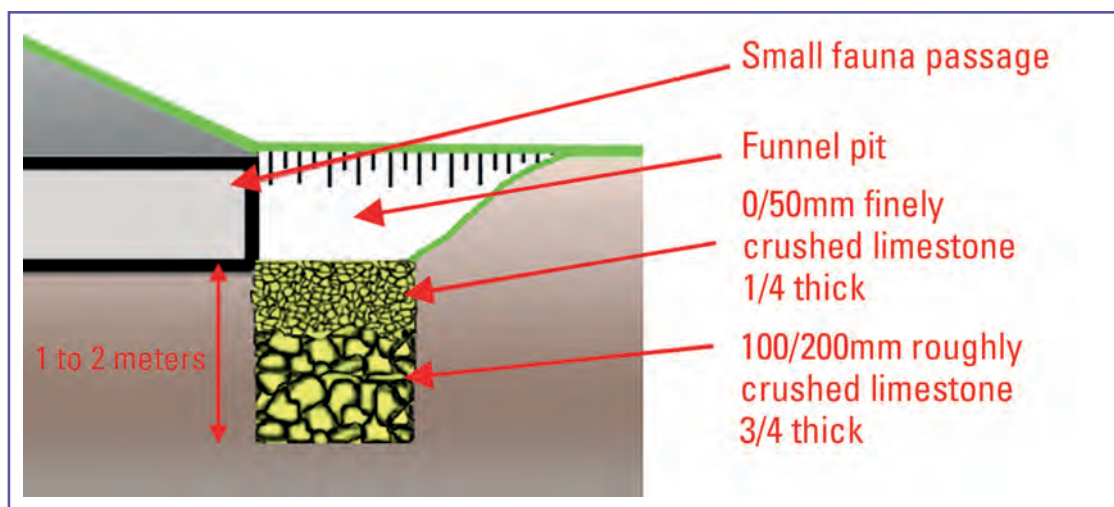

⑪ Principle of a drainage ditch at the entrance of a small fauna passage. Source: Cerema.

There must be no obstacles* at the structure exit, and no ditches that are often dug at the coverage boundary. Such features can trap or prevent small fauna from crossing. The possible solutions are: an access ramp (⑫), piping of the ditch (⑬ next page), a funnel pit (to reduce water depth) or, when there is low water flow, filling with draining materials (⑭ next page) (perhaps covered with a geotextile and finer materials).



⑫ Wooden platform used to cross a ditch. Source: Cerema.

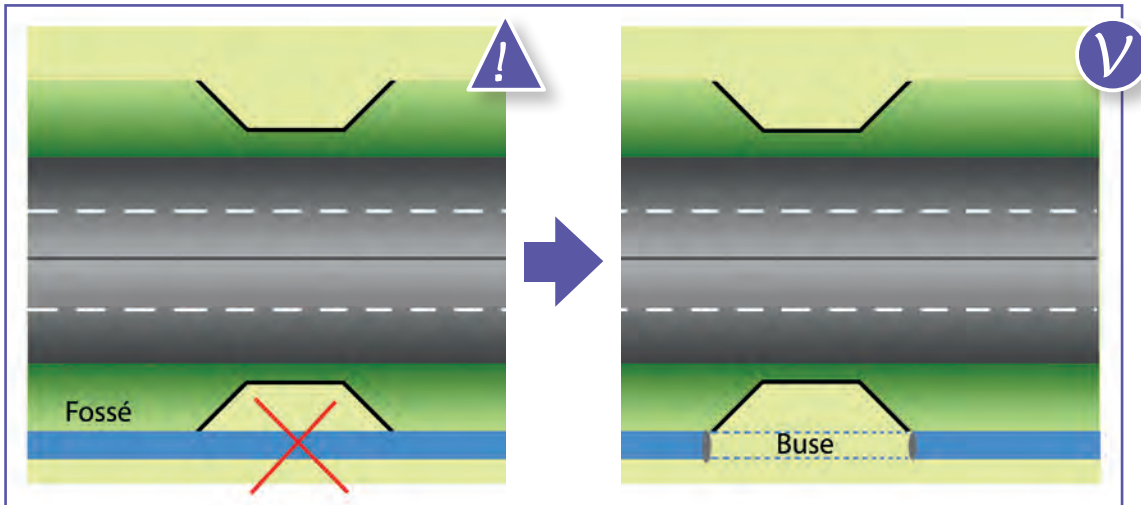

13 Schematic diagram of the installation of a duct to remove the obstacle created by a ditch located at the exit of a small fauna passage. Source: Cerema.



14 Schematic example of a ditch crossing system by filling with draining materials. Source: Cerema.

Passage ends equipped with structure heads (prefabricated or made in concrete formwork) are used to connect to the natural ground and fencing, maintain soil and reduce subsequent maintenance (15).

The presence of a return or "wing" wall (16) can slightly reduce the crossing length and help guiding of the animals to the structure entrance.



15 Structure head in concrete formwork. Source: Cerema.



16 Structure head with open walls. Source: Cerema.

It is important to check that there is no step at the structure entrance (17). While the existence of step is not a problem for large species, it can cause problems for smaller species (hedgehogs, etc.).

To avoid the development of vegetation, it is possible to extend the foundation raft* outside the structure (18) and cover it with soil. When it is created in the embankment slope (to reduce the crossing length), the foundation raft* can be extended by a gently sloping masonry ramp which will also be covered by a layer of soil. To improve the hold of this layer of soil, it is

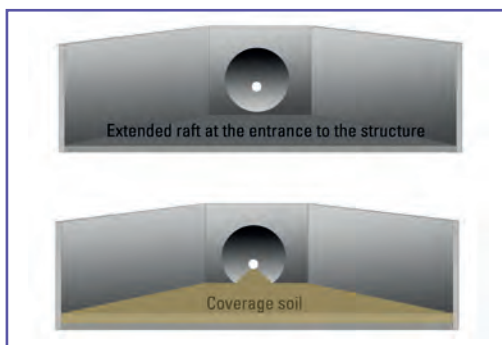

18 Schematic diagram of a foundation raft at the exit of a structure. Source: Cerema.

Additional developments

When the structure does not hold back the natural ground (closed box culvert*, duct), it is recommended to fill the structure with a 5-10cm layer of soil. To make things easier, it is recommended to fill each



Implementation of a layer of natural materials. Source: Barb BEASLEY, Association of Wetland Stewards for Clayoquot and Barkley Sounds.



17 Presence of a step at the entrance of the passage preventing access to smaller animals. Source: Cerema.

preferable to seal the blocks into the masonry while leaving some of it (4-5cm) apparent to form rough edges (19).



19 Construction of a masonry ramp before being covered with soil. Source: Vinci Autoroutes/ASF network.

element as the installation progresses, especially if the structures are small in size. Otherwise, once all the elements are in place, it would be difficult to fill the parts most distant from the entrances.



Manual implementation of a layer of soil inside a duct. Source: Vinci Autoroutes/ASF network.

Even they are often small in size, structures can benefit from additional developments to make them more attractive. Swaths* against the walls or a few piles of blocks scattered in the structure can create shelters for small animals and marking points.

Connection to landscape structures

Often neglected, reconnection of small structures to landscape structures by appropriate positioning is necessary to increase the efficacy of the passage. If a structure separated from natural continuity cannot be avoided, a favourable landscape development should re-establish the connection between the initial ecological corridor and the structure (e.g. grassland and additional planting). 20

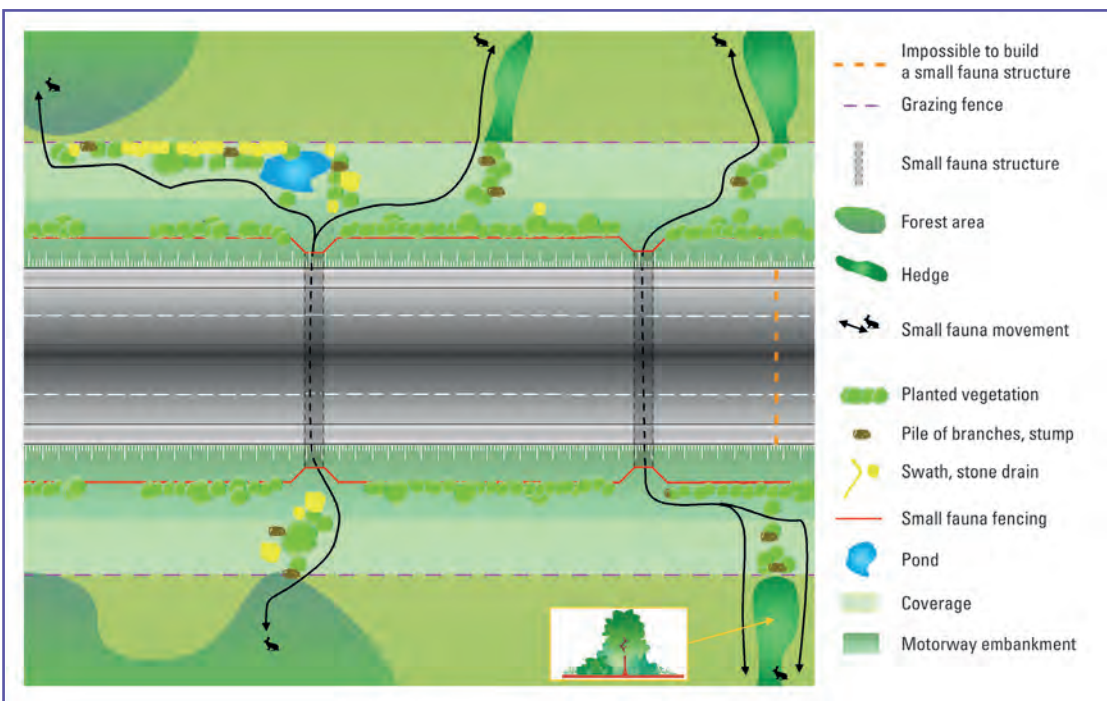



20 Principle of merging structures with existing vegetation structures. Source: Cerema.



Passages and developments for small fauna?

Objective: a crossing possibility every 300m, taking into account all crossing possibilities

- 1 Take into account all fauna passages that are already crossing possibilities for small fauna. 
- 2 Adapt waterway structures so they can be crossed by small fauna. 
- 3 Create or adapt additional crossing possibilities next to the major small fauna issues (e.g. amphibians). 
- 4 Depending on all the previously installed systems, add additional small fauna passages or adapt restoration structures (agricultural, pedestrian) so that wildlife is given the possibility of crossing every 300m on average. This spacing can vary slightly to factor in landscape features (positioning next to the existing ecological network).

Special recommendations

..... For waterway structures, provide for:

- a bench with a minimum width of 50cm on each bank;
- minimum headroom* of 0.7m.

..... To adapt agricultural or pedestrian restoration small fauna restorations, provide for grass verges of 1 to 2m.

..... For additional small fauna passages, structures of at least 1m to 1.5m wide by 1m high or more are recommended when the crossing is long (> 30m).



*Small fauna passage.
Source: François Nowicki.*

Group of species	Species	All fauna passage				Small fauna passage									
		Exceptional		Remarkable		Ordinary		Structure not dedicated to fauna equipped with grassy benches*	Canopy passage	Amphibian tunnel (two-way)	Small waterway structure equipped with a bench*	Dry talweg structure	Single structure		
		Overpass (covered trench, tunnel)	Underpass (viaduct)	Overpass	Underpass (viaduct)	Overpass	Underpass (If H > 4m)	Overpass	Underpass (If H > 4m)	Overpass or underpass					
Ungulates	Deer	●	● (If H > 4m)	●	● (If H > 4m)	○	○ (If H > 4m)	○	○ (for underpass only if H > 4m otherwise x)	○	x	x	x	x	x
	Roe deer, chamois	●	●	●	●	●	●	○	○	○	x	○	○	○	○
Carnivores	Wild Boar	●	●	●	●	●	●	○	○	○	x	○	○	○	○
	Brown bear	●	●	●	●	●	●	○	○	○	x	x	x	x	x
	Lynx	●	●	●	●	○	○	○	○	○	x	○	○	○	○
	Wolf	●	●	●	●	●	●	●	●	●	x	x	x	x	x
	Fox	●	●	●	●	●	●	●	●	●	x	●	●	●	●
	Wild cat	●	●	●	●	●	●	●	●	●	x	●	●	●	●
	Badger	●	●	●	●	●	●	●	●	●	x	●	●	●	●
	Otter, European mink	○	● (Mixed waterway) ○ other	○	● (Mixed waterway) ○ other	○	● (Mixed waterway) ○ other	○	○ (Mixed waterway underpass) ○ Overpass	○	x	○	○	○	○
	Stone marten Weasel	●	●	●	●	●	●	●	●	●	○	●	●	●	●
	Other small mustelid	●	●	●	●	●	●	●	●	●	x	●	●	●	●
Genet	●	●	●	●	●	●	●	●	●	?	●	●	●	●	

Lagomorphs	Hare		●			●	x	○	○	○	○	○	○	
	Rabbit		●			●	x	○	○	○	○	○	○	
Insectivores	Hedgehog		●			●	x	○	○	○	○	○	○	
	Shrew		●			●	x	●	●	●	●	●	●	
Rodents	Red squirrel		●			●	●	x	x	x	x	x	x	
	Dormouse		●			○	●	x	x	x	x	x	x	
	Mouse		●			●	x	●	●	●	●	●	●	
	Vole		●			●	x	●	●	●	●	●	●	
	Beaver	○	○	(Mixed waterway) ● ○ other	○		○	x	○	○	○	○	○	○
		●	●	(Mixed waterway) ● ○ other	○		○	○	(Mixed waterway) underpass ● ○ Overpass					
Reptiles	Snake		●			●	x	○	○	○	○	○	○	
	Lizard	●	●			●	x	○	○	○	○	○	○	
		○	○			○	x	○	○	○	○	○	○	
Terrestrial invertebrates	Amphibians	○	●			○	x	○	○	○	○	○	○	
		●	●			●	○	(Mixed waterway) underpass ● ○ Overpass						
		○	○			○	x	○	○	○	○	○	○	
	Dry habitat species	●	●			●	x	○	○	○	○	○	○	
Wetland habitat species	●	●			●	x	○	○	○	○	○	○		
Bats	●	●			●	○	○	○	○	○	○	○		

● Optimal solution
○ Likely to be used depending on local conditions and size
○ Exceptional use also depending on the size of the structure

? Unknown, more experience required
x Inappropriate

2 Fauna passages on existing infrastructure – upgrading

Upgrading* of an infrastructure depends on a multi-level diagnostic (ranging from that of the local area to that of the infrastructure or of the fauna passage) to best meet the restoration objectives of the ecological network. Although it is necessary, the diagnostic methodology must not be standardised or imposed as it must respond to local issues. The methods will therefore vary, depending on:

- issues of the territory, target species and environments to reconnect, taking into account the expansion of species such as deer;
- the type of infrastructure;
- the extent of the study area;
- the available data;
- constraints imposed by the contracting authority (namely financial and time-related).

However, it is recommended that the work complies with two major stages:

1. An *ex-situ* spatial analysis at a macro level using GIS tools and reference documents produced by public territorial development policies (SRADDET, SRCE, ScoT, etc.).

2. The implementation of an ecological audit (species, environments) using local studies that result from the first stage, knowledge provided by local stakeholders, diagnostics of structures where relevant to assess existing crossing possibilities.

It should be noted that a diagnostic of the restoration of the ecological network next to

the existing infrastructure is quite easy to set up but requires a long study period that needs to be anticipated. Beyond the implementation of works for a given project, the diagnostic can prioritise useful issues for program long-term works.

For the upgrading* of infrastructure, several types of works can arise:

1. **The adaptation of existing structures;** with the help of very light structures (case of a floating or corbelled* bench*) and very consequential techniques (widening of an existing civil engineering structure);

2. **The construction of new structures** aimed at small and large fauna (see previous chapters);

3. **The development of the infrastructure** in the absence of a transparency structure (devices to alert, scare or guide wildlife, repositioning of fencing with respect to passage possibilities).

In all cases of infrastructure upgrading*, it is necessary to recall the necessity of compliance with regulations on nature protection (Water Act, law on protected species, Natura 2000* assessment file, etc.) and safety and access issues related to the facilities and structures.

Additional information is available in the SRCE "*Rapport technique SRCE et requalification des infrastructures*", published by Cerema. (2019).

Development *2.1* and/or upgrading of existing structures

In some cases, existing civil engineering structures are correctly positioned next to an ecological network but their size or configuration no longer encourages wildlife to cross or only in a random and fragmentary way. There are solutions available to make this type

of structure workable using different techniques at variable costs.

While such techniques exist, several factors (control of coverage, access, existing network, etc.) often make their implementation much more complex than in a new operation.



Stone marten on corbelling. Source: Jean-François Bretaud.

How to improve the functionality of existing fauna passages?

Some fauna passages, although well positioned with respect to the existing ecological network, are not very functional given their configuration (inappropriate surfacing, used for another purpose, lack of maintenance) or are undersized compared to the scale of the corridor they are supposed to restore. In both cases, improvement

possibilities exist. It is necessary to **refer to the construction standards laid down in part one of this document** (see chapter on new constructions).

The next two paragraphs show what can be done in terms of upgrading* existing fauna passages.

Reinforcement of planting, management of vegetation, removal of light pollution, etc.

Simple and often inexpensive work can significantly improve the functionality of these structures:

- by diversifying environments through the implementation of swaths*, modelling topsoil, improving the vegetation development of the structure, especially by promoting the connection to transversal and longitudinal corridors and planting appropriate species for fauna. In this case however, it is important not to put pressure on fencing by placing fruit trees (wild apple, fig, etc.) too close to it. Fruit falling on the infrastructure could lead some species (e.g. wild boar) to try even harder to reach them and therefore damage the fencing;
- by controlling the quality of vegetation already present by clearing or selecting, by balancing the different layers (herbaceous plants to trees). On all fauna overpasses, the objective is usually, after intervention, to create an open herbaceous area in the middle of the structure, bordered by

two corridors of shrubs along the screening parapets. For smaller structures, priority should be given to clearing access to the passage;

- by blocking light wells (❶) sometimes present on structures to limit noise disturbance created by traffic and avoiding the build-up of waste under the structure. This measure can be adapted if, locally, the benefit of light on plant life on the structure or on its temperature (reduction of the tunnel effect) is observed.



❶ Example of an underpass with light well.
Source: Cerema.



Renovation of a fauna passage on the A84 (35)

This 20m wide fauna passage located in the Rennes forest on the A84 (DIR Ouest network) was, except for a pedestrian track, practically overgrown with brambles and gorse (see 1). An initial photographic study had shown that the passage was used by few species (wild boar and roe deer only) and that the passages were mainly confined to the pedestrian path.

2m were cleared across the pedestrian path to improve transparency (see 2). A more drastic clearing attracted species at more regular intervals (at least one passage every two days, all species put together) (see 3).



1 View on the overgrown fauna passage. Source: Cerema.



2 View on the partially cleared passage. Source: Cerema.



3 View from the cleared passage over 6m wide. Source: Cerema.

Widening of overpasses

Structures with an old design (2 next page) and undersized in view of local issues can be widened by the construction of a new parallel structure connected to the existing one (in this case, it is necessary to comply with design and development rules for new structures).

The use of this technique requires considerable care during the works phase to protect the existing

structure when building foundations or the deck on the new structure but also on the seal when connecting the existing to the new structure. The general development of the new all fauna passage is redesigned where possible with the addition of topsoil, new plants and the laying of swaths*. It is therefore advisable to ensure that new loads are compatible with the resistance capacity of the older structure.



Widening of the fauna passage of the la Lande forest A10 (17) ASF/Vinci Autoroutes

As part of the Paquet vert autoroutier* (2010–2012), ASF widened the overpass of the La Lande forest to meet the demands of species movements, especially large fauna. A new 590m² deck was laid with supports on the bank and a central reservation was built without sectioning the A10 (see illustration ③ and ④). This work increased the width of the structure from 3m (②) (in 1981, when the motorway was built) to 18.5m (see illustration ⑤).



② Initial overpass.
Source: ASF/Vinci Autoroutes.



③ View of the piers.
Source: ASF/Vinci Autoroutes.



④ Structure under construction.
Source: ASF/Vinci Autoroutes.



⑤ View of the completed structure.
Source: ASF/Vinci Autoroutes.



Deer, wild boar, roe deer crossing the passage. Source: FDC 17/VINCI Autoroutes - ASF network.



The operation implemented on the A10 motorway cost approximately 1.5 million euros.

FACT SHEET

16

How to promote the passage of small fauna on existing structures not dedicated to fauna?

When structures not dedicated to fauna are located in a high-issue area, environmental upgrading* of an infrastructure can be based on those existing structures, by changing their initial purpose so that they become fully or partly conducive to crossing by wildlife.

Reconversion of a structure has the considerable advantage of being less costly than the construction of a new structure. The function of the structure for wildlife does depend however on the level of upgrading* possible, conditioned by:

- the initial width of the structure and in particular the available space that can be left to wildlife;
- the scale of existing human disturbance (traffic, noise, smells, etc.).

On overpasses, it is also necessary to check:

- the structure's capacity to bear the weight of a layer of topsoil;

- the possibility of installing a screening parapet (wind resistance);
- according to the scale of the renovation, any structural and sealing issues that can arise (water seepage due to roots, etc.).

If, in a new project, the creation of mixed fauna and road structures is not acceptable, subject to exceptions (see fact sheet no. 12), as part of the upgrading* of an infrastructure, these provisions can be adapted, as improvement possibilities are often very limited. All fauna passage possibilities must therefore be examined. Under certain conditions, especially where traffic is low, the development of structures bearing a small surfaced road can be envisaged. In this case however, it is not recommended to favour large fauna species so as not to create accident-prone situations, especially on potentially high speed roads. This type of development, in all cases, requires balancing traffic and road safety requirements with wildlife movement.

Development of grass verges for small fauna on or in low traffic structures

Required conditions

The aim is to create planted strips on either side of the road (or on one side only if there is not enough space).

The development of this type of structure, while being less costly than the construction of a new structure, is not insignificant.

Besides complying with the constructional provisions related to the durability of the civil engineering structure (see above), it is necessary to factor in the elements that can optimise the operation of the structure:

- 30-50km per hour speed limit on low-traffic sectors (fewer than 1,000 vehicles per day);
- possibility of creating quite wide benches* (1 to 2m) with enough topsoil to grow herbaceous plants (20cm) (especially on overpasses);
- possibility of connecting benches* to a "natural" continuity;

- possibility of installing screening parapets adapted to the structure on overpasses.

Indispensable support measures

- insertion of a traffic calming device or road user information;
- introduction of a maintenance charter with the road manager.



Development of pavements on the PS 49/19 (A71) in Salbris (41) to make them suitable for the crossing of small fauna. Vinci Autoroutes - Cofiroute

Installation of two grassy benches* supported by kerbs.

Installation of screening parapets on each side of the road 1.4m high.

Installation of stacks of branches.

Installation of speed cushions (speed humps) at each entrance to the structure and alternating traffic with a limit of 50km per hour defined with the local municipality.

Roads and grassy pavements are managed by the municipality. The motorway operator is responsible for fencing, safety devices and the structure.



View of the structure before and after upgrading*. Source: Vinci Autoroutes - Cofiroute.

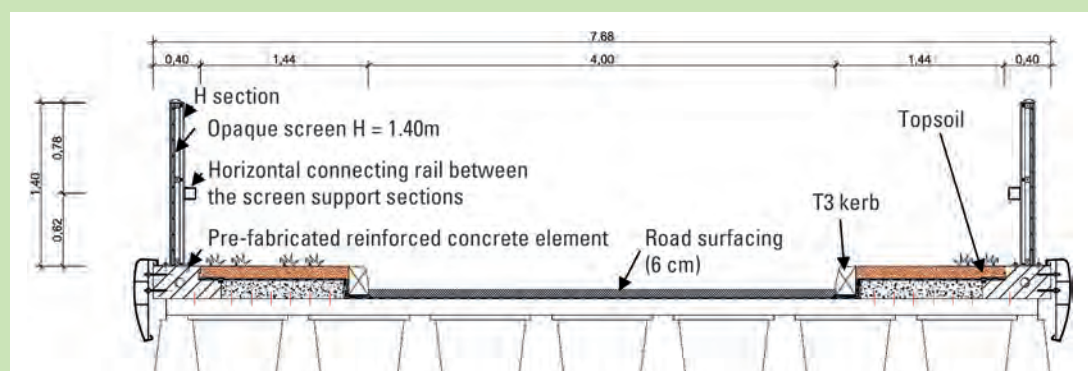

Schematic diagram of the development. Source: Vinci Autoroutes - Cofiroute.



The operation, implemented on the A10 motorway, cost approximately 1.5 million euros (2018).

Transformation of a non-dedicated structure into an all fauna passage

The development of this type of structure requires following the same principles as for the development of grass verges for small fauna (see previous chapter). Given the areas and widths available, development possibilities are however more extensive for an all fauna crossing, especially when it is an overpass (shrubby vegetation, lawn, additional habitat, etc.).

For overpasses, it is also necessary to check whether the new loads imposed on the structure of the structure are compatible with its load-bearing capacity and its durability.

If the transformation of the structure is carried out while maintaining human use, the "all fauna" purpose of such a structure requires limiting this use to low-traffic restorations (see insert on the following page).



Development of a mixed forest/fauna passage on the RN184

The RN184, a dual carriageway, cuts the biodiversity reservoir* of the Isle d'Adam state forest (Val d'Oise - 95) identified by the SRCE. The objective of the DiRIF was to redevelop the existing bridge to make it an attractive mixed passage for small and large fauna, while maintaining its use for human activities.

The structure is 16m wide. 11m of it are dedicated to fauna (vegetation, swath*) and to a sandy bridle path. The remaining 5m are reserved for road traffic (surfaced road).

The project designed by OGE (V. Vignon) was submitted to a technical committee bringing together local authorities, associations and institutions, in order to involve all stakeholders to take into account the needs related to each use and define the adjustments aimed at reconciling them.



View of the structure before works.
Source: Vincent Vignon, OGE.



View of the structure after works.
Source: Vincent Vignon, OGE.



Wall lizard on the swath from the first season after the works.
Source: Vincent Vignon, OGE.



€ Cost of the development: €710,000 (2016).



Conversion of the Bauxite road restoration into a Mixed Passage A9 motorway (34). ASF/Vinci Autoroutes



Before



After

Feedback from wildlife management and monitoring on the Vinci Autoroutes network (June 2016) shows that **this type of structure is not suitable for large fauna and not very effective for medium-sized wildlife**. This would be due to the significant visual and noise disturbances inherent in this type of structure. The same findings show that common species that are not very shy and adapted to humans are the ones that most frequent these passages (hedgehog, marten, rabbit, water rat). This type of development is therefore not recommended in the event of high-issue ecological networks.

Creation of a small fauna bench in existing waterway structures

In many cases of infrastructure upgrading*, the restoration of the ecological network for small fauna requires the development of existing waterway structures, even small ones.

Upgrading* operations on waterway structures for terrestrial fauna benefit in particular from the recent regulatory obligation to restore fish continuity on list 2 category rivers and on list 1 category rivers, when improvements are scheduled.

Watercourses classified under L214-17 of the French Environmental Code*, and more particularly in list 2, therefore constitute opportunities for the upgrading* of waterway structures for crossing by terrestrial fauna in addition to the regulatory obligation related to fish.

In waterway structures, the proposed improvements depend on the type of structure (construction materials), its dimensions and in particular its

section (the development must not call into question its hydraulic capacities) as well as the target species for which the development is built.



The regulatory framework for restoring the ecological network is based on two lists of watercourses, defined by Article L214-17 of the French Environmental Code*:

- list 1, which is intended to preserve the current state, includes watercourses (or portions) on which any new structure that acts as an obstacle* to the ecological network may not be authorised or granted;
- list 2 is drawn up for watercourses (or portions) for which it is necessary to restore the conditions of the ecological network: any existing structure must therefore have implemented the necessary provisions (fish and sediment circulation) within 5 years after publication of the lists (this period may be extended, subject to certain conditions).

What are the solutions?

■ Installation of a corbelled * bench*

Concrete frames, concrete ducts as well as masonry bridges can generally be drilled (be careful, for concrete structures, to take precautions, for example with a metal detector, to avoid drilling the reinforcement) for the insertion of dowels (usually with chemical sealing) allowing the fixing of brackets or other fastening devices, of a decking system made of rot-proof materials (reinforced polyester made of fibreglass, recycled plastic, concrete). Wood has the advantage of being a natural material.

The corbelling* technique has several advantages:

- from a hydraulic point of view, the reduced section is often negligible and the risk of obstructions is limited by the use of brackets without braces;
- from the regulatory point of view, administrative formalities pursuant to the French Water Act are often limited to consultation/information of water police services (unless specific suggestions for access to the site or the positioning of a work base are made). However, the hydraulic capacity of the structure must be checked;
- from a financial point of view, the corbelled* bench* is more economical than a concrete bench.

Corbelled* bench* created by a bracket and decking

*Bench bracket**

a) For decking brackets, it is recommended to use galvanised steel to prevent corrosion. Stainless steel brackets are to be prohibited (high risk of theft). The shape of ducts must be adapted to the walls of the structure (radius of curvature). Depending on local practices or the risk of obstructions in the structure, they can be bracket-shaped with a brace (❶) or "T" (❷).

b) Brackets are usually placed every metre. These intervals are needed to avoid deformation of



❶ Square bracket. Source: Cerema.



❷ "T" bracket with radius of curvature. Source: Cerema.



❸ Bench with 40cm wide by 50m long concrete decking and 60cm headroom. Cost: 6,000 € (installation under local authority control). RN164 (DIRO). Source: Cerema.

the recommended material which should be fixed to the bracket. If the material used is different and very rigid, these intervals could be adapted without neglecting the number of times the decking is fastened to secure it over its length. For greater safety and to avoid the decking falling in the event of an anomaly in a bracket, a minimum of three fasteners per panel can be envisaged.

(c) Galvanised steel brackets will be fixed by chemical sealing.

Simple implementation solutions such as chemical vial systems (chemical resin sealing to be inserted in the bore) are recommended. They have the following advantages:

- high load bearing capacity;
- small drilling diameter in relation to the load taken;
- avoids moisture from entering into the support.

(d) For obvious reasons of safety, efficiency and manoeuvrability, the use of a battery-powered drill is recommended.

Bench decking*

The interior of waterway structures has special features, such as permanent ambient humidity and

fluctuating water levels that can flood the bench. It is therefore preferable to use rot-proof or low-rot materials.

Different materials can be used: concrete (see previous page), recycled plastic, glass reinforced polyester (GRP), wood, etc.

The use of recycled plastic decking is recommended (see recommendations on next page).

In order to reinforce the structure and avoid deformations between the slats, the latter can be fixed to one another.



Decking in recycled plastic

- Decking dimensions are as follows: 205cm x 105cm, 2.5cm thick for 51kg in weight. Without toxic treatment, non-slip, this material is processed like wood. It can be easily cut and portioned. Feedback on this material indicates excellent longevity.
- In most structures, this decking is cut into two to obtain a bench* a little longer than 50cm. For small structures (e.g. DN duct x 1,500mm), it is possible to cut 3 x 35cm wide slates from a plate. This is cut in the workshop to avoid the massive dissemination of plastic chips in nature.
- The plastic decking can be fastened onto galvanised steel brackets directly by screws or via a plastic slat (see illustrations below).
- To avoid their deformation, the decking slats are connected using a previously cut piece of decking or galvanised steel plates (see illustrations below).



Detail of fastening and connection of the decking.
Source: Cerema.



Detail of fastening and connection of the decking.
Source: Cerema.

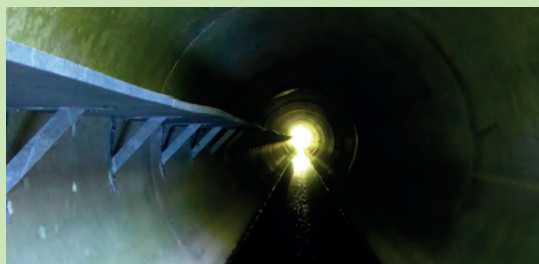

Recycled plastic bench, 50cm wide by 65m long and 70cm headroom. Cost: €15,000 including VAT (2013). RN137 (DIRO).
Source: Cerema.





Mixed wood/concrete decking in 120 x 20mm thick slats is easily breakable and not recommended. Source: GREGE.



Supply and installation of a corbelled bench* consisting of a support and decking in:

- concrete, fibre cement: €250 to 300 excluding VAT/lm;
- metal: €200 to 400 excluding VAT/lm;
- recycled plastic: €150 to 250 excluding VAT/lm;
- glass reinforced polyester: €300 to 600 excluding VAT/lm;
- wood: €100 to 150 excluding VAT/lm.

Prefabricated corbelled* bench* (on concrete or masonry structures)

There are prefabricated devices (glass reinforced polyester ④ ⑤, polymer concrete ⑥ and ⑦) which

are lighter than conventional concrete and very easy to handle. These cast systems also have the advantage of being in one piece and combine both the bench and the brackets. They can be covered in a non-slip coating.



④ ⑤ GRP bench, 50cm wide by 67m long and with 200cm headroom. Cost: €35,000 including VAT (2015). A83 motorway. Source: Cerema.



⑥ Genet using a polymer concrete bench. Source: Vinci Autoroutes/ASF network.



⑦ Polymer concrete bench with non-slip device. Source: ULMA Architectural Solutions.

■ **Construction of a concrete bench
(in a metal duct, a concrete
or masonry structure)**

A concrete bench can be installed which has the advantage of being durable. It makes it possible in particular to equip metal ducts which are very widespread on old networks and cannot be drilled as this might worsen the risk of corrosion.

However, these benches have several drawbacks such as higher cost, the need to carry out in-depth hydraulic studies, and greater obligations related to compliance with the Water Act (in the study phase as well as in the works phase, see below).

Studies are needed to check that the flow velocities are always compatible with the movement capacity of species living in the watercourse, as the narrowing of the bed leads to increased flows in the structure.

In addition, the work usually requires temporarily diverting the watercourse inside the passage, in order to be able to work in a dry environment.

This diversion can be done by installing a cofferdam (e.g. sandbags + geomembrane) or by temporarily diverting the stream inside the structure via a duct (⑧).

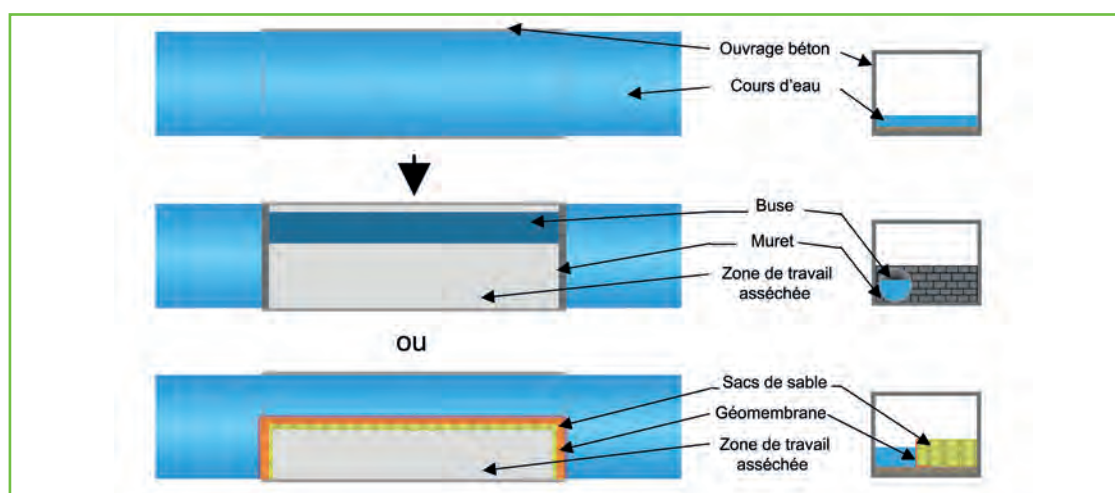

⑧ Principle of temporary deviation of a watercourse to conduct work inside a structure. Source: Cerema.

When the water depth of a structure fills the entire bottom, there is not always enough water during periods of low water to maintain the ecological network. By reducing the width of the bed in the structure, the construction of a concrete bench can make it possible to restore this fish continuity, by increasing the height of water in the structure.

The construction of an L-shaped concrete wall-type bench filled with topsoil is to be avoided, because in the event of flooding of the watercourse, the materials are completely leached and the bench empties.



The cost is around €1,000 to 2,000 excluding VAT/lm for benches 40cm to 50cm wide.



Concrete bench RN 165 (DIRO). Metal duct. Source: Cerema.

■ Bench* made of natural materials (masonry or not)

When the structures are wide enough, and hydraulic conditions allow it (low velocity), the benches can be made entirely of natural materials. They then have the advantage of preserving both a terrestrial movement corridor and the natural bed of the watercourse. When required by hydraulic conditions, the components of the latter may be sealed (9).



The cost of producing a bench* made of natural materials varies greatly depending on whether a simple input of soil or masonry blocks are involved:

- soil: around €150/lm;
- rockfill (masonry or other: €350 to 750/lm.



9 Development of a bench made of natural materials (sealed inside) in the crossing structure of the marten stream on RD12.

Source: Departmental Council of Dordogne.

■ Installation of a floating bench* (all types of structures)

This solution consists in installing a floating structure inside the structures (10+ insert next page). It offers the following advantages:

- easy and speedy implementation;
- fluctuation according to the water level allowing a constant shoreline connection;
- it can be fitted on small sectioned structures;
- easy to dismantle.

This system requires the bench* to be properly connected to the banks of the watercourse and therefore needs a system that is longer than the length of the structure.



10 Floating bench. Source: Pascal Fournier, GREGE.



Development of a floating bench* 50cm:
€150 to 250 excluding VAT/lm.



The Mink & Otter Pontoon &, a floating fauna passage for structures where corbelling* is complicated

Developed by GREGE since 2009, the Mink & Otter Pontoon allows the restoration of movement corridors inside waterway structures for the safe circulation of semi-aquatic mammals, while ensuring circulation as close to the water as possible, including up to the highest flood levels.

Due to its floatability, this device has a minimal hydraulic impact and is perfectly adapted to rivers with high hydraulic tides. Its anchorage system allows the installation of all types of structure, even those with no interior fixtures.

Its design provides simple and fast installation, even in very low structures, without requiring heavy machinery or installation of a work site. Its main advantage lies in a restoration of continuity in structures that are difficult to equip with other simple solutions.

Its installation consists of an assembly of light elements, a fastening system adapted to the ends of the structure allowing vertical movement, a thickness of 70mm easily accessible from the water and a connection to the bank to ensure continuity of the device at low water or flood levels, and even during high tide for those structures subject to it.

Tested *in situ* from 2009 to 2014, then deployed, to date, on 15 structures spread over the west of France, from Mayenne to the Landes, this system is regularly monitored, using footprint sensors or camera traps.

Current data demonstrates its functionality for semi-aquatic mammals (European otter, mink, Southern water vole, etc.) but also for other mammals (genet, marten, weasel, fox, etc.), even on linear sections measuring more than 50m and or in a 1,200mm duct.

The new generation is now available in polypropylene for improved durability, with a stainless connection guaranteeing linear strength.



Floating device. Source: GREGE.



Connection of the Pontoon to the bank. Source: GREGE.



European otter on the prototype pontoon. Source: GREGE.



Fox on a pontoon. Source: GREGE.



Weasel and stoat on the ink footprint sensor used to assess use of the Pontoon. Source: GREGE.

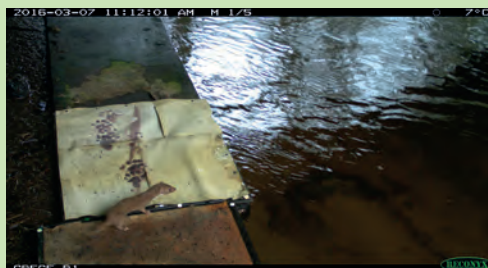

In order to prevent the removal of the floating bench* (①), this solution is not recommended on watercourses with high flows or in structures in which the watercourse can pass from a slow flow to a torrential flow (e.g., smooth concrete structure, slope and smaller section than the watercourse). It is also not recommended in watercourses known to carry many log jams.

Installation rules and dimensions

For optimum operation, the dimensions of the bench* must, as far as possible, comply with the construction rules for new structures. The initial objective will be:

- the wedging of a bench on the natural banks of the watercourse corresponding to a rating slightly higher than the two-year return flow Q2 (or Q3) for natural watercourses;
- headroom* 70cm above the bench;
- a 50cm wide bench seat;
- sufficient resistance to allow a person to pass through (inquisitive persons, maintenance, etc.).

However, in the context of the upgrading* of existing infrastructure, it is often necessary to deal with the characteristics of the structures in place. The type of bench, its width and the headroom* must be adapted to each structure configuration.

When the situation so requires, it is possible to depart from the rule and to give priority to the implementation of the development, even if the dimensions usually recommended are not respected. In this case, however, it will be necessary to validate this dispensation by an ecologist specialised in the subject (width can be reduced to 30cm for otters and mink and acceptable headroom close to 50cm).

The possibility of creating a bench and the choice of the type of devices are determined in particular by:

- **the hydraulic capacity of the structure**

The development of a bench must not have a significant impact on the upstream water line (increase in the flood line), especially if there



① Example of an experimental floating device installed in an 85m duct carried away by the current, following breakage of the anchorage on the duct head.

are issues (housing, roads, etc.). As such, the development of a corbelled bench* affects the size of the structure less than a full bench and therefore has less effect on upstream flow. A hydraulic study may sometimes be necessary to ensure this.

The hydraulic study also makes it possible to visualise the height of water in the structure according to the flows and to wedge the level of the bench by taking into account both the minimum reference headroom* and the potential level of immersion.

When no rating is known and in the absence of a specific study, the examination of floods on the structure gives good indications of the highest recurrent water levels. This height must also be consistent with the connection to the banks.

- **fish crossing capacity**

By reducing the hydraulic capacity of a structure, the development of a bench can be accompanied by an increase in the flow speed, particularly when the bench reduces the width of the bed (e.g. full benches). It is therefore necessary to check that this water velocity remains compatible with swimming capacity and therefore the ability of the fish species present to cross. It is commonly accepted at this level that about 80% of the time (generally corresponding to a range of flow rates between QMNA5 and 2 to 2.5 X Module) the species present must be able to pass through the structure (see *Information Note No. 96: Petits ouvrages hydrauliques et continuités écologiques. Cas de la faune piscicole*. SETRA, 2013).

Even if this regulation applies to corbelled* benches* or full benches, when there is an excessive speed increase, the choice of a corbelled bench is generally preferred, because there is less impact on flows.

Additional facilities in the bed of the watercourse (deflectors, bars, rockfill, etc.) may also accompany the development to limit speeds in the structure or create resting zones that allow fish to pass through the passage.

The narrowing of the bed by the inclusion of a bench can also improve fish's ability to cross the river at certain times. This is the case when the water level in the structure is too low for the fish to swim through the passage. In this case, the narrowing of the bed makes it possible to increase the height of water in the structure.

- **the presence of target species**

For sensitive species (otter, mink, beaver), the rating of the bench is, if possible, raised to that of the 10-year flow rate **Q10**, when it is known and when there is sufficient headroom* between the lower surface* of the structure and the bench (> 50cm).

However, compliance with this recommendation depends on the characteristics of the structure in place and the surroundings (it is sometimes impossible to position the bench above Q2). It is

necessary to adapt to the site, the objective being to promote the passage of the otter and beaver, in dry-standing areas, in the structure and in the surroundings, even though the hydraulic velocity of the structure is too fast for these species to be able to cross the infrastructure in the watercourse. Although they are very good swimmers, these species constantly seek to save energy and prefer to use a "dry-standing" crossing rather than a structure with a strong current within it which would take too much effort.

When the structure is wide enough, it is advisable to equip both banks. In the case of a smaller structure, the **choice of the installation bank of the bench**, as well as the **way it is connected to the bank** are essential for the proper functioning of the device (12). The installation on the right bank or on the left bank may depend on: the sinuosity of the watercourse, the degree of naturalness of the surroundings of the structure, human use, the installation of possible fences and suggestions for subsequent maintenance. **The connection to the bank must be continuous.**

These two elements must be decided in consultation with the manager and an experienced naturalist.

In some contexts, the installation of a wooden rail fixed on the bench can avoid the fall of species likely to drown into the watercourse (hedgehogs for example) (13).



12 Example of a connection to the bank.
Source: Cerema.



13 View of a wooden rail fixed to a corbelled bench.
PNR Marais Poitevin. Source: Cerema.

Continuity restoration in hydraulic discharge structures equipped with a water ditch

Some hydraulic discharge structures could become fauna passages. However these structures may have been designed with ditches which, when located at the bottom of valleys at the table water level, frequently fill up with water (14). Wildlife can then no longer cross them.

To restore the structure's permeability to terrestrial fauna, it is recommended to fill the water part (which does not contribute to the hydraulic

capacity of the structure because it is filled) (15). However, care must be taken to maintain a sufficient upstream-downstream slope to maintain the hydraulic capacity of the structure.

Also be careful that the ditch has not been colonised by species requiring specific consideration (e.g. protected amphibians). The installation of a side bench* can provide a solution to the discontinuity.

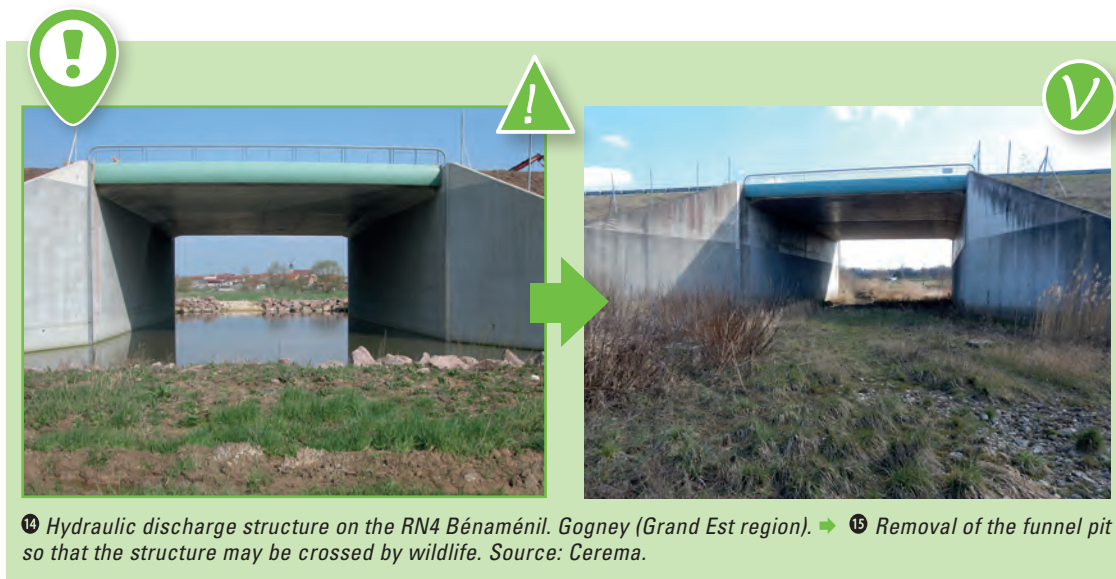

2.2 Construction of new structures on existing infrastructure



Roe deer, A7, GrandBoeuf structure. Source: © VINCI Autoroutes photograph library – Emmanuel Rondeau.

FACT SHEET

17

Where and how to build an all fauna passage on existing infrastructure?

In the case of the construction of a new passage for the upgrading* of an existing infrastructure, the design and layout requirements for the immediate surroundings are identical to those given in part one.

Costs vary according to the width of the structures, their characteristics and local contexts.

Apart from technical constraints, the main construction difficulties are related to:

- traffic on the existing road which requires traffic interruptions or more or less long alternating

traffic, depending on the constructional features of the structure;

- access to the site, which is sometimes from outside the infrastructure which the contracting authority does not usually own.

Beyond the technical constraints, this solution very often comes up against the economic constraints that make this type of construction difficult as well as local opposition that considers these investments are not a priority (see fact sheet no. 4, "Guaranteeing social acceptance").



Creation of the underpasses on the RD 121a and 1085 Departmental council of Isère

The ecological network between the Chartreuse and Vercors mountains is altered by various infrastructure. As part of its "couloirs de vie" or "corridor of life" project, the Departmental Council of Isère has carried out various actions to restore this continuity. Among those aimed at restoring the ecological corridor of the Cluse de Voreppe, the Departmental Council has built two underpasses in the municipalities of Voreppe and Saint-Jean-de-Moirans.



*Underpass on the RD121a.
Source: Departmental council of Isère.*



Creation of the specific overpass of La Buisse on a motorway with a slight embankment

The access embankments to the passage de La Buisse have been designed to:

- reduce road coverage, especially to avoid encroaching on a flood zone and to protect part of an existing hedgerow;
- create a transversal access ramp that starts at 25% and then becomes less steep as the structure is approached;
- create ramps with a moderate slope (maximum 15%) longitudinally (in continuity with the paths that usually run along fences).



*La Buisse passage on the A48 motorway.
Source: R. Courtaud - AREA.*



Specific overpass of the Col du Grand Bœuf on an excavated infrastructure. ASF/Vinci Autoroutes

Located on biogeographical crossroads linking the Alps and the Ardèche, the Col du Grand Bœuf is crossed by the A7 motorway. Since its construction in 1965, this motorway has been a physical barrier to wildlife movement. Following a landscape ecology study that showed the importance of this site as a regional crossroads with high issues for wildlife movement, it was proposed to build a fauna passage to restore the ecological network interrupted by the infrastructure.

In 2011, a 15m wide structure was built over the existing motorway.

The structure consisted of a metal frame placed on two concrete supports at each end. The 36m long frame was installed with a crane and required closing the road to traffic for one night only.



Sketch of the eco-friendly bridge* (photomontage) of the Col du Grand Bœuf on the A7 motorway. Source: Vinci Autoroutes/ASF network.



Passage under construction. Source: Vinci Autoroutes/ASF network.



Finalised passage. Source: Vinci Autoroutes/ASF network.



The indicated cost of the operation was approximately 2.6 million (in 2011).



The cost of construction varies greatly depending on the context, the types of structures, the foundations, etc. The data in our possession (mainly from motorway concessionary operators) shows a structure price ranging from €2,500 to 5,700/m². However, this price only covers the cost of construction. In the context of an upgrading programme*, it is also necessary to take into account many other items (upgrading to motorway standards, studies, procedure, site installation, etc.) which can significantly increase the total amount of an operation (up to several million euros).

FACT SHEET

18

How to create a small fauna passage on existing infrastructure?

By boring or microtunnelling

The upgrading* of a network and in particular the creation of a new fauna passage must, in most cases, adapt to the operational requirements and the obligation of continuity of service. It is therefore sometimes impossible to open the infrastructure by conventional methods of trench excavation to create a structure. Trenchless working techniques can then be used: boring (between 300 and 800mm) or microtunnelling (between 500 and 2,500mm).

These techniques consist in installing a duct (made of metal, concrete or GRP) with a diameter between 300 and 2,500mm in the infrastructure embankment and in extracting the cuttings as and when they are removed.

When a tube is positioned, the next one is put in place and inserted into the previous one. The operation continues until the drilling tool opens onto the other side of the embankment.

The execution of the works requires great precision so as not to jeopardise the operating infrastructure. The drilling tools are guided electronically by laser from the surface. The alignment corrections are established immediately and according to the progress of the drilling.

It is accepted that the boring or microtunneling on a road infrastructure in operation requires an embankment thickness above the future structure equivalent to twice the height of the structure (❶). Moreover, for a railway track, the thickness of cover to be kept under the sleepers is at least four times the diameter and never less than 3m.

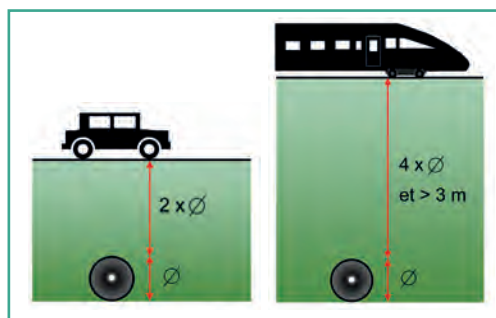

❶ Diagram showing the height of embankment to be maintained above the structure according to the type of infrastructure. Source: Cerema.

To maintain traffic safety and fluidity, access to the site is generally possible from outside the infrastructure coverage.

For work under a railway track, additional precautions must be taken (approved companies, temporary slowdown of traffic and permanent monitoring of the geometry of the railway tracks during works). The studies are systematically carried out by SNCF Réseau, because the safety of rail traffic is at stake.

Boring or microtunneling requires a fairly large work area (500m² minimum for boring, at least 1,000m² for microtunneling) to allow the storage of ducts, the generator, thrust device, mud and spoil separator and site facilities.

All precautions must be taken during the construction phase to avoid impacts on the surrounding natural environment. Work platforms, access tracks (see photograph on next page), storage areas are generally covered with a geotextile itself covered with materials, in order to facilitate clearing and restoration of the site.



*Site access track.
Source: ASF/Vinci Autoroutes network.*

To limit intrusions by small fauna, such as amphibians, the work area is fenced (1m buried fence) with a fine mesh, a tarpaulin or a fence with larger mesh on which the geotextile is positioned (the advantage in the latter case is that the fence does not need to be buried).



*Small fauna passage at Velaux A7 motorway:
View of the boring machinery.
Source: Vinci Autoroutes/ASF network.*

The duration of the boring or microtunneling is variable (several weeks), it includes creating access paths, departure and arrival pits, doing the actual boring or microtunnelling, related works (fence, duct heads), as well as the restoration of the site.



Feedback indicates costs of carrying out a boring operation under a motorway of approximately €9,000 to 10,000 excluding VAT/lm.



*Small fauna passage at Velaux A7 motorway:
view of the finalised device on the boring platform side.
Source: Vinci Autoroutes/ASF network.*



Setting up of microtunneling on a railway track. Source: Christian Chéreau - SNCF Réseau.



By opening the lane

Although a small fauna structure can be built according to different construction methods, the most logical technique, in principle, consists, in the absence of constraints, in digging a trench in the existing infrastructure in order to install a box culvert* or a concrete duct.

This technique is the only one that can be used when the height of the road embankment is insufficient and prevents any boring.

However, care must be taken with:

- operating constraints: the trench is opened on each half-road. This constructional mode is therefore to be reserved for infrastructures with little circulation, which does not incur prohibitive costs related to the protection of works while traffic is operating;
- the presence of buried networks.

Some rules of implementation must also be respected:

- altimetric positioning at the highest point (to avoid excessive flooding of the passage);
- the interior and exterior height of the structure: if possible 1m, without being less than 50cm;
- **the installation of a physical barrier next to the structure (fence) to encourage species to use the structure;**
- sloping bank* to access the passage (maintenance facility).

The structures must be laid on a bed of sand. The cover backfill must have a sufficient thickness that is related to the type and category of infrastructure (e.g. at least 0.8 times the diameter of the duct but not less than 1m for railways). The various thicknesses (sand bed and cover backfill) and the characteristics of the materials are determined during studies by the contracting authority.



Installation of dry ducts dedicated to otters.
 Source: François Varenne.

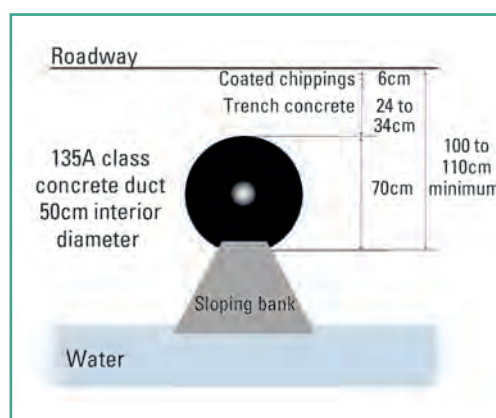

Principle for installing a duct under a roadway.
 Source: PNR du Marais Poitevin. François Varenne - LPO 85.



The cost of installing a small fauna structure by opening the roadway ranges from €750 to 1150 excluding VAT/lm for concrete tunnels to €150 to 250 VAT/lm for PVC structures. However it should be recalled that these developments must be reserved for low traffic infrastructure, especially for traffic management reasons.



Installation of dry ducts dedicated to otters PNR Marais Poitevin

In the Marais poitevin, "dry duct passages" (16 developments) have been built next to several road mortality points for otters. These mortality points, which correspond to intersection points between the road and the hydrographic network or wetlands, can be linked:

- either to the absence of structures under the road;
- or to the presence of a passage that does not have a terrestrial bench* accessible to wildlife during the high flow period (high current velocity in the structures). This situation encourages the otters to pass onto the road rather than use the structure.

Some of these points of conflict were managed by opening the roadway and installing class 135A reinforced concrete ducts with an internal diameter of 500mm (on lanes not exceeding 15 linear m). This category of structure was chosen because it is strong enough to accept a low backfill height while meeting road standards.

The minimum height required between the lower generator and the top of the roadway is 100 to 110cm. The cost of the improvements made varies between €11,000 and 17,800 including VAT for crossings covering a dozen or so linear metres.

In most cases, each end of the passage is equipped with a fence (5 x 5cm mesh, 1.2m to 1.5m in height) or a wooden railing whose purpose is to channel the animal towards the entrance of the structure. With some exceptions, the installation of this device impacts a maximum of a few metres (5 to 10m) on either side of the passage route. This length is sufficient to guide otters to ensure regular use.



*Opening of the roadway for laying the elements of the structure.
Source: François Varenne.*

*Finalised structure with fence device to prevent the otters from returning to the roadway.
Source: François Varenne.*



Construction of a small fauna passage in the motorway embankments of the A89 linking Clermont-Ferrand to Brive-la-Gaillarde within the Biodiversity Programme* of the Motorway Recovery Plan. Département of Corrèze (19). Cognac TP/Eurovia

Unlike most of the new small fauna passages created under the program, this work was carried out by opening the roadway, due to the lack of cover on the structure and various geotechnical problems.

The work lasted 4 months and required 2 months of preparation. It was performed on each half-road with alternating traffic.

The structure, around 40m long, consists of prefabricated frame elements 1,200 x 1,200. In addition to the installation of the elements, the work required: the opening of the roadway itself, the reinforcement of the trench, surface repair, the installation of prefabricated structure heads, the construction of concrete ramps, plantations, the installation of fences over nearly 600 linear metres and the rehabilitation of the site to good working order.



Opening of the roadway and reinforcement of the trench.



Implementation of elements of the structure.
Source: TEC INFRA/Engineering office
VRD & Project management



Surface repair. Source: Cerema.



Finalised work before the fencing was installed.

By installing a canopy passage

In certain specific cases where high-issue climbing species are identified (particularly overseas, but this may also concern the red squirrel and gliridae* such as the shrew in mainland France), the canopy corridor may prove to be an interesting solution.

Part one (chapter 3, "Development of dedicated small fauna passages") proposes the installation of gantries fixed above the road for new works.

In upgrading*, the technique usually used is the installation of a tightened rope, the braiding of ropes or a metal cord between two weight-bearing trees. These trees have to be sufficiently large and stable to ensure the solidity and durability of the structure. In the case of small-diameter trees which cannot guarantee the good strength of the system, an alternative solution consists in installing, on either side of the roadway and halfway between the latter and the edge, 6 to 7m wooden or metal posts between which a rope, a rope ladder or a metal cord is stretched. Recent publications (Goosem et al. 2005, VicRoads 2012, Yokochi & Bencini 2015) indicate that the posts must comply with this minimum height of 6 to 7m so as not to hinder road traffic and to make the lowest layers of the canopy reachable.

The foundation of the posts must be adapted to ensure their stability, taking into account the

possible presence of water likely to damage the foot of the posts, the most sensitive part. If necessary, the posts may be stayed with cables to anchor them to the ground at the edge of the wooded areas.

A network of ropes or cords must connect the canopy to the posts ②. This allows:

- several anchoring points for the rope or cords for better solidity of the system;
- drainage of a more extensive part of the forest corridor (funnel effect).

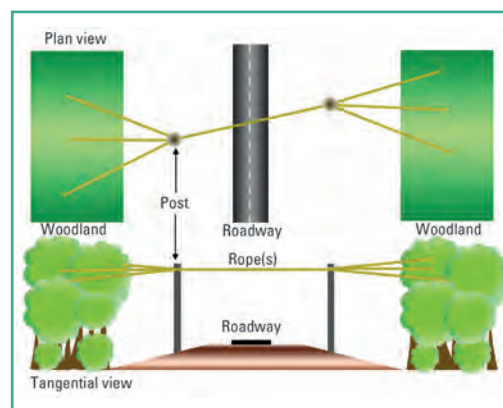

② Schematic diagram of a corridor for each canopy. Source: Cerema.



On two-way roads, systems using ropes cost around €2,000 to 3,000 excluding VAT.

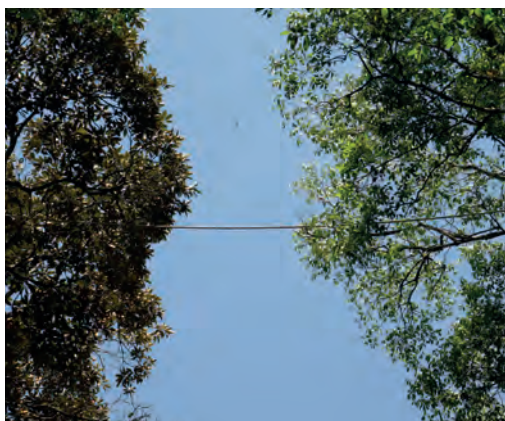

Corridor equipped with a rope bridge to restore the canopy link (RN2 - French Guiana). Source: Cerema.



Corridor equipped with a rope bridge to restore the canopy link. Source: Julien Soret - Métropole du Grand Nancy.

Other developments 2.3

Other types of development, sometimes in addition to dark or terraced structures, are set up to satisfy road safety requirements or according to the movement characteristics of the different species which constitute the issues of the developed areas. Several types of devices can be installed to limit the risk of accidents, prevent wildlife access to infrastructure or act as collecting structures to guide the animals to a dedicated, properly sized passage. It should be noted that these

anti-collision devices are for some high-issue species (such as European mink or otter) or, in some crossings, the first basis for upgrading*, by securing the movements of individuals. Among these devices, specific mention may be made of: warning devices, cattle grids, motorcycle barriers or fences.

Regarding chiroptera*, refer to the methodological guide *Chiroptères et infrastructures de transports* - Cerema. 2016.



Example of a crossing aid for bats

Bats are flying mammals, some of whose species follow landscape structures to guide their movements. All the structures used by the species form what are called "flight routes". When the infrastructure interrupts a flight route, the removal of landscape continuity can then constitute a real physical barrier for certain species and thus cause a decrease in their activity. However, some less sensitive species continue to cross the infrastructure despite the interruption. In this case, the main risk is that some individuals will fly down to the height of vehicle traffic and wildlife vehicle collisions will happen.

To reduce these risks, mitigation measures may be considered. One is to re-establish a crossing structure to guide the bats when crossing the infrastructure. It may be a usual fauna structure that can also be used by terrestrial fauna, but there are also structures dedicated to chiroptera*. These are generally gantry-type devices that are inaccessible to terrestrial wildlife and have no other objective than to provide a support structure high enough above the infrastructure for the bats to continue their movement while maintaining a sufficient flying height to avoid wildlife vehicle collisions.

Monitoring by Naturalia before and after the installation of a gantry installed on the A83 motorway (Vinci Autoroutes/ASF network) thus showed that the structure had made it possible to significantly increase the number of bat crossings over the motorway (Claireau et al. 2019).



*Installation of the gantry.
Source: Vinci Autoroutes/ASF network.*

What are the warning systems (fauna and/or vehicles) set up to reduce wildlife vehicle collisions?

To reduce the risk of accidents between wildlife and vehicles, there are many warning devices designed to alert, depending on the situation,

- fauna: to deter it from crossing or alerting of the potential or approaching hazard;
- motorists: to trigger their vigilance and encourage them to adapt their speed.

The efficacy of these devices is highly variable but, for the most part, often limited.

Reflecting surfaces

These systems, most often fixed to posts on the edge of the infrastructure, are designed to reflect light from passing vehicle headlights and convert it into a "light barrier", which is supposed to scare off animals. These devices have been available in many types and shapes for decades and their common operating principle is to reflect the headlights of approaching cars on the adjacent curb to prevent nearby animals from entering or crossing the road. Today, most reflectors are designed to change the colour of the light or to flash or flicker.

Although the results of numerous efficacy studies show very variable results, it seems that no long-term studies have shown a lasting reduction in wildlife vehicle collisions related to such devices. It seems that the main reason is that the animals get used to these recurrent visual stimuli. The positive effects sometimes observed in the short term may be related to the increased vigilance of the driver of the vehicle, stimulated by the reflector, which would

becoming accustomed to stimuli is often one of the main reasons for this. Some complex devices also require regular maintenance which, when neglected, leads to a loss of efficacy. Care must therefore be taken to retain and develop devices that require as little maintenance as possible.

These devices can take several forms (visual and/or sound).

temporarily limit accidents, or even to other factors which have not been taken into account such as population fluctuations, traffic reduction, displacement of wildlife vehicle collision points on other sections.



❶ "Piquet reflect".

Source: *Instinctivement Nature, FDC Savoie.*



A stake costs about €15 including VAT.

Acoustic devices

Like reflective surfaces, there are also acoustic systems attached to poles that make a whistling noise when stimulated by the light of approaching vehicles. Whistling is supposed to prevent wildlife from crossing the infrastructure, but the results of the various studies conducted on these devices are sometimes contradictory. It is therefore still difficult to decide on the merits of such systems.



Acoustic device attached to posts and triggered by the light of an approaching vehicle.

Source: Stefan Suter Wildlife Solutions WLS.CH.

New acoustic warning systems using recordings of natural sounds chosen according to the target species appear more promising. Combined with a detection device, these natural sounds deter the target species and are thus emitted to warn wildlife in advance of a danger, when a vehicle is approaching.

The long-term effectiveness of these devices has yet to be demonstrated, but initial experiments seem encouraging.

Other devices using the road surface (type of tarmac, grooving of the road surface) to emit sounds in the sensitivity ranges of the target species are currently being tested. However, more detailed studies are needed to verify the long-term efficacy of these devices.



Efficacy of an acoustic warning device for wildlife using natural sounds to reduce the risk of wildlife vehicle collision of animals with trains

J. Babinska-Werka et al., 2015

Tested in Poland on high-speed rail lines, the UOZ-1 animal deterrent is a system using a sequence of natural sounds representative of an imminent danger to the target species. These acoustic signals emanate from approaching trains and cause animals to flee.

The device consists of posts installed ² every 70m, alternately on each side of the tracks, on the accident-prone sections.

Tests carried out on the operating efficacy of the UOZ-1 show that these devices considerably reduce the risk of collisions between animals and trains by scaring them better and faster than the mere sound of the train. 85 to 93% of wild mammals (depending on the species) fled when trains approached and warning signals were emitted. Furthermore, there was no difference in results between the two years of studies (2008 and 2012), which suggests that the animals do not seem to become accustomed to the device.



² UOZ-1 post installed along a railway track.

Source: www.neel.com.pl

Driver information systems

Motorists are not necessarily aware of the risks of running over fauna and the installation of road signs can be helpful or even necessary to remind them (📍 next page). In some cases, these can be combined with speed limitation measures. Road signs can take several forms (danger warning sign, temporary or permanent road signs).

Studies indicate that the use of simple warning signs does not reduce vehicle speeds or the number of wildlife accidents. Road users, especially those who frequently use the route, seem to get quickly used to the presence of the sign. The combination of a panel with a speed limit is slightly more efficient. Efficacy is further improved if the panels are equipped with flashing lights when approaching the vehicle.

For amphibians, it is thus often preferable to set up temporary signs during migrations* so as to reduce habituation likely to reduce the efficacy of the panel.



📍 Information sign Source: ASPAS.

There are more sophisticated devices combining a system for detecting animals present at the edge of the infrastructure (infrared, heat detection, etc.) connected to a system for alerting drivers of this presence (flashing panels). When the signs light up, drivers are thus informed of the potential danger associated with the presence

of an animal in the vicinity of the road. These systems have proven to be effective, but they are reserved for relatively short sections and require regular maintenance to ensure their effectiveness.

New lighter warning systems are also being developed. While ensuring similar efficiency to the previous types of equipment, the purpose of these new devices is to limit the costs of purchase, installation and maintenance, in particular by miniaturisation of the devices.



Fauna warning device Animot. GmbH & Co. KG.

Installed on roadside beacons, this experimental device includes a passive infrared sensor powered by a battery recharged by a small integrated solar module. As soon as an animal is detected close to the road by the sensor, a light flashes and informs the drivers of the hazard related to the presence of the animal. Each device then communicates with its nearest neighbour, which also starts flashing.

Studies have already shown on equipped sections that when the devices are in action, drivers reduce their speed and more braking reflects increased vigilance by drivers.

While the long-term effects are not yet known, these systems have the potential to be of real benefit in terms of efficiency and cost.



Animot alert device.
Source: Martin Weber/PIRSCH.



Couloirs de vie (corridors of life) project Departmental council of Isère, 2008

Since 2008, as part of its European project to preserve biodiversity* "*Couloirs de vie*" ("Corridors of life"), the Departmental Council of Isère has tested, for the first time in France, wildlife detectors at 7 sites in the biological corridors of the Grésivaudan valley and the Cluse de Voreppe.

This heat detection system (installed by Neavia Technologies) makes it possible to detect an animal located close to the road, from the size of a hare, on a perimeter 300m wide (150m on either side of the device) and 30m deep. It consists of detection masts each equipped with 3 sensors and 2 flashing traffic signs, warning drivers as soon as an animal is detected. This device is sometimes coupled with a speed limit (4).

To avoid false alarms, the system does not take into account road areas or grazed fields and only lights up during the main periods of wildlife movement, namely one hour before sunset, up to one hour after sunrise.

The raw data was analysed over the period running from March 2013 to March 2014. It shows that, over this period of time, at least 3,750 animals were detected with more than 2,800 actual crossings. There are 10 to 15 alarms per night and per site with 5 to 10 actual crossings.

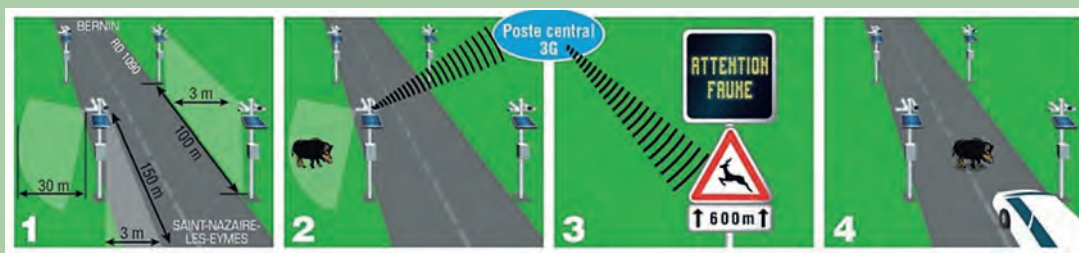

4 Schematic view of the wildlife detector. Source: Departmental council of Isère.



The cost is approximately €70,000 for a site equipped with 4 masts covering a section of 300m on each side (2 masts per traffic direction with an interval of 150m).

Mixed driver information systems and wildlife warning systems

Projects combining a wildlife detection and warning system aimed at fauna and the vehicle have also been tested.

Such devices have the advantage of acting simultaneously on wildlife and on drivers. They make it possible to dissuade the animal

from crossing the road only when there is a real risk of collision with a vehicle, so as not to interfere with its movements within the territory and avoid dependency on a deterrent system. The same applies for the driver, since the lighting system only works when the animals are in the vicinity of the road.



Life Strade Project in Italy

This is an innovative project to develop a system to prevent road mortality due to wildlife in central Italy.

The system operates as follows (1): a Doppler radar sensor (1) records the passage of an animal and transmits the information to an electronic control unit (2). This activates a light warning signal (3) urging drivers to slow down. A radar (4) records whether the car in question is driving at the right speed. If the car slows down, the system stops. Otherwise, the radar transmits a signal to the control unit (2), which activates an optical and/or sound deterrent system (5) to scare the animal away.

The sound deterrent system consists of a digital control unit that can contain more than 500 different types of sounds. It can diffuse diverse and unequal sounds. It also incorporates audio volume variation to eliminate the problem of animal habituation.



1 Illustration and photos of the alarm/scare system. Source: : <http://www.lifestrade.it> <http://www.lifestrade.it>



The total indicated cost of the installation of the project was estimated at approximately €13,000 for a device covering around 200m of infrastructure (NB, it was a test at this stage). This included the cost of 12 sensors for animal detection as well as technical assistance throughout the project (maintenance and replacement of damaged components and replacement in the event of theft).

Embedded systems

The mitigation of wildlife vehicle collisions will probably also be improved in the coming years thanks to the development of systems combining an on-board wildlife day and night detection device with an automatic braking device when an animal is on the road.

Many manufacturers have already installed such devices and seem to be making rapid progress, thanks in particular to artificial intelligence.



Systems embedded in vehicles to detect people and animals crossing the road are increasingly developed. Source: Volvo Cars.



On existing infrastructure - upgrading

Objective: upgrade old design infrastructure with regard to their wildlife permeability

Improving the functionality of existing fauna passages

Improving how existing fauna passages work by strengthening the system guiding animals to the structure (plantations), by qualitatively managing the vegetation already present, by improving the functionality of existing structures (e.g. removal of light wells).

➔ In contexts requiring it (high issues), the extension of overpasses is a conceivable solution.

Development of structures not dedicated to fauna passage

- A. In certain conditions linked to road user and fauna safety, creation of grassy benches*.
- B. Modification of the purpose of the structure not dedicated to fauna passage (agricultural and forest tracks in particular).
- C. Creation, in waterway structures, of a fixed bench* corbelled or not, or of a floating bench, dedicated to small fauna.

Construction of a new structure

- A. For large fauna (see previous chapter) keep an eye on the acceptability of such a measure in view of the costs involved.
- B. For small fauna:
 - ➔ by boring a tube into the road embankment;
 - ➔ by opening the roadway (installation of a tube or box culvert*);
 - ➔ by the installation of a canopy passage for tree species.

Reduction of the risk of wildlife vehicle collisions by proposing alternatives to structures: sound or visual alarms for wildlife as well as for road users

Recommendations

Wildlife can adapt to many situations, so the general idea is to promote all solutions that help improve the ecological network, even if they do not scrupulously respect the recommendations of dimensions or locations necessary for optimal operation.





GREEN RIGHTS-OF-WAY: SUPPORTING LONGITUDINAL CONTINUITIES

FACT SHEETS

- 20 How to integrate biodiversity into the design of rights-of-way?
- 21 How to ensure fauna's access to rights-of-way while ensuring its protection?
Fences and barriers

What are green rights-of-way?

Green rights-of-way are all the vegetated spaces adjacent to the infrastructure, such as verges, ditches, slopes, central reservations, rest areas and stopping points. They are subdivided into two categories: those that are directly involved in the operation of the structure (verges, ditches, etc.) and those that accompany the structure (slopes, fallow land, etc.).

Green rights-of-way located along infrastructure can, under certain conditions, accommodate a variety of habitats. At the regional level, the accumulation of these areas represents several hundred thousand hectares constituting a potentially

important network. Thus, the 9,048km of motorways under private management represent approximately 80,000ha of road coverage, of which 38,600ha are green rights-of-way and 29,273km of railway lines operated represent 110,000ha of green rights-of-way.

In addition, there are national and secondary road networks, which, although generally made up of smaller road coverages, have a much longer linear footprint and form a dense network throughout the country, with more than one million kilometres. Across France, the surface area of green rights-of-way of road infrastructure is estimated at between 4,500 and 6,000km² (source: Cerema Ouest).

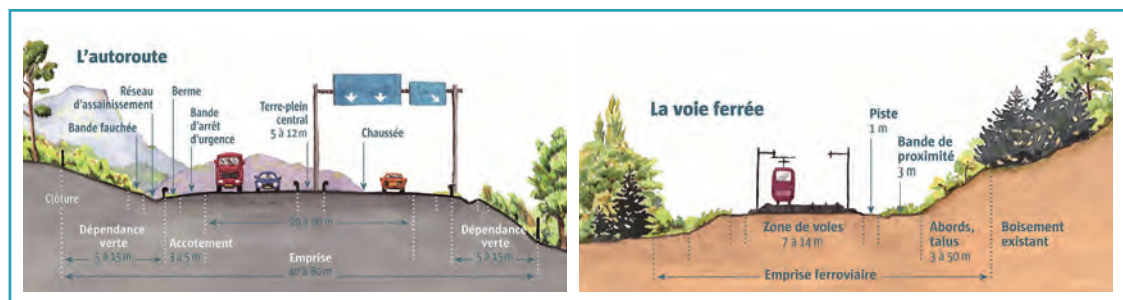

Cross-section of a motorway and a railway track.

Source: UICN France and CILB – Corridors d'infrastructures, corridors écologiques ? - État des lieux et recommandations.

What are the benefits of rights-of-way for biodiversity*?

Due to their shape, their narrow width, pollution and regular maintenance (mowing, gyro-grinding*, treatments, the use of machinery, the digging of ditches, etc.), rights-of-way do not seem, on the face of it, conducive to the development of species. This is particularly the case on the secondary road network. They are also often composed of slopes made of reworked land undergoing different types of work, making them favourable to the reception and dispersion of invasive species. Finally, in terms of continuity, they are frequently interrupted by transversal roads.

However, nature can be reconstituted and adapted after the works phases. Interesting environments

can develop and be maintained sustainably and many fauna and flora species can settle there and use these rights-of-way as movement corridors (IUCN France & CILB). This is particularly true on the motorway network as long as extensive management is set up to reclaim unspoiled areas. Moreover, it is in the most contrasting landscape situations that the role of infrastructure as a longitudinal continuity is most obvious: the crossing of intensive crops where road coverages contain the only meadows of the areas crossed.

The value of these areas for biodiversity also depends on other factors such as their management, their age, etc. It is therefore difficult to make generalisations about the value of green rights-of-way for biodiversity. The conclusions of scientific studies dealing with the potential of green rights-of-way of infrastructure like habitat or corridor remain ambivalent.



A systematic review carried out within the framework of the ITTECOP program by a team from the joint unit of the Patrinat department (bringing together the Office français de la biodiversité - OFB, the Muséum national d'histoire naturelle and the CNRS) together with Inrae and Cerema have made it possible to draw several conclusions concerning the specific question of the role of habitat or corridor played by rights-of-way of linear transport infrastructure for insects and vertebrates in particular, from an operational point of view. It appears that:

- for all LTIs, there is no significant net effect of rights-of-way on insect abundance and wealth compared with similar adjacent environments. However, there is a trend showing that road rights-of-way are more favourable habitats for pollinating and herbivorous insects than similar non-dependent habitats. This could be linked to "greener" management of these rights-of-way: reduction of chemical treatments, later mowing, maintenance of more natural environments, etc. However these interpretations need to be confirmed;
- for vertebrates, the edges of motorways appear to be a suitable habitat for micro-mammals* (mice, field mice, etc.), particularly in areas of intensive agriculture, but seem to be unfavourable for passerines (abundance and number of weaker species). This suggests that collisions with vehicles, which may be more frequent for birds, play a role;
- regarding management arrangements, even if some are not studied in depth and their effects poorly assessed, it seems that insects are less affected by them, whereas for vertebrates, reducing vegetation on the right-of-way tends to reduce the abundance of micro-mammals* on roadsides.

Reference:

Sordello, R., Villemey, A., Ouédraogo D.-Y., Jeusset, A., Vargac, Azambourg V., Witté I., Hulard M., Reyjol Y., Touroult, J., *Connectivité longitudinale et potentiel d'habitat des dépendances vertes en fonction de leur nature, des espèces et du contexte : une revue systématique sur les infrastructures de transport.*

Cohnecs-It Phases 1 et 2.

Against a backdrop of intensive agriculture, rights-of-way are significant areas of refuge for many species and can host rare species for which they play a role in terms of conservation and dissemination.



Intérêts écologiques pour la flore des bords de route en milieu agricole intensif L. De Redon, MNHN, 2008

This study carried out in 2008 in an intensive agriculture landscape showed that roadsides were home to 65% of plant species sampled in the different environments represented (fields, woods, roadsides) and that 50% of them were found exclusively within these green rights-of-way.

Green rights-of-way, although they do not always constitute habitats for species, play a corridor role by connecting different patches of habitats present within the agricultural matrix. They also supplement local continuities by effectively guiding animals to existing fauna passages and contribute to infrastructure transparency (e.g., ❶ next page). This aspect is particularly important in highly urbanised, open or agricultural landscapes, where there are few opportunities for habitats conducive to movement. However, these same rights-of-way remain richer when the landscape context is natural, compared to a context of intensive or urban agriculture.

The value of green rights-of-way for the reception of species depends however on their width, maintenance mode (mowing/shredding, date, mowing height, etc.) or the types of environments present (hedges, meadows, etc.).



❶ Example of the role of connecting rights-of-way between corridors and fauna passages. Source: according to Vinci Autoroutes.

While green rights-of-way may have an ecological benefit for wildlife and its movements, attracting animals to the edge of infrastructure can also increase the risk of wildlife vehicle collisions. They can then sometimes become lethal traps, or even create a real sink effect. This attractiveness is most often linked to the development and maintenance

of these rights-of-way which determine their value as a habitat or corridor. It is therefore necessary to make compromises between the various issues inherent in the operation of a linear transport infrastructure (❷), given that technical and safety issues remain a priority in relation to ecological issues, in particular in the close vicinity of roads.

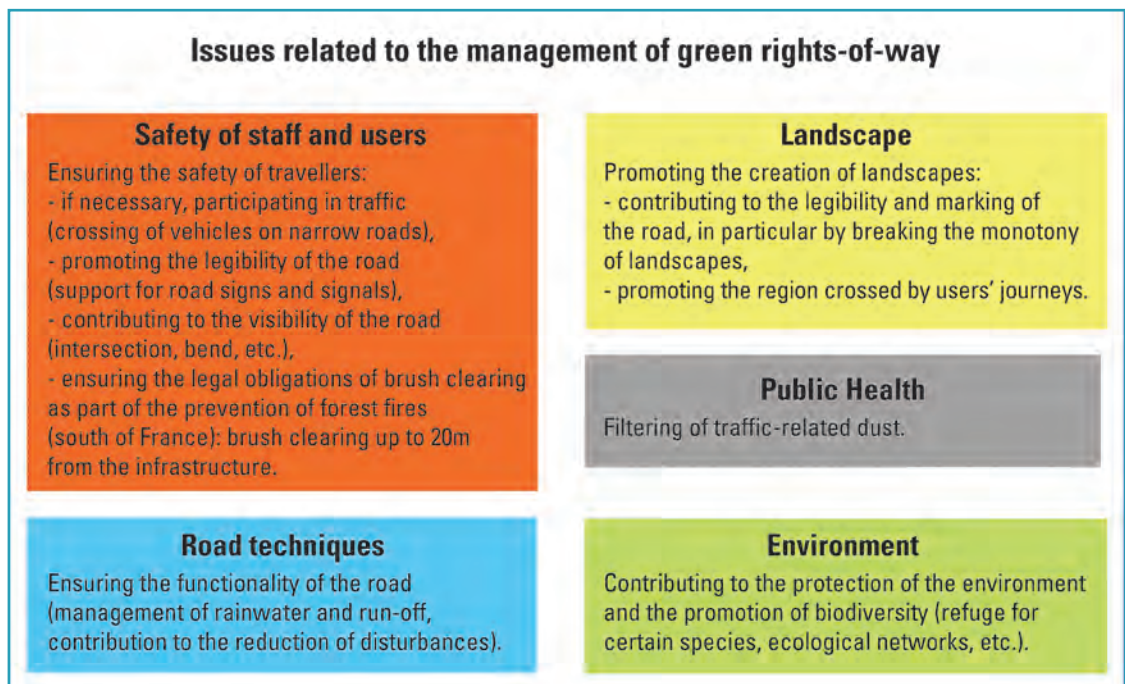

❷ Different issues related to the management of green rights-of-way. Source: Cerema.

How to integrate biodiversity into the design of rights-of-way?

At the design stage and during network upgrading* interventions, it is important to ask questions about the development of rights-of-way, how they can

fit into local continuities, and the management of these rights-of-way in order to make them "easy", sustainable and favourable to biodiversity.

Modelling of roadsides favourable to biodiversity*

Rights-of-way are most often modelled for technical operating or construction purposes (maintenance of slopes, balance of earth-moving materials on all or part of the route, etc.) or for landscaping.

In certain situations and particularly in the vicinity of the widest infrastructure such as motorways or dual carriageways, the integration of issues related to natural environments, in particular those related to the ecological network, can also be considered. The development of rights-of-way allows a certain latitude in modelling, especially in terms of microtopography, to diversify the environments and reception capacities for wildlife. However, these interventions are still infrequent. It is also necessary to take into account earthwork issues and cut and fill balances so as not to multiply slopes that are difficult to handle for infrastructure managers.

Most of the time, the "ecological" modelling of rights-of-way has protection objectives. This is particularly the case for birds. When road coverage is wide enough, and particularly when there extra materials are available, it is conceivable to install an earth mound planted with shrubs - for example an anti-noise mound - on the collision hotspot. This context reproduces that of an excavated linear transport infrastructure, which has a significantly lower probability of collisions between birds and traffic. This mound must be almost as high as a truck, so that the birds are forced to fly over the vehicles (about 4m). In addition, the acoustic mound provides the advantage of creating a quiet zone for species most sensitive to noise (bearing in mind, however, the problems of maintenance) which choose to settle down or move along the infrastructure (1 and 2 next page).



1 Development plan of protective mounds ensuring the protection of flying wildlife and the tranquillity of rights-of-way for terrestrial fauna. Source: Cerema.



② Development plan of mounds in an excavated zone ensuring the tranquillity of rights-of-way for terrestrial fauna. Source: Cerema.

In order to facilitate the movements of the animals and to channel their passage at the level of the rights-of-way, the installation of a flat surface, parallel to the road, in the form of a berm* can be envisaged in the slopes (③). This is particularly recommended when the slopes are steep. Another

advantage of berms is that they help stabilise large slopes and the installation of fencing.

In any case, this modelling is to be correlated with the planting strategy set up in order to be fully effective.



③ Development plan for berms* in large excavation zones to create a zone conducive to the movements of wildlife and to install fencing. Source: Cerema.



Gabion* wall development RD 16 (CD57)

In some situations, it is preferable, for technical reasons or to limit road coverage to replace embankments with retaining walls. Gabion* walls can then be used. They will provide favourable environments for reptiles, and even insects and amphibians. At the top of the device, it will simply be necessary to ensure that the road is well protected from any intrusion by this small fauna (e.g. concrete edge).

They also have the advantage of requiring little maintenance.



Gabion wall along the RD16 (57). Source: Cerema.

Favourable vegetation development

While seedlings and plantations often have a technical objective (control of the erosion of reworked land) or landscape-related goal (repair and integration of infrastructure), they can also contribute to the restoration of functional environments for flora and fauna and thus play a role in the ecology of the landscape (refuge area, movement corridor in particular).

For better insertion and recovery, like the development of fauna passages, the species chosen for seedlings and plantations must be indigenous and grow naturally on the type of soil crossed by the infrastructure (e.g.: "Végétal local" and "Vraies messicoles", see insert in fact sheet no 8). Good preparation of the plants, natural mulching (plastic mulching is prohibited) and adapted tillage at the same time as good climatic conditions of planting guarantee effective rooting. They do not need irrigation, but minimal watering is sometimes necessary during the guarantee period, when the conditions are severe (reworked soil, poor quality, slopes, etc.). The sowing of species adapted to local climatic and edaphic* conditions

(grasses, dicotyledons*, or even shrubs) is also a technique to be preferred, especially in the current section. Where appropriate and without leaving the soil bare, the natural regeneration of shrubby vegetation may be considered (be careful, however, not to favour the installation of invasive alien plants to the detriment of local species). This approach limits development costs (fewer plantations, fewer landscape interventions). Where possible, existing vegetation should be preserved as much as possible.

Landscape biases can be very diverse and must also take into account the landscape perceived from outside the infrastructure, but also the landscape for users of the infrastructure. It is thus difficult to define a standard layout that can be generalised to all rights-of-way. Depending on local issues, however, it is interesting to play on the structure of the vegetation to facilitate connectivity between the different habitats or fauna passages by setting up (double) hedges, alternating open and closed zones, bare zones, etc.



Planting a double hedge consisting of a continuous hedge as close as possible to the infrastructure (e.g. on top of the slope) and a broken hedge at the coverage boundary (e.g. at the bottom of the slope) offers several advantages such as:

- strengthening connectivity along rights-of-way;
- increasing habitat possibilities;
- delimiting the coverage of the infrastructure with a broken hedge, a role often played by fencing;
- and therefore positioning fencing as close as possible to the continuous hedge.

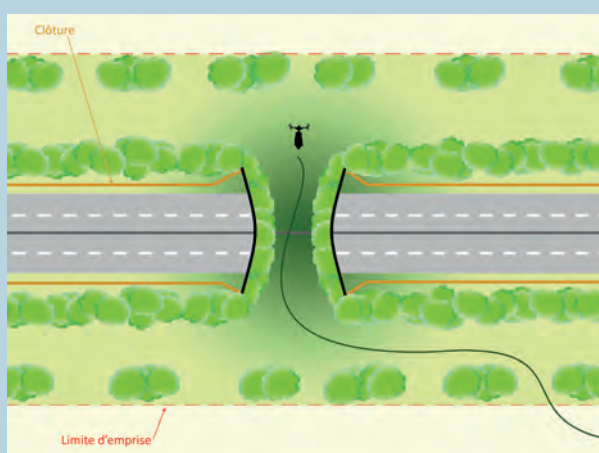

Schematic diagram of a double hedge.
 Source: Cerema.

As close as possible to the road (on the first few metres), however, the attractiveness of green rights-of-way must be controlled by avoiding the planting of edible species or nectar sources which can indirectly lead to more wildlife vehicle collisions. The planting of shrub cover on the rights-of-way or their maintenance as grass cover is recommended, in order to reduce the probability of birds colliding with traffic. For passerines and nocturnal birds of prey, the presence of trees at the edge of infrastructure can favour collisions with traffic (Guinard E., 2013). These results are, however, trends that require confirmation by more extensive studies.

Planting must also take into account the conditions of maintenance of fencing and

ditches by managers (angle mower, brush cutter, etc.). Generally, in the long term, 1.5 to 3m-long fence clearance is to be left at the edge of fencing and ditches.

In all cases, it is necessary to have a conversation with the operator well in advance of the design of the landscaping plan, to ensure sustainability.

For railways, the planting of trees must also be designed so that the leaves do not fall onto the rails. Indeed, decomposing leaves form a sludge that affects the contact between the wheels of some trains and the track. This contact is firstly essential to know the position of the trains between two signals and secondly allows the trains to brake without sliding.



Beyond the recovery zone (area where any obstacle* is prohibited), the regulations require the removal of all trees located in the safety zone whose diameter, 40cm above the ground, is greater than 10cm. Otherwise, it is necessary to protect these obstacles* with barrier-type safety devices.

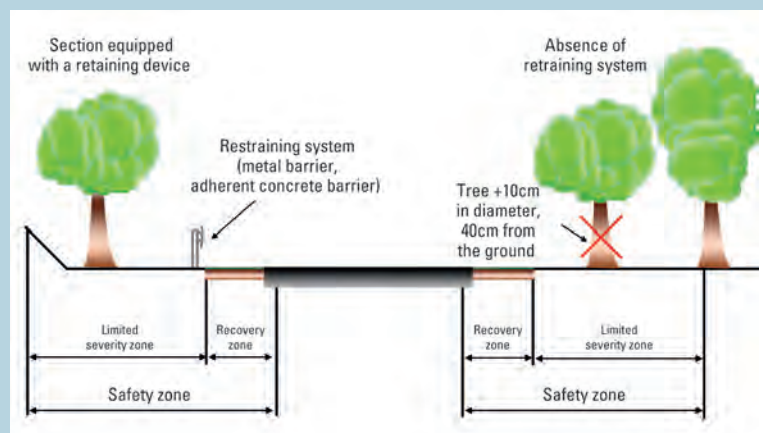

According to the technical guide entitled *Traitement des obstacles latéraux sur les routes principales hors agglomération*, Cerema 2002. Source: Cerema.

..... Increase in the number of habitats

Like the developments that can be envisaged on fauna passages, green rights-of-way are also available spaces that can benefit from the development of structures conducive to the reception of biodiversity*. The objective is to offer maximum habitat possibilities for a maximum number of species. These shelters can be varied

and range from a simple stack of branches (④ next page), pile of wood or stones, to more complex structures such as hibernaculums* (⑤ next page). The variability of structures can also be reinforced by different devices to vary micro-climates and thus constitute different micro-habitats.

The attractiveness of these facilities is significantly improved when, at the same time, they are bordered by a favourable vegetation development such as a border of tall grass.



④ Construction of a swath on the edge of the A150 motorway.
 Source: OGE - Vincent Vignon.

Depending on local characteristics, wetlands (ponds, wetlands) may also be considered.

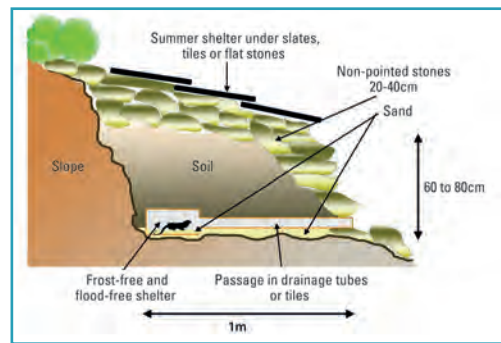

⑤ Schematic diagram of a hibernaculum* in a slope.
 Source: according to Aménagement d'abris à reptiles, Daniel Guérineau, Marie-Claude Guérineau.

Adapted management

Each infrastructure manager is responsible for maintaining and managing its rights-of-way. The terms of its interventions associated with the ecological conditions of the environments result in varying degrees of value of the biodiversity* of its spaces, in particular as a habitat or corridor.

While this day-to-day management can be optimised to take biodiversity into account as well as possible, or even promote it, it must also incorporate technical constraints, in particular those related to safety.

This management must also take into account new issues such as invasive exotic species, health risks, increased visibility of certain plants often considered undesirable by users (e.g. thistles, nettles), the risk of fire or the national Ecophyto¹⁶ plan. Management that is more in line with environmental concerns also requires specific training for management service staff (explanation of the approach and technical aspects).

To favour biodiversity, several elements must be considered.

Handing over to nature

While regular interventions are justified in certain environments and as close as possible to roadways, it may be interesting to **hand over to nature**, that is to say to avoid any intervention, in other areas (e.g. top of excavated embankments). This principle must also be compatible with safety and maintenance requirements.

Limiting chemical disturbances

Regarding plant protection products, Article 68 of the French Act on Energy Transition and Green Growth, voted on 18 July 2015, has prohibited the use of plant protection products* on roads, since 1 January 2017. The Act nevertheless provides for exceptions, limited to "narrow or difficult to access areas, such as ramps, interchanges, central reservations and structures, for which the prohibition of plant protection products cannot be envisaged for reasons of safety of staff and users, or disproportionate constraints on road operations".

16 Pharmaceutical product reduction plan.

For railway management, operating conditions make it difficult to use certain alternative techniques to weed-killers. However, SNCF Réseau has reduced its consumption of plant treatment products by changing products and their equivalent effectiveness at lower doses, but also by changing practices. More efficient equipment such as weeding trucks and trains equipped with a GPS linked by 3G with the geographic information system for vegetation control (SIGMA) are used. Previously identified watercourses are also subject to a buffer zone excluding plant treatment products.

Developing management that fosters biological diversity

The challenge is to find the right balance between the management actions necessary for the proper operation of the infrastructure and the ecological functionalities sought. Many guides have been published on this type of management, which must be defined according to local issues. Among the management elements that may be concerned are:

■ Zone-differentiated maintenance

It makes it possible to reconcile management requirements with a diversification of environments along a transversal and longitudinal axis.

At the transversal level, management is all the more extensive when the infrastructure is far away. For motorway infrastructure, there are four identified zones (⑥):

- **zone I** green rights-of-way are defined by their closeness to the transport infrastructure. It mainly plays a role related to the **safety of road users**, in particular by allowing good legibility of the road, its surroundings and signs;

- **zone II** green rights-of-way support **the functionality of the road** and actively contribute to its good visibility. It participates in the stability of the slopes;

- **zone III** green rights-of-way have fewer issues relating to user safety or road techniques. On the other hand, it can contribute to the **promotion of biodiversity* and landscapes**. It can therefore shelter specific fauna and flora and participate in the enhancement of the route. It also contributes indirectly to the safety of users by reducing the risk of monotony at the wheel;

- finally, **zone IV** green rights-of-way may have issues relating to the **porosity of the infrastructure in relation to its environment**. Should the manager be required to reduce the risk of collisions caused by wildlife crossing the infrastructure, this zone shall be subject to special maintenance to avoid damage to the fencing. Otherwise, management can be handled on a case-by-case basis, depending on the residents of this green right-of-way (agricultural area, populated area, etc.). When there are few issues in this area, more extensive management, similar to that planned for zone III, may be proposed.

For railway tracks, vegetation management is organised according to three zones, "rail and track", "proximity strips" and "approaches" (⑦ next page).

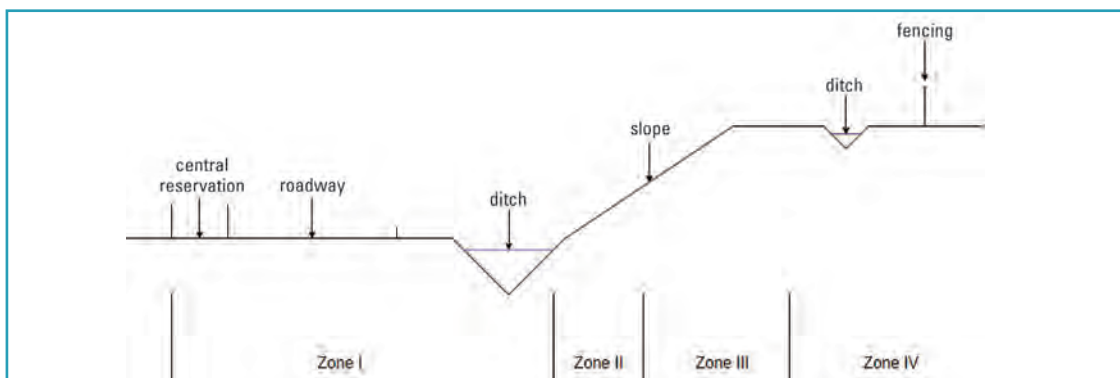

⑥ Schematic cross-section of a green right-of-way of a road infrastructure. Source: Cerema.

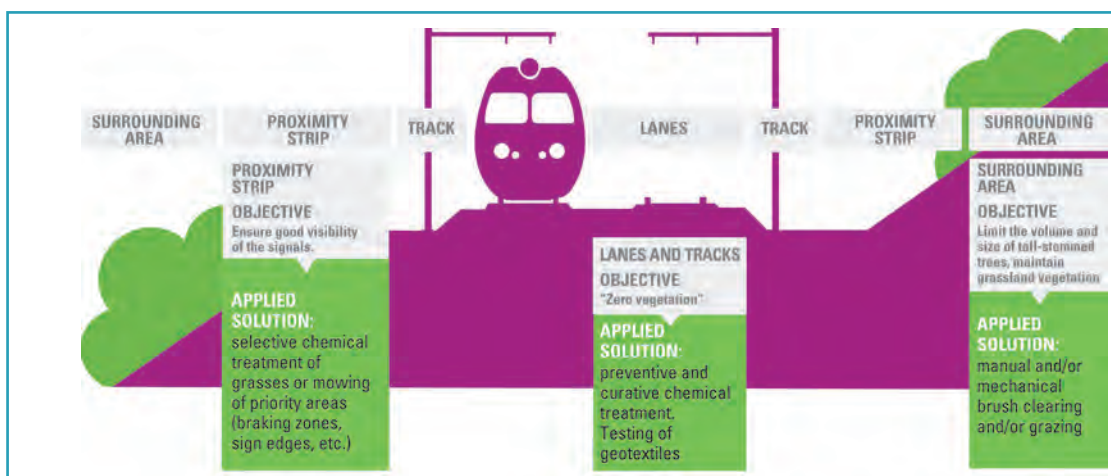

7 Principle of management of railway infrastructure and its rights-of-way.

Source: <https://www.sncf-reseau.fr/fr/a-propos/developpement-durable/environnement/biodiversite>

Longitudinally, it may also be interesting to work on a tighter scale and apply different maintenance to each zone (mosaic maintenance) alternately along the infrastructure (8). This type of management also makes it possible to conserve refuge and feeding habitats during maintenance operations.

Ecological mowing

Mowing is preferable to shredding even if in practice, given the difficulty of implementing mowing, almost all managers opt for shredding. Shredding is more destructive to flora and fauna than mowing. The mineralisation of shredding residues is faster than mowing residues and enriches the environment (however, the diversification of flora requires a depletion of these spaces).

Ecological mowing can be defined as a set of good practices designed to rationalise roadside mowing, so that environmental and economic issues are fully integrated and taken into account in the fulfilment of the objectives of maintaining safety and preserving road assets.

Ecological mowing promotes the preservation of fauna and flora, in order to allow green rights-of-way to play a role as a biodiversity* reservoir or biological corridor.

Proper management of roadsides can significantly increase their floral value and thus their value for biodiversity in general. In addition to a

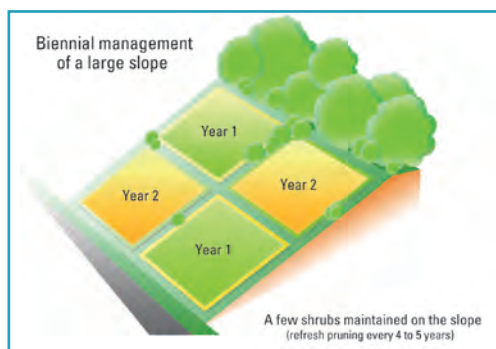

8 Principle of mosaic management on large slope.

Source: Cerema according to OGE.

reduction in the use of plant protection products* mentioned above, the following recommendations can be made:

Cutting height

Overall, it is advisable to increase the cutting height. Extensive management involving a higher vegetation cut between 10 and 12cm allows green rights-of-way to play a role as a reservoir and biological corridor. Associated with late mowing, it favours, for example, pollinating insects because of the flowering of the plant canopy. It is also beneficial to orchids. Indeed, by increasing cutting height from 4cm to 10cm, orchid rosettes* are preserved. The plant does not exhaust itself by regrowing its rosette. It should also be noted that the height of vegetation after 3-4 weeks is identical regardless of the cutting height.

Late mowing

This mowing is carried out from mid-July and if possible at the end of summer, to allow the life cycle of both animal and plant species to roll out.

The plant species can thus reach the flowering and then fruiting stages, making it possible to preserve floral diversity from one year to the next, but also associated pollinators. Mowing must also not be too late, at the risk of destroying the orchid rosettes* that appear in the autumn.

Late mowing also helps **control management costs**, by reducing the frequency of mowing and increasing its height. Indeed, when the mowing height is between 10 and 12cm, the risks of projects, wear or breakage of tools are limited.

This management therefore makes it possible to increase the life cycle of mowing equipment.

Frequency

An excessive frequency of mowing favours the development of annual weeds and nitrophilic floral species. It is detrimental to floral diversity. It contributes to the eutrophication of the environment and the standardisation of flora.

Frequent shredding also leads to destruction of spider webs, nests, etc. It also eliminates the nectar and pollen resource for flower-dwelling insects and causes micro-climate changes affecting low-mobile arthropods.

The following road right-of-way management plan is proposed:

Types of space	Frequency	Period	Height
Safety strips	As often as necessary (usually 2 to 3 times a year).	Depending on the vegetation height.	Higher than 10 - 12cm over a 1.5-metre pass.
Safety clearances (crossroads, turns, signs, etc.)	As often as necessary.	Depending on the vegetation height.	Higher than 10 - 12cm.
Berms and ditches	Once a year to ensure the functionality of the passage.	After the summer period (late mowing).	Higher than 10 - 12cm.
Slope	Once a year [May not be mown on the motorway network subject to legal clearing obligations or other regulatory obligations].	After the summer period (late mowing).	Higher than 10 - 12cm.
Along fences	Once a year.	After the summer period (late mowing).	Higher than 10 - 12cm.

■ Export of mowing or shredding products

By limiting decomposition on site, the export of biomass makes it possible to avoid eutrophication of the environments and in the long term modifies the floral balance (in favour of oligotrophic* species such as orchids, at the expense of the most

competitive grasses). It reduces the frequency of mowing and clearing of the hydraulic network. It requires suitable equipment (suction and collection system), a specific site organisation with the prior collection of waste and transport of biomass to recovery facilities (composting or methanisation).



The Carmen project

Characterisation of polycyclic aromatic hydrocarbons (PAHs) and metals in roadside mown grass for methanisation, launched in 2015. The purpose of this project is to study the possible obstacles to the use of the methanisation of mown roadside grass (use of the final product: compost), linked to the contamination of this biomass by pollutants from traffic.



Mowing equipment. Source: DIR Ouest.

The results show concentrations of pollutants below the limit values prescribed by the standard for the quality of compost. This biomass could thus be a local resource adapted to small methanisation installations (cost-benefit analysis).

Reference: Isabelle Zdanevitch, Jeanne Lencauchez, Léa Duffo, Christophe Pineau, Laura André, Thierry Ribeiro, CARMEN, *Caractérisation des HAP et des métaux dans les herbages fauchés en bord de routes pour la méthanisation*, ADEME, 2018.

■ The fight against invasive alien species

The edges of roads and railway tracks offer favourable conditions (disturbances, land inputs, etc.) for the establishment and development of alien species, which can be invasive, disrupt the proper functioning of the infrastructure and degrade its role as habitat or corridor. The destruction of vegetation and soil during the production and frequent maintenance of edges favour these species, which are usually colonisers and less sensitive to disturbances (shredding, treatment, compression, etc.) than native flora. Preventive actions include pre-cleaning machinery, limiting the movement of soil, and rapidly vegetating areas at risk by selecting local seeds free of invasive species.

The manager must carry out prospection work and inventories of these species, as well training staff in these issues. In the event of outbreaks, a management plan must be defined, including the identification of the technical (management methods), human and financial resources to be provided. The results of the Dynarp (*Dynamique paysagère des renouées sur les infrastructures de transport*, Ittecop 2014-2017) project on Japanese knotweed underline the importance of consultation between local stakeholders.

Management techniques are still experimental for many species and total elimination is a goal that is difficult to achieve. Examples include: avoidance of colonised areas, manual mowing (brush cutter, pruning shears, or other tools for exporting all the cut biomass), installation of a root screen, manual digging, mechanical flushing, extensive grazing (sheep or goats), etc.

Informing and training staff of contractors and their service providers (landscapers, maintenance, etc.) about ecological management

The aim is to train and structure a whole range of professions around ecology, in conjunction with experts in this field (scientists, consultancy firms, managers of natural areas, etc.). Care must also be taken to keep management objectives in mind so as not to destroy measures simply by neglect or omission.

SNCF Réseau strengthens "vegetation" expertise in maintenance establishments: "vegetation experts" are thus responsible for establishing an ecological maintenance plan and ensuring the consistency of all interventions in their area (from private companies to internal weeding and clearing resources).

Designing co-constructed management plans with local ecologists and stakeholders

Enabling a medium-term and renewable vision, the management plan contributes to responding, on fallow land in particular, to the ecological challenges of each identified environment and guides its quality by determining objectives, means and management actions to be implemented.

A "framework" management document can also be developed and adapted locally. This document provides a comprehensive approach to the quality and diversity of rights-of-way. It also makes it possible to better identify the measures to be implemented in order to integrate the corridor issues on a sufficiently large scale, while taking into account local issues such as the presence of protected or invasive species.



Ecological maintenance directive for green rights-of-way, written in collaboration with DIRO/Cerema

The first maintenance directive for green rights-of-way was developed in 2008, accompanying the creation of DIR Ouest. It laid down the principles of a maintenance doctrine common to all districts according to an itinerary principle.

The evolution of the regulatory context, the development of new management practices and the supply of maintenance equipment led to the revision of this directive in 2015, and then in 2019, with the guiding principle "taking into account ecological management of rights-of-way and the preservation of the environment". It is part of a more comprehensive approach to enhancing current heritage maintenance policies (roadways, structures, green and blue rights-of-way).

This directive consists of a general document presenting the principles of differentiated management* in terms of zoning, maintenance policies and their implementation methods (planning, training, health and safety means). It consists of a number of thematic sheets presenting good practices on specific topics such as mowing, brush clearing, management of invasive plants or management of wooded assets.

Districts must carry out their annual maintenance plan for green rights-of-way in accordance with this directive.

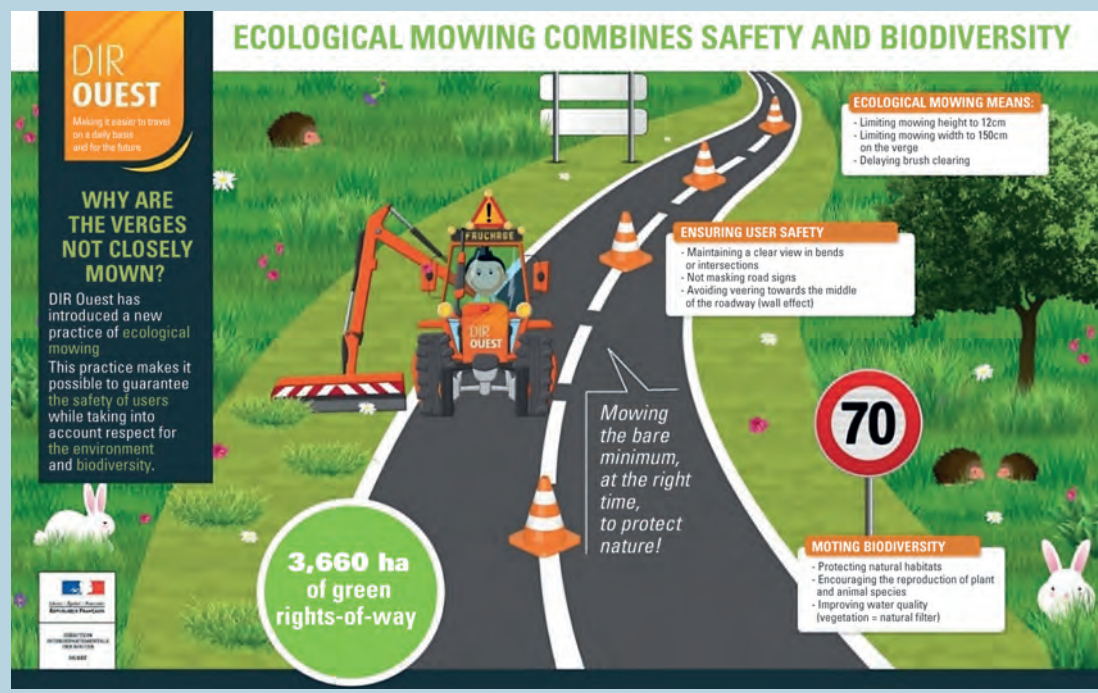

How to ensure fauna's access to rights-of-way while ensuring its protection? Fences and barriers

The conditions for the installation of fences and barriers along rights-of-way¹⁷

Fencing, regulations and general recommendations

There is no general national regulation requiring a network manager to erect fences along traffic lanes. However, the State and local authorities, as bodies responsible for the road network, have a statutory obligation to ensure the safety of road users and the maintenance of roads. According to case law, this normal maintenance of the roads includes, near forest areas home to large fauna and in areas where the passage of large animals is commonplace:

- at least, on each lane, marking danger zones;
- on motorways or high-speed train lines only, the development of these zones, to avoid the risk of wildlife vehicle collisions.

More generally and beyond the legal aspects, it is recommended to equip all high-speed railways and high-traffic road infrastructures with more than two carriageways.

Fences, on the other hand, have the disadvantage of creating a physical barrier that limits or even prevents the movement of wildlife on either side of the infrastructure. This is also why these devices are to be reserved for these categories of infrastructure (dual carriageways, LGV high-speed trains) for which the issues for wildlife are the highest and the risks for users and equipment are the greatest.

For the smallest infrastructures with low traffic density, fencing should generally be avoided or reserved for specific problems safety or wildlife protection issues (localised collision hotspot).



Fawn. A89 motorway (Corrèze).

Source: Vinci Autoroutes/ASF network.

Otherwise, the barrier effect could have more serious consequences on long-term population survival than traffic mortality.

However, in the case of particularly endangered species for which the potential for collision mortality could affect the survival of the population or core population, it is absolutely necessary to prevent access to the roadway. In this case, it may prove essential to prioritise the potential risks of wildlife vehicle collision which are partly dependent on the level of traffic in order to better target the linear footprint to be treated. Remember that on smaller infrastructure, warning devices triggered when animals approach it may also in some cases be considered to compensate for the absence of fencing (see fact sheet no.19).

17 Additional information is available in the following report: *Clôtures routières et ferroviaires & faune sauvage. Critères de choix et recommandations d'implantation*, Cerema 2019.



The protection of a low gauge (bi-directional) road is not usually recommended. Occasionally, however, it may be necessary to protect certain species.

This is particularly the case for otters, beavers or European mink at intersection points between roads and the rivers or wetlands they frequent. These three species are in fact particularly prone to road wildlife vehicle collisions which, for the last core population of the European mink, are a real survival issue.

When a stream or wetland frequented by one of these species is intercepted by infrastructure, it is recommended to prevent access to the roadway for these species by placing fences along and on each side of the road. However, it is essential beforehand to ensure that these fences are associated with a structure allowing the crossing of the road by the species throughout the year (waterway structure equipped with a dry-standing area or a bench* set on the ten-year flow, dry conduit).

The fencing should be positioned over the entire wetland at risk. In the case of a point crossing of a watercourse, even if the wetland associated with the watercourse is located, the fencing must cover at least 50m on either side of the watercourse.

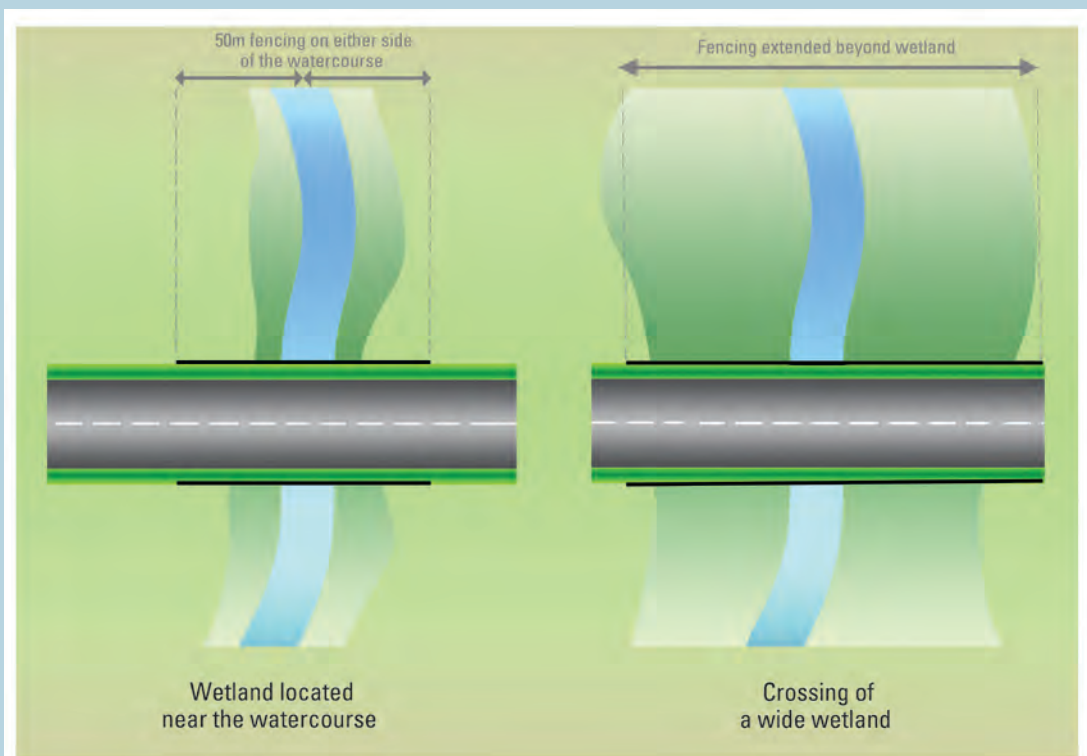

Schematic diagram of fencing for beavers, European mink and otters, near a dedicated fauna crossing. Source: Cerema.

Fencing and fauna passages, two inseparable measures

Where fencing is essential and to limit fragmentation, there should crossing points for species.

The installation of fences is therefore most often inseparable from the construction of fauna passages. The advantage is twofold, since the fences will both limit wildlife vehicle collisions and guide the species to secure crossing points.



Bouffard, M., Leblanc, Y., Bédard, Y. & Martel, D., *Impacts des clôtures métalliques et des passages de la faune sur la sécurité routière et le déplacement des orignaux le long de la route 175 au Québec*, *Le Naturaliste canadien*, 2012.

Wildlife monitoring conducted during this study showed that the installation of a fence as part of the development of highway 175 over 67km reduced the occurrence of moose within the road coverage by more than 95%, reducing the annual frequency of collisions with vehicles from 7.5 collisions (in 2006 and 2007) to none (in 2008 and 2009) in the fenced area. At the same time, moose's use of fauna passages increased by 48% between 2009 and 2010 (from 189 to 279 passages).

An installation to maintain access of the rights-of-way to fauna

In most cases, fauna fencing is located on the outer limits of infrastructure coverage to facilitate operation and to mark the property line. This makes many green rights-of-way inaccessible to wildlife and limits their ecological valuation. It can also increase the risk of wildlife seeking

to cross the fence to reach environments on the other side.

In fact, it is now recommended, where possible, to place fauna fences as close as possible to the infrastructure while respecting management constraints (maintenance, safety) (1). As a supporting measure, it is advisable to place an anti-intrusion device (grass fence, rock blocks, defensive hedge) 0.5m inside the coverage to clearly identify its limits.

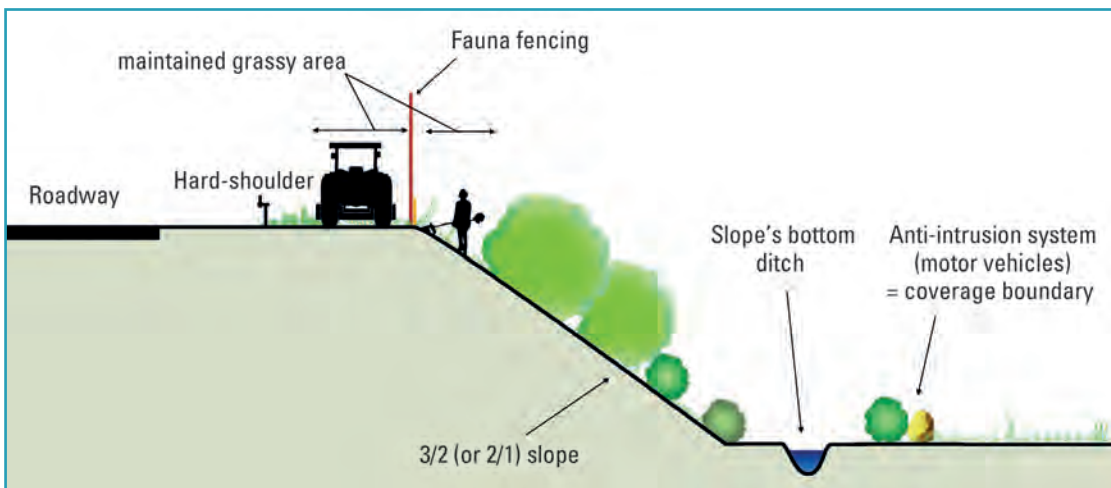

1 Position of the fence at the top of the slope to integrate green rights-of-way into species' habitats and ensure natural longitudinal continuity. Source: Cerema.



Fencing positioned at the coverage boundary preventing wildlife from accessing green rights-of-way. Source: Cerema.



Fencing positioned as close as possible to the road and allowing free access of wildlife to green rights-of-way. Source: Cerema.



Constraints related to user safety impose a safety zone (more or less depending on the authorised speed on the infrastructure), within which certain restrictions must be imposed and which includes:

- a recovery zone where any obstacles* or equipment are prohibited;
- a limited severity zone where obstacles* are forbidden which are not fusible (do not deform sufficiently or do not break in the event of an impact [maximum admissible moment 570daN.m]), some ditch categories, cut or fill with steep slope, etc.

As flexible barriers, fences are therefore allowed in the limited severity zone. However, when the infrastructure is affected by safety devices (metal slide, adherent concrete barriers), care must be taken to leave a distance of 1-2m, in order to ensure the safety of people sheltering at the back of this device.

As part of the Motorway Recovery Plan, Vinci Autoroutes has carried out upgrading* actions called "Corridors" on its network. The objective of these actions is to open green rights-of-way of part of the motorway to wildlife (making environments attractive to wildlife) by bringing the fences closer to the roadway. New "large fauna" fencing (progressive welded meshes 2 metres high) is set up in consultation with the operator, taking into account the following constraints:

- width of the coverage of the corridor > to 5m;
- no installations on a steep slope;
- equipment constraints: road signs, crash barriers, downcomers, ditches, ponds;
- vegetation maintenance constraints.

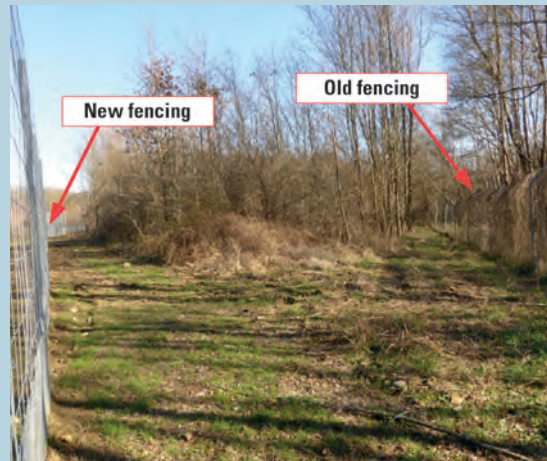

Example of released right-of-way between the new fencing to the left of the image and the old one to the right.

Source: Cerema.

The old fencing is completely removed or kept, but in this case it is made permeable by regular openings every 100m and in strategic places (in line with transversal corridors, hedges, woods, rivers, etc.) and in corners.

As part of upgrading*, special arrangements such as the upgrading of existing service gates or fencing returns on structures were also necessary to ensure the continuity of the fenced heights.



Return on civil-engineering structure.
Source: Cerema.



Height extension on service gate.
Source: Cerema.

Some recommendations for approaching the structures

Next to a fauna passage, when the fencing is not positioned as the extension to the structure head (i.e. like the diagram 1 below), it should at least form a funnel (see diagram 2 below)

for easy guidance of the animals towards the structure opening and to reduce the "tunnel" or "corridor" effect as much as possible (see diagram 3 below).

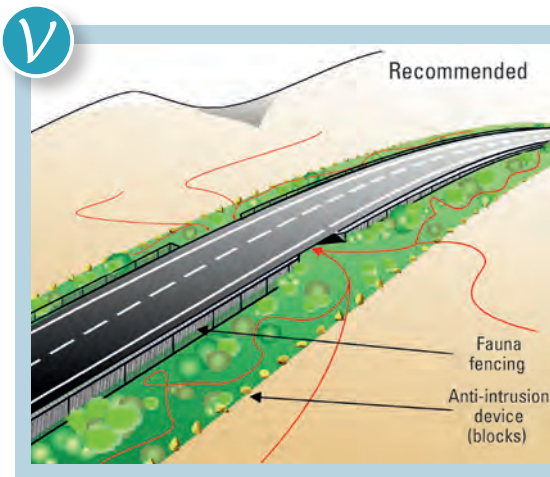

1 Layout diagram of fencing allowing wildlife to access green rights-of-way and be guided to crossing structures. Source: Cerema.



2 Layout diagram of fencing that does not leave green rights-of-way accessible to wildlife. Approaching the structure, even if the rights-of-way are not accessible, the addition of "funnel-shaped" fencing makes it possible to guide the fauna towards the entrance of the passage. Source: Cerema.



3 The layout of the fencing does not leave the green rights-of-way accessible to wildlife. Its layout near the entrance of the structure creates a corridor effect that deters wildlife. Source: Cerema.

While the continuity of the fencing is essential, care must also be taken to ensure the continuity of the rights-of-way. Some precautions are thus necessary when rights-of-way cross, for example, a secondary road. In this case,

- when the infrastructure passes over the secondary road, care will be taken to arrange the fencing so that there is a clear passage between the fencing and the structure. However, this is only possible when the structure is in a large enough embankment (❷);
- when the main infrastructure passes under the secondary road, in order to avoid that the stone pitching* of the structure does not form an obstacle* to the continuity of the rights-of-way, especially for small fauna, it is necessary to provide for additional coverage between the base of the stone pitching* and the roadway or create pitching areas within it. (❸)

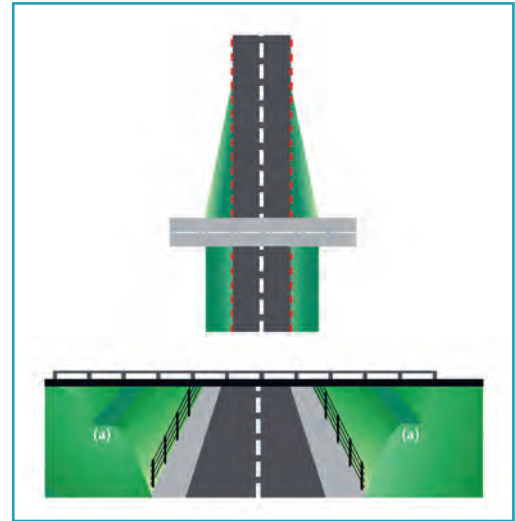

❸ Stone pitching of the structure which remains passable by wildlife by positioning the fence at the bottom of the stone pitching and creating pitching areas within it (a). Source: according to Office fédéral des routes suisses (2000).

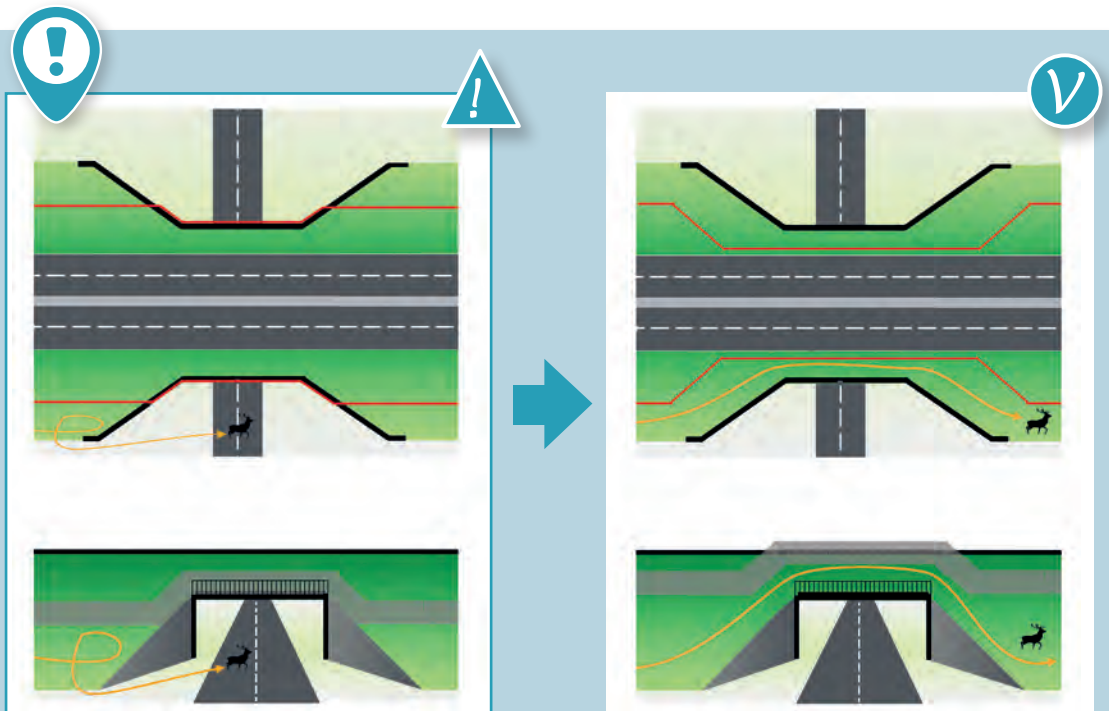

❷ When the infrastructure passes over a secondary road and the embankment is large enough, the fencing must maintain a crossing space above the structure to avoid wildlife crossing onto the secondary road with the risk of wildlife vehicle collision. Source: Cerema.

Points of vigilance to ensure a maximum seal against wildlife

First and foremost, fencing must always be installed on both sides of a road or railway track.

Faulty installation and fencing maintenance failures are the main sources of device malfunction.

During installation, special attention must be paid to certain points.

■ **At the foot of the fence**

The best way to make foot of the fence impassable is to bury it for up to **30 to 50cm**. This precaution is recommended for large fauna fencing and is essential for small fauna fencing.

When the decision has been taken not to bury the lower part of the fence (not recommended), it must be pinned to the ground to prevent burrowing animals from lifting it up and accessing the infrastructure coverage. The pinning system should be adapted to the pressure of the wildlife present and to the nature of the soil. Reinforced mesh folded and pinned to the ground may also be necessary.



Entry point into the coverage on a non-pinned wire mesh section.
 Source: Mathieu Narce, IMPCF.



Unburied fence with progressive meshes, not pinned and leaving small fauna free access to the infrastructure coverage. Source: Cerema.

■ **Next to connections to concrete structures or access gates**

- On fauna underpasses, the fencing should, if possible, be continuous and, in all cases, there should be no open access points to the road coverage. When it is possible (a high enough embankment above the structure), a space is maintained above the structure (see diagram 1 in the previous chapter). Otherwise fencing must be connected to the railing of the deck of the structure or to the return walls (or even extended along), ensuring that the anchorage points leave no spaces.
- Care must also be taken to ensure that the position of the fencing always allows access to the entrance to the structures, especially small fauna passages.



Large fauna fencing bypassing the structure head.
 Source: Cerema.



Fencing preventing wildlife from accessing the structure.
 Source: Cerema.



Amphibian fence bypassing the structure head.
 Source: Cerema.



Return fence running along the walls and connected to the railing of the structure. Source: Cerema.

- Gates are very often entry points for small fauna that gets through the open spaces between the ground and the bottom of the gate. In this case, it is recommended to install a rubber 'skirt' or fit the entrances with a concrete or metal threshold (4 and 5). For gates, the installation of access steps could also reduce the possibilities for wildlife to enter (6).

For amphibians, which tend to run along fences and for which an opening of a few centimetres is sufficient for them to get through, it is preferable to set up gutters equipped with a cattle grid to avoid access to the gate where the most possibilities of entry can be found. Gentle side slopes will allow amphibians to exit the device (7).

For individuals arriving head on to the gate, a ramp should be installed to prevent them from climbing from the cattle grid to the gate (8 and 9).



4 Gate equipped with a "skirt". Source: Cerema.



5 Gate equipped with a concrete threshold. Source: Vinci Autoroutes/ASF network.



6 Gate equipped with access steps to reduce the possibilities for wildlife to enter. Source: A. Clevenger.

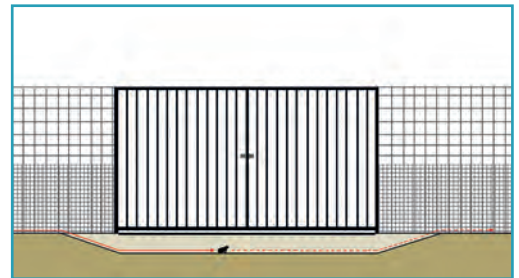

7 Diagram of the layout of a gutter next to a gate. Source: Cerema.



8 Sloping gutter. Source: D'Agostino/Écosphère.

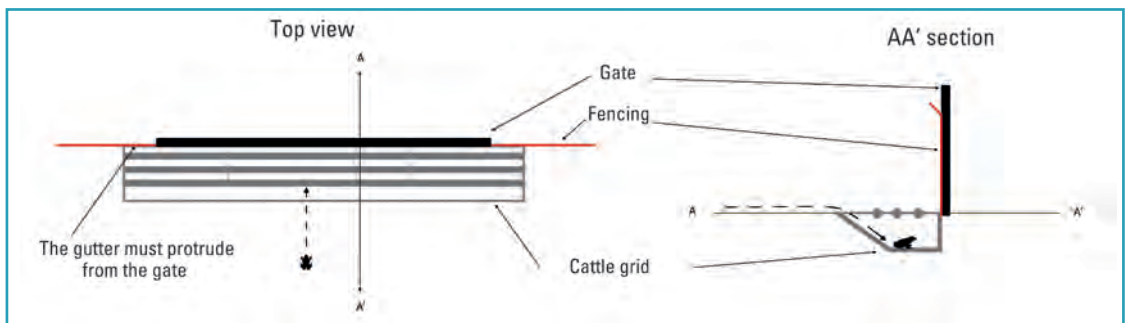

9 Schematic representation of a cattle grid equipped with a ramp to prevent access by amphibians. Source: Cerema.

• For braced fences (10), it is recommended to set up:

- either a gutter (see above) when amphibians are not involved,
- or a concrete threshold together with, at the foot of the braced fence as close to the ground as possible, a metal bar or tension cable (11).

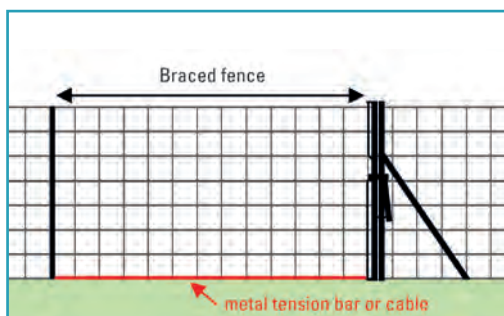

11 Schematic representation of a braced fence equipped with a metal tensioning cable or bar. Source: Cerema.



10 Correctly wired braced fence without a concrete threshold or bar or tensioning cable. Source: JBS Métallerie.



Space available under the gate allowing small fauna to pass. Source: Cerema.



Incorrect connection of the wire fence to the structure allowing wildlife free access to the coverage. Source: Cerema.



Broken fine mesh fence providing amphibians access to the coverage through the gate. Source: Cerema.





Poor connection of the fence that passes under the structure and reduces the space available to wildlife. Source: Cerema.



Opening in the fencing allowing access to the coverage. Source: Cerema.

■ Ditch crossings

When the fencing is crossed by a ditch, the continuity of the fences can be ensured by different types of devices:

- ditch grids: for large fauna, the spacing of the bars must not exceed 12cm. The bars can be horizontal to limit obstructions. When these devices also offer protection against intrusion by small fauna, they must also be covered by a small fauna mesh (12). They can also tilt (one-way from upstream to downstream) to avoid obstacles



12 Example of devices put in place to ensure the continuity of fencing: removable grid on ditch. Source: Cerema.

and facilitate cleaning. In this case, the hinge must allow uplift at the slightest pressure and the slope must be steep enough to ensure a flushing effect. When the risk of obstruction is too high, it is preferable to use check valves (13) or thresholds (14 next page);

- valves or a tilting check plate are retaining elements that let water through while stopping wildlife from passing;
- The thresholds are 60 to 80cm deep ditches that form a barrier for smaller animals unable to jump across them.



13 Check valve on downcomer preventing wildlife from accessing the coverage. Source: P. Fournier, GREGE.

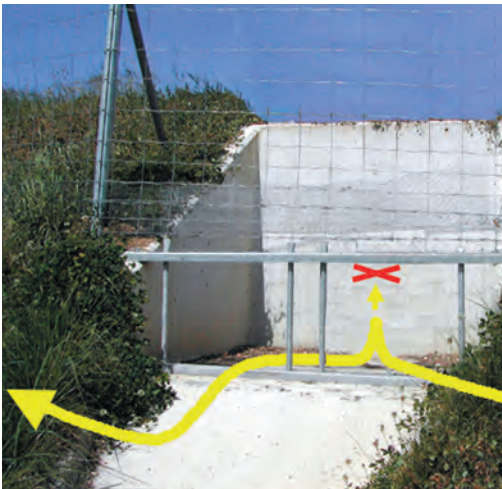

14 Connection to concrete structure.
 Source: P. Fournier GREGE.



A discontinuous fencing device providing an entry point for smaller animals (amphibians). Source: Cerema.

■ On access roads to infrastructure coverage

Similarly, access roads to fenced infrastructure are entry points for wildlife. To reduce access possibilities, a cattle grid can be added (15): it is a 2 to 3m wide device consisting of a 30 to 50cm deep ditch covered with a metal structure. In France, they can only be found on secondary roads. Installed on a road, a path, at service gates, a cattle grid allows continuous vehicle and pedestrian movement, whilst preventing animals passing (animals never step onto a surface above an empty space).



15 Cattle grid installed to prevent wildlife from accessing the infrastructure from a secondary road.
 Source: Cerema.

The openwork (the grid) is made using metal rollers (or fixed bars) spaced 8 to 10cm apart.



16 Pedestrian gate whose hinges are offset (closer to the post at the bottom than at the top) so that it closes automatically without intervention.
 Source: Cerema.

Some recommendations:

- provide a water drainage system in the pit;
- provide an exit for small fauna that may fall accidentally into the pit: the installation of openings combined with ramps that extend the fence allows animals to move along the road without being able to enter infrastructure coverage and to escape from the pit, if they do fall in;
- ensure regular maintenance.

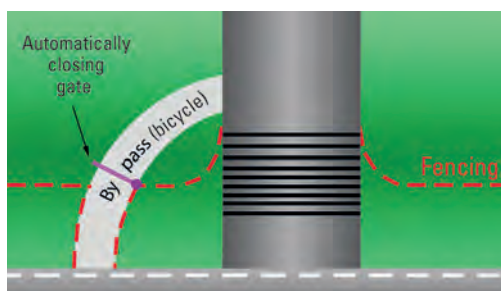

17 Bypass and gate for bicycles and pedestrians.
 Source: D. Chevalier, SETRA.



Note: In some cases, the danger that the cattle grid may represent for cyclists, motorcycles or pedestrians leads to abandoning this type of feature, but there are solutions that make it possible to overcome this risk of falls: signage, by-pass with gate (16 and 17 previous page).



The price of a galvanized cattle grid partly depends on the use and in particular the weight of the vehicles likely to cross it. A system of 3 or 4m x 2m galvanized steel allowing the crossing of 4 wheeled vehicles can thus reach €3,000 to 5,000.

■ Along interchanges and extremities

Interchanges and extremities are also access points for wildlife. To limit access, even if it is not possible to totally seal off a road infrastructure, it is recommended:

- at the extremities:
 - to connect the fencing to a crossing structure (bridge, viaduct, etc.),
 - to extend the fencing by at least 500m beyond the crossing point, making sure to close it on a straight, clearly visible section and supported by road signs;



Example the layout of fencing next to an interchange. Source: Google Earth/Cerema.

- on interchanges:
 - to raise the fencing along the interchange access roads.

■ Next to drainage ponds

Rights-of-way may include facilities used for the operation of the road or railway which, when in favourable environments, is likely to attract a certain number of fauna species. This is particularly the case for water treatment ponds on road infrastructure, which are often colonised by amphibians, birds and large numbers of insects, such as dragonflies. For terrestrial mammals, however, access is more difficult, because these ponds are necessarily fenced off for safety reasons. However, care must be taken to ensure they are not accessible to burrowing animals (ground reinforcement).

For small aquatic species that can access them, these spaces can potentially act as shelters and participate in the functionality of the ecological network, particularly of "Japanese step structures"¹⁸.

However, it seems that chronic mortality due to the mutagenic effects of hydrocarbons cannot be excluded, especially for amphibians. It is therefore difficult to evaluate the concept of cost/benefit for these habitats developed for species.

In general, it is therefore recommended, where possible, to set up a succession of two types of ponds (19 next page):

- a technical pond (19) for water treatment (sized for a return two-year rainfall over two hours) which is used to store accidental pollution and treat chronic pollution (hydrocarbons, etc.) and seasonal pollution (salt). This pond with concrete bottom is fenced to prevent amphibians penetrating (concrete wall, metal, plastic) and to deter wildlife. This pond must also be equipped with escape exits for individuals who have nevertheless managed to enter it;

¹⁸ Succession of favourable environments for a species which, although distant from one another remain close enough so that the species moves from one to another, therefore creating a broken corridor.

- a rainwater storage pond (⑳) (sized to complete the volume up to the ten-year rainfall level) with zones kept underwater (over-dredging or raising of the outlet point) which remains accessible to amphibians (installation of a safety fence that can be crossed by amphibians). Although these are technical facilities, these ponds can be valued for certain faunistic species as part of the project's compensatory measures.

When this solution is not chosen and a single pond (ensuring treatment and hydraulic regulation) is built, it is proposed to:

- make the pond inaccessible to amphibians, if there are relatively close breeding habitats on the same side of the infrastructure;
- allow amphibians free access to this pond, in zones where alternative environments are rare or absent and where amphibian populations have not been identified nearby.

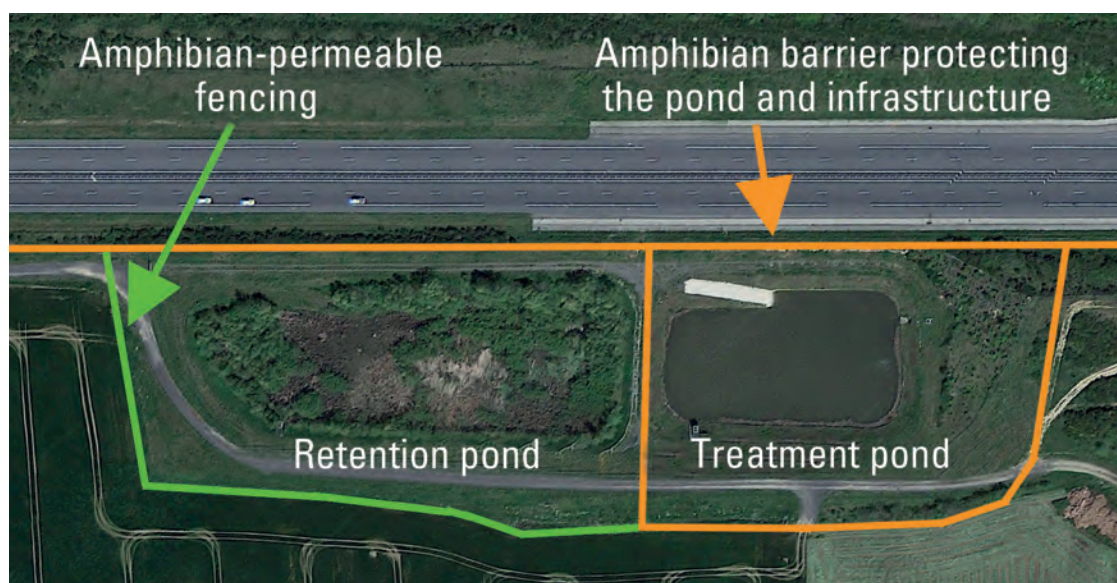

⑱ RN 59 section Saint-Clément Azerailles. To the right of the photo, the treatment pond is fenced, making it inaccessible to amphibians, while the retention pond to the left of the image is accessible to them (amphibian-permeable fence). Source: Cerema.



⑲ Treatment pond equipped with amphibian fences. Source: Cerema.



⑳ Retention pond equipped with amphibian fences. Source: Cerema.

When the ponds are fenced off, the seal must be maximum, otherwise the design defects are exploited by amphibians that then quickly colonise the environment. In order to ensure maximum sealing, it is preferable to use continuous barriers made

of concrete, metal or smooth plastic, partly buried and equipped with a flap. At the gate, rather than a rubber "skirt", it is preferable to install a gutter equipped with a cattle grid (see previously "Next to connections to concrete structures or access gates").



Treatment pond equipped with a concrete barrier with openings allowing free access to the pond by amphibians. RD 1004 (Bas-Rhin). Source: Cerema.



Opening in the device constituting an entry point. Source: Cerema.

Devices to allow wildlife to leave infrastructure coverage: escape exits

Infrastructure coverage, even when fenced, is never completely sealed and individuals regularly manage to intrude, despite the device. This is particularly the case at certain entry points that cannot be completely fenced off (interchanges) or when openings are created in fencing by the animal itself (e.g. wild boar that lifts the bottom of the fence), by a falling tree, by a maintenance machine, a traffic accident or an act of vandalism.

Once inside the coverage, their return is then more complicated and they do not always have the opportunity to escape. Among the species likely to enter the coverage, large species (badgers, deer, wild boars, roe deer, etc.) then constitute a risk to the safety of users (vehicles or trains). In order to allow these individuals to return to the external environment more easily, it is thus recommended to set up escape routes at regular intervals along the fencing. Escape exits are one-way devices that allow wildlife to leave the coverage without being able to access or return. The frequency and positioning must be adapted according to the analysis of the natural context and the configuration of the fencing. In some favourable areas, escape exits may be more frequent or, on the contrary, more sparse if the environment presents fewer risks.

Several mechanisms exist:

■ Tilting hatch or door system

This device consists of a more or less large sized one-way mechanical hatch depending on the target species (wild boar, badger), which opens only from the inside to the outside of the coverage and which closes automatically after the passage of the animal (effect of weight, mechanism under tension) (21, 22 and 23 next page). This device requires the installation of a concrete foundation raft* or a threshold to prevent the species coming from the outside from burying under the hatch and entering the coverage. If it is a meshed hatch, its mesh must be of the same size as the fence to which it is connected.

When these devices are used, they must, however, be particularly well maintained, since experience has shown that they can, in the long run, get stuck, remain open and have the opposite effect to that sought by creating an additional entry point.

There are also devices equipped with a double hatch combined with an airlock. This airlock is placed in the coverage at the end of a fenced corridor parallel to the fauna fencing. At rest, the two entrance hatches are raised. When the animal enters the airlock, two flaps close and a side panel simultaneously opens, allowing it to escape from the infrastructure coverage. This device is very effective, but requires resetting each time it is triggered by an animal. It is therefore generally associated with a detection system to warn the operator to reset it (24 next page).



21 "Sangli-pass". Source: Cabinet X-Aequo.



22 Escape exit, Vinci Autoroutes network. Source: Cerema.



23 Small fauna escape exit in the Netherlands. Source: Cerema.



24 Double flap system. Source: Cabinet X-Aequo.

Ramp system

This is a device consisting of a vertical wall (wall made of rot-proof wood or concrete) a few metres wide and onto which is backed, on the infrastructure side, a gently sloping earth ramp up to the top of the fence. Wildlife will be able to climb onto this and then jump to escape the infrastructure coverage.

The device is positioned in the continuity of the fencing (25) or positioned back from the fence (26) to encourage its use by the fauna that runs along the fence in search of an exit. These devices are

preferably to be installed in sectors with a low risk of a vehicle's possible departure from the road, as the ramp may act as a springboard for the vehicle and potentially aggravate a possible accident. On the natural environment side, for large fauna, the minimum height of the overhang of the escape route must be 1.8m, increased to 2m in the presence of deer.

€ The price of a ramp can vary from €5,000 to 10,000 depending on the type and the context.

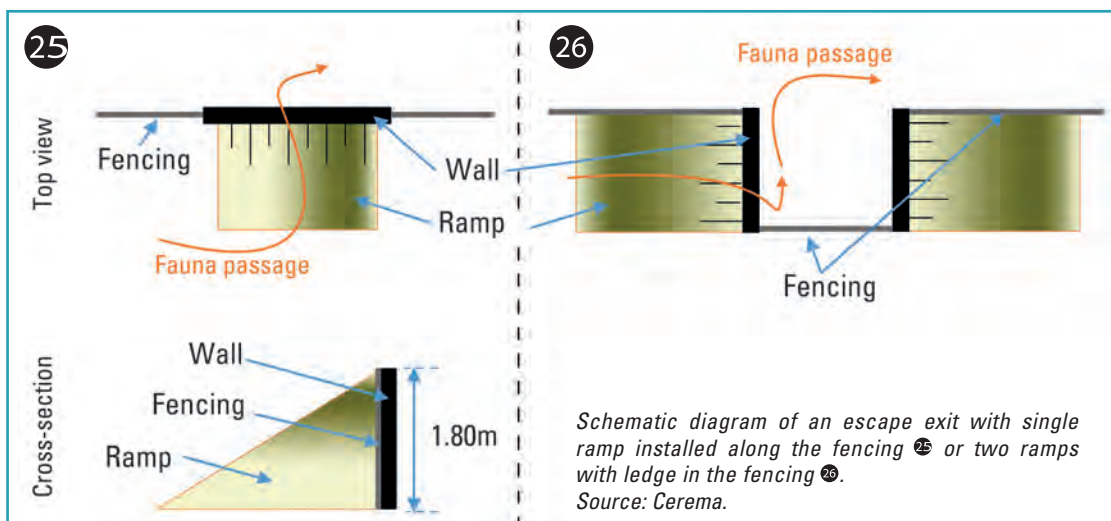



The cost of this type of development is around €5,000 to 10,000 depending on the sizing, the technique and the difficulties of implementation on the site.



Escape exit with a single ramp system (Netherlands).
Source: Vinci Autoroutes.



Escape exit with double ramp (Netherlands).
Source: Cerema.

■ Exit mechanism on structures

When an underpass has winged walls, it is possible at the top of the walls to leave an opening in the fence to allow wildlife to leave the coverage. However, care must be taken not to create an additional access point for wildlife

by making this opening, with respect to the foot of the wall (L2 in the diagram below), at least equal to the height of the fencing (L1 in the diagram below). A return on the fencing along the wall and attaching the posts to the wall will also prevent small mammals from bypassing the fencing.

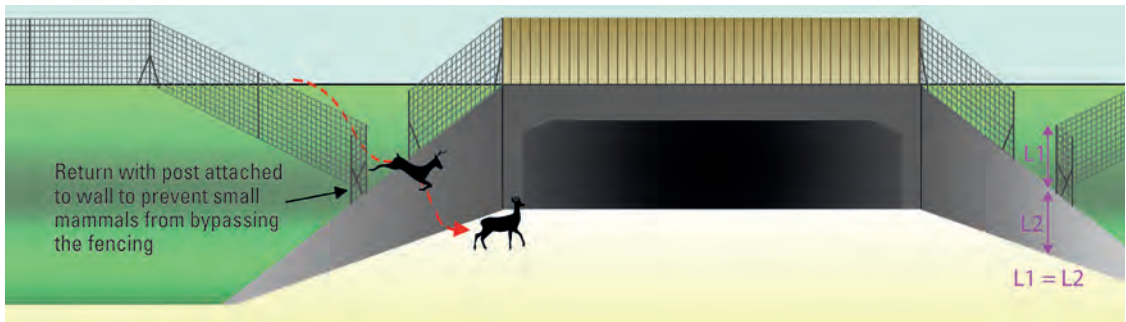

Schematic example of the layout of an escape system at the level of the wing walls of an underpass. Source: Cerema.

■ Additional developments

In order to increase the efficiency of these devices, care is taken to install the escape exit in a corner of the fence (27) or associate it with

a funnel-shaped guidance system (28) or one that is perpendicular to the exit device (29).



27 "Sangli-pass" system installed in a corner of the fence.
Source: Cabinet X-Aequo.



28 Installation of 2 fences guiding towards the device.
Source: IMPCF.

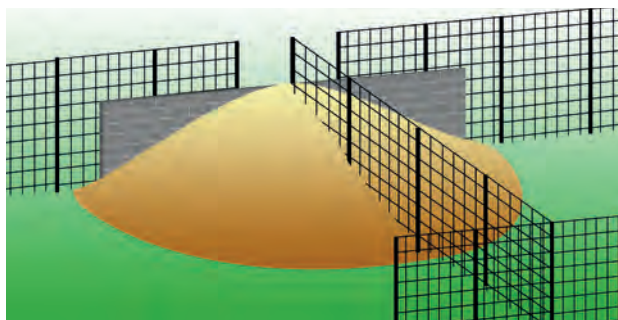

29 Diagram of a guiding fence perpendicular to the ramp.
 Source: Cerema.



Hatch accompanied by a guiding fence.
 Source: Vinci Autoroutes/ASF network.



Specific case of drainage ponds

In the case of ponds with vertical concrete walls or ponds equipped with a geomembrane not covered with topsoil, the installation of plastic mesh is recommended to prevent animals from drowning, allowing them to exit the water by their own means.



Plastic mesh giving some animals a good grip.
 Source: Cerema.

Types of fences or barriers depending on the series of species¹⁹

Fences

Their characteristics (height, meshes, posts) depend on local issues and target species for which:

- the height must be enough to prevent animals from jumping over them;
- the gauge and the solidity of the meshes must prevent them from passing through them.

■ Height

In general, the choice, and in particular the height, is firstly determined depending on the largest mammals likely to be concerned (e.g.: for roe deer, 2m). This height must be constant in the animals' approach direction (from the outer environment towards the infrastructure) and

must take into account the ground configuration (see diagram on next page).

Bird or bat issues can also occasionally lead to choosing high fences (4m) to force species to fly above traffic.

■ Mesh

Some large fauna species are powerful and determined. Fencing must therefore be strong and durable enough to stop them. It is therefore advisable to choose fencing with knotted rectangular mesh whose wire, made in stainless materials (galvanised rectangular meshes), has a diameter of at least 2.5 mm.

See also ¹⁹
 Clôtures routières
 et ferroviaires &
 faune sauvage.
 Critères de
 choix et
 recommandations
 d'implantation,
 Cerema 2019.

The fence must if possible be fixed outside the posts (i.e. on the outside of the infrastructure coverage) in particular to be as resistant as possible to wildlife that tries to enter the coverage from the outside.

The size of the meshes is determined by the size of the animals to be stopped and their ability to slip through them. It must also take into account any juveniles to prevent them from crossing the fencing on their own. For road and rail installations, the standard width of the meshes (wire spacing) is usually around 15cm, because the aim is to prevent the largest mammals from crossing.

When it is also necessary to avoid the penetration of smaller animals (hedgehogs, mustelids*etc.), additional arrangements are necessary. This will involve:

- either using progressive mesh fencing, i.e. tall, small meshed fencing with progressively wider horizontal wires - 5 to 15cm - on the bottom 1/2

or 1/3 of the total height. This type of fencing is recommended when there is no particular issue on the linear footprint;

- or backing onto the standard fencing (outer side), there is a second fence with a height (60cm to 1m) and mesh size to be defined according to the species to be stopped. It should usually be buried for greater efficiency (20 to 50cm) and possibly form an outward facing L when burrowing species are present (20cm vertical, 30cm horizontal folded outwards).

For some species, the top of the fence will have to form a 10 to 20cm flap with an outward 45° angle to prevent the species from climbing and crossing the barrier.

Without a specific configuration (e.g. very diffuse migration* of amphibians over a long distance), fencing is not recommended for amphibians and reptiles. Small walls (in metal, plastic or concrete) with flaps are to be preferred (see next chapter).

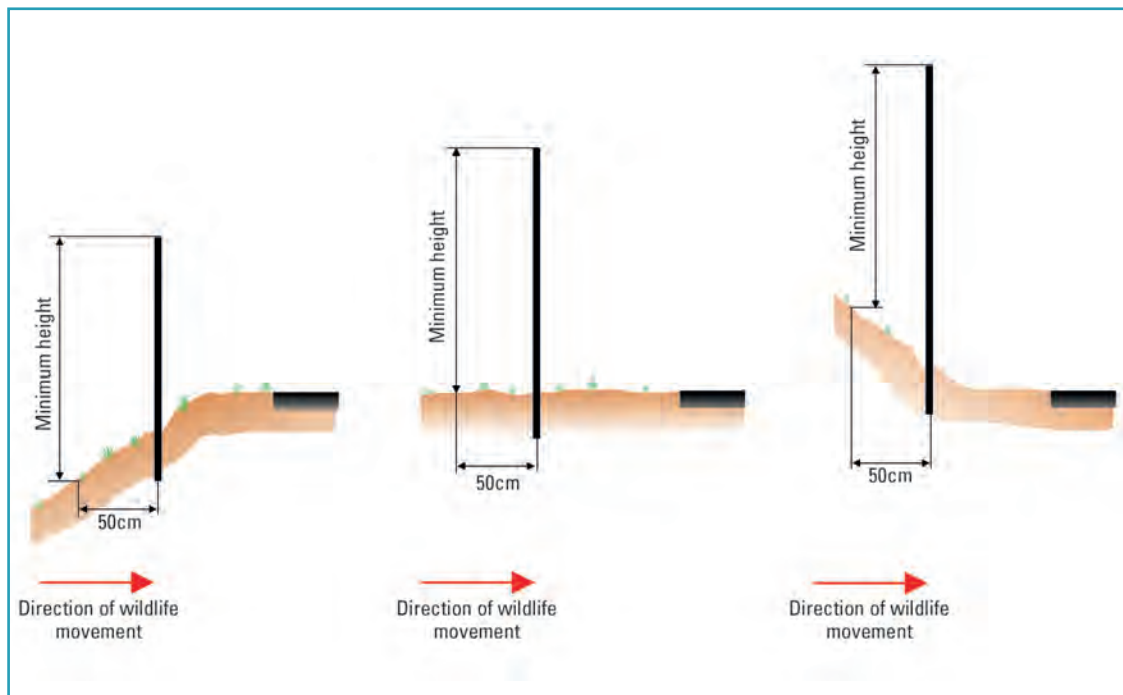

Determination of the minimum fence height according to the land configuration.

Source: according to the SNV 640693 standard of Union des professionnels suisses de la route.



Group of target species	Small fauna fencing					Large fauna fencing			Flying fauna	
	Amphibians, reptiles, hamsters, stoat	Rabbit, hare	Small mustelid* (mink, polecat, weasel, ermine, etc.) except stoat	Other small fauna: fox, badger, otter, beaver, hedgehog, etc.	Specific to felidae		Wild Boar	Roe deer		Deer Fallow deer
Height [above ground level]	Opt for smooth verges when there are high, localised issues	60cm (1m for hamster, stoat)	1m	1m	Wild cat	European lynx	1.4 to 1.6m	2m	2.1 to 2.4m	4m
Recommended fencing	Fence placed on large fauna fencing, welded wire mesh, with even-shaped mesh from top to bottom		Welded wire-mesh fence, with even-shaped mesh. Alone (possible for European mink, polecat) or placed on the large fauna fence	Welded wire-mesh fence, with even-shaped mesh. Alone (possible for otter, beaver, hedgehog) or in placed on the large fauna fence	Fencing consisting of knotted wire mesh, with even-shaped mesh		Knotted or welded wire-mesh fence, with even-shaped or progressive mesh.			Fencing consisting of knotted wire-mesh, with even-shaped mesh
Mesh size	H = w = 6.5mm	H = w = 1 to 3cm	H = w = 2 to 2.5cm	H = 5cm depending on the size of the species w = choice of 1 to 15cm (if welded wire mesh) otherwise < 5cm	H = w = 3cm	H = w = 3cm	Progressive mesh: w = 10 to 15 H = 5cm at the bottom to 10 x 20cm at the top Regular-shaped mesh: w = 15cm, H = 5cm	Progressive mesh: w = 10 to 15 H = 5cm at the bottom to 10 x 20cm at the top Regular-shaped mesh: w = 15cm, H = 15cm	Progressive mesh: w = 10 to 15 H = 5cm at the bottom to 10 x 20cm at the top Regular-shaped mesh: w = 15cm, H = 15cm	3 to 5cm
Accessory	10cm flap		/	/	20cm flap	50cm flap	/	/	Possibly 40 to 60cm flap	/
Planting	Buried 30cm	Buried 40cm in L shape (20cm + 20cm)	Buried 30cm	Buried 30 to 50cm for burrowing animals	Buried 30cm	Buried 30cm	Buried 30 to 50cm or placed on the ground and pinned with barbed wire Possibility of rigid welded wire-mesh at the foot of the fence	Buried 30 to 50cm or laid on the ground and pinned	Buried 30 to 50cm (especially in presence of wild boar) or laid on the ground and pinned	Placed on the ground (or buried or pinned if other groups)

Note: The different types of fences (A, B, C, D, E, F) are specified in the diagram on the next page.

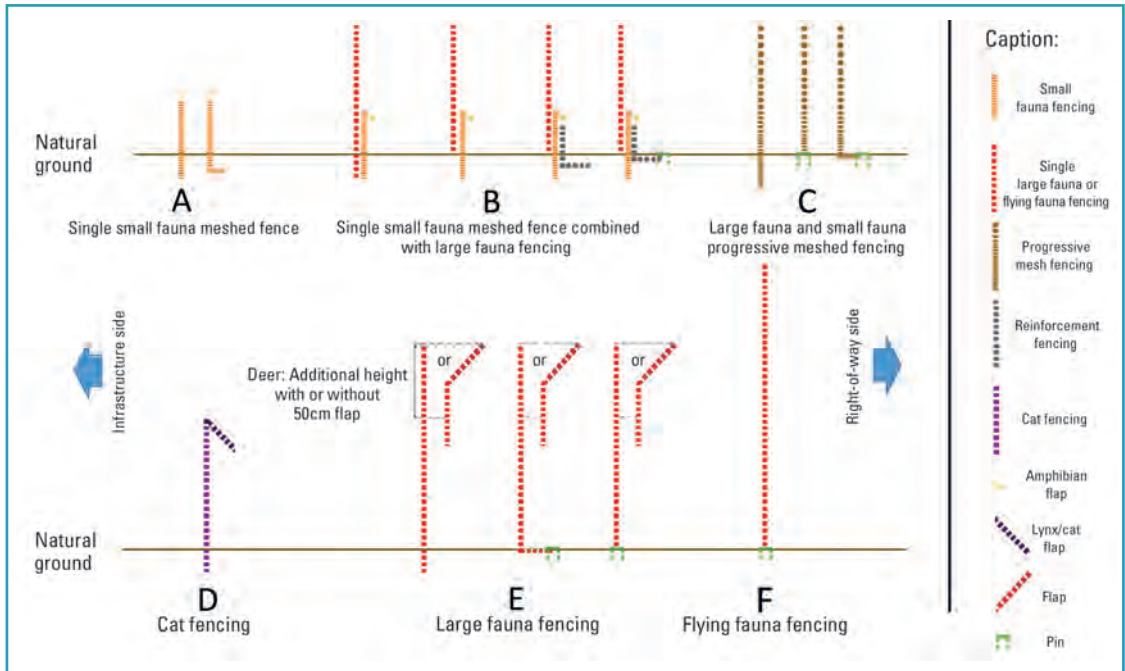

Diagram of all fence categories. Source: Cerema.



Example of a fine-mesh fence backed by a large fauna fence with progressive meshes. LGV Est. Source: Cerema.



Example of a large fauna fence with progressive meshes. RD 16 (CD57). Source: Cerema.



Example of a fence with a flap for lynx. B10 motorway, Germany. Source: Cerema.

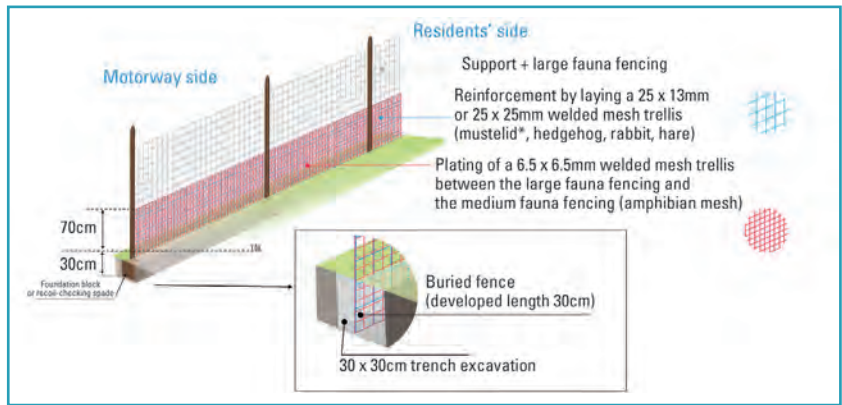

Example of fencing combining a large fauna fence, a welded wire mesh for small fauna and a fine welded wire mesh for amphibians. Source: Vinci Autoroutes.



Indicative cost (supply and installation, excluding the cost of openings, gates, etc.) of some categories of fences (information note *Clôtures routières et ferroviaires & faune sauvage*, Cerema, 2019):

- 1.8–2m standard large fauna fence: €35 to 50/lm excluding VAT;
- 1.4m small fauna fence (25 x 25 or 25 x 13mm welded mesh): €10 to 20/lm excluding VAT;
- batrachian fence (6.5 x 6.5mm mesh): €12 to 20 excluding VAT/lm.

Small fauna barriers

In some situations or for some small fauna species, it is preferable to replace fencing with non-open devices (see also chapter on amphibian devices). Most of them are.

- either walls made of concrete (1), polymer concrete (2) or metal angle sections (3) with a return on the ground (slightly sloping outwards to drain off water) several centimetres long (placed outside the infrastructure) designed to boost



1 Concrete edge Source: Maibach.



2 Polymer concrete edge.
 Source: Environment committee, municipality of Ahuy.



3 Metal edge crowned by a fauna fence. RD16 (CD57).
 Source: Cerema.

durability, help laying and maintenance and which form, on their base, a clear strip allowing the movement of species. These devices are for the most part composed of an assembly of pre-fabricated elements on a compacted, non-gelling bed 10 to 20cm thick. Some concrete barriers can also be cast on-site. These devices are around 40 to 60cm high (with a flap of at least 10cm), but in more specific situations, these borders may need to be taller (80cm to 100cm for otters, mink or snakes);



Double crash barriers as a fauna barrier

In some cases, the installation of a fence or another type of obstacle* is not possible (operating constraints in particular). It is then possible to prevent certain species from crossing the infrastructure with a double crash barrier (4).

For beavers, otters or European mink, this solution can give very good results, because it creates a visual obstacle*. It has the advantages of being durable over time and requires less maintenance than a fence. In the case of European mink, the ground seal must be applied so as not to leave a space greater than 2cm. Be careful to contact the road safety service, which in some cases is reluctant to allow them, considering that safety equipment should not be used for wildlife.



4 Double crash barrier acting as a fauna barrier.
 Source: Grège



Problem of double adherent concrete barriers and the risk of collisions with small fauna

To facilitate maintenance and limit interventions, metal guardrails installed on the infrastructure's central reservation (dual carriageway or more) are increasingly replaced by double adherent concrete barriers. While these devices, by their strength, offer advantages in terms of maintenance, they nevertheless constitute, with a height of 80cm, real barriers for small animals trying to cross the road. Stuck in the centre of the road, the small fauna then tends to follow the double concrete barrier without being able to find an escape route and usually ends up in wildlife vehicle collisions.

This situation leads to the recommendation to avoid the use of double adherent concrete barriers on central reservations and to prefer metal crash barriers to separate the traffic directions and thereby protect fauna.

If, however, the choice is made to install a double adherent concrete barrier, it is imperative, whatever the characteristics of the road (existing, new), to associate it with devices preventing access by small fauna to the roadway (specific fences, single adherent concrete barriers at the edge of roadways). In this respect, particular attention should be paid to old infrastructure, which, often, has never been fenced and, when newly equipped with double adherent concrete barriers, does not benefit from specific accompanying measures for wildlife.

Since anti-intrusion devices are never completely sealed, especially for smaller animals, it is also recommended that, when the double adherent concrete barriers are positioned in line with the central reservation, openings be created in these devices (e.g for draining: 30cm x 6-8cm) every 3m (minimum centre distance allowed) to give the smallest animals that have got into the coverage a chance to cross. Openings ("central reservation interruptions") protected by metal crash barriers can also be inserted at regular intervals, but the inclusion of such systems is regulated and complicates the device.

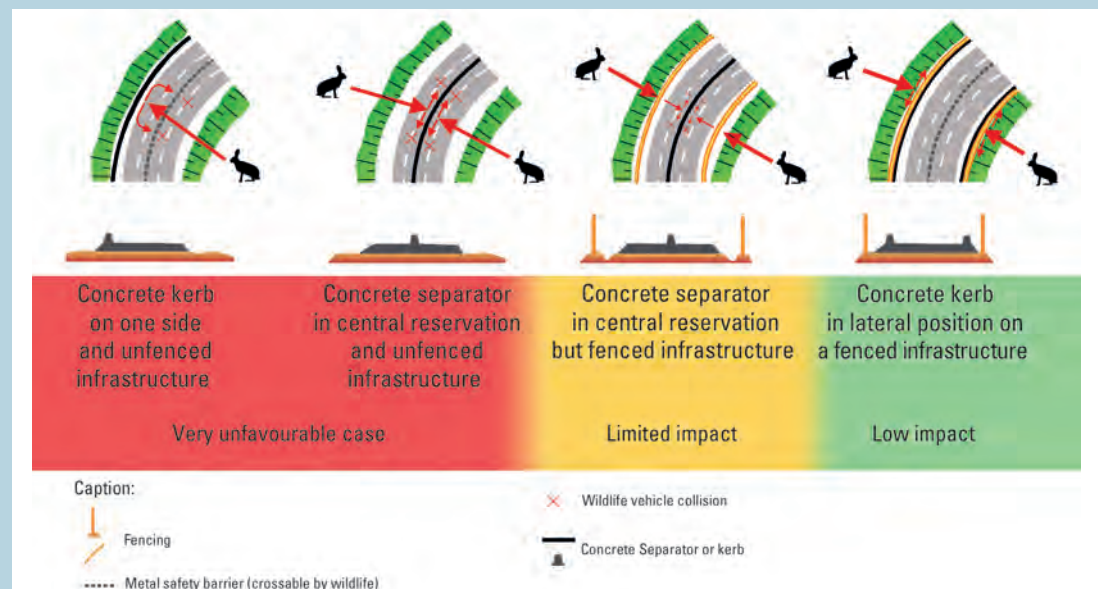

Differentiated impact on wildlife depending on the position of single adherent concrete barriers or double adherent concrete barriers. The barrier effect and the risk of wildlife vehicle collisions are not the same depending on the crash barrier position and presence or absence of fencing. Source: Jean Carsignol.



For metal barriers 40cm high with prior positioning of an installation bed €100 to 130 ex. VAT/lm.
Concrete walls cost around €150 to 200 ex. VAT/lm.

• or **plastic devices** for which there has been very little feedback. It seems that these devices are quite prone to crushing when they are self-supporting and generally do not allow use as support structures for the verges of the infrastructure or of the lower slope. However, if they back up fencing devices (e.g. plastic barrier + large fauna fence), they provide effective and impassable protection for species of small animals (amphibians, terrestrial insects, etc.).

HDPE (high-density polyethylene) plastic has the particular advantage of constituting a flexible barrier, which is therefore non-brittle (unlike hard plastics) and smooth. This last characteristic is particularly interesting for animals that are good climbers (e.g. lizards, turtles) and for which conventional fencing devices are not very effective (1). Backed by fences, these devices also have the advantage of letting individuals out of the coverage since they can always climb back over the fence (2);



High density polyethylene barrier attached to a fence. Source: Animex Fencing.



For plastic barriers (high-density polyethylene) attached to fences, the cost for 1,000lm is around €20 à 35 ex. VAT/lm (cost of the material supply alone is around €10/lm).



Use of HDPE barriers to treat a collision hotspot for otters and European mink

As part of the compensatory measures of the LGV SEA Tours-Bordeaux including upgrading* for European mink of 79 structures spread over 5 watersheds, HDPE barriers were implemented by COSEA in partnership with GREGE and local conservation associations, on three road crossings. More than 400 linear metres have been laid to provide wildlife vehicle collision protection for European mink and otters. These devices have shown a real advantage in terms of ease of installation, cost and, at this stage, no inconvenience has been observed, three years after installation.



Source: GREGE.

Étude comparative de l'efficacité des dispositifs de barrières plastiques et de clôtures mailles fines pour l'herpétofaune* lorsqu'elles sont utilisées comme mesures d'atténuation pour réduire la mortalité routière, John C. Milburn-Rodrigue et al., 2018.

To monitor the behaviour of the species towards the barriers, individuals of the species were placed in a closed enclosure of 25m. Half of the sides of this enclosure were equipped with fine meshed fencing and the other half with a solid plastic barrier (Animex). The study was conducted in Scale Natural Park, Ontario, Canada.



The study analysed the behaviour of 17 snakes (2 species), 20 frogs (2 species) and 14 tortoises (2 species).

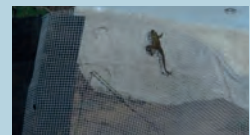

The results showed that:

Source : Animex.

- individuals of different species spent more time in the fenced area than in the area fitted with plastic barriers. This result tends to show that, faced with a plastic structure, individuals would be more likely to move and eventually reach fauna passages more quickly;
- all the study groups showed 40% more escape attempts by jumping or climbing over the fence than with the plastic barrier;
- while no species managed to cross the plastic barrier, all the species managed to cross the fence with the exception of one species of tortoise.

- devices made of recycled polymer concrete or recycled plastic are also proposed without any feedback on their reliability;



Edge in recycled plastic. B10 motorway, Germany.
Source: Cerema.



Curved edge in recycled plastic.
Source: ACO Group.

- wooden barriers, although aesthetically pleasing and economical, should be avoided in new projects, except in special cases, as they offer poor resistance and offer potential entry points to wildlife. However, they can be an appropriate

solution to insert protections on existing roads on which the coverage is very restricted. They also make it possible in certain situations to facilitate the implementation of escape exits (see next insert).



Barrier devices, when sufficiently robust, can act as devices for retaining the embankments over their whole height (about 50cm). This type of configuration allows the wildlife that has entered the infrastructure coverage to escape easily, while the reverse remains complicated (1).

With a device consisting of a small and large fauna fence, entry and exit are difficult (2).

These devices can be implemented in the context of new projects and for upgrading* (see below).

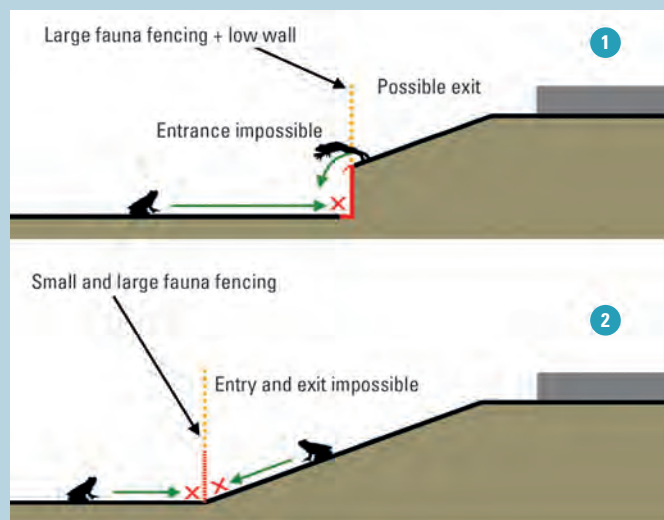

Source: Cerema.



Source: GREGE.

The example opposite shows the development designed by GREGE and COSEA during the implementation of nearly 8km of protection devices for European mink. Road sections were equipped with fences to prevent European mink and otters from accessing the roadway and being channelled towards the structures.

As entry points to the roadway could not be protected, escape routes were installed to allow the rapid exit of an animal that had managed to enter the roadway. These escape exits, located about ten metres in front of potential entry points, were made by filling the roadside of the fencing with draining materials, until only 20cm remained to be crossed. After two years of mortality monitoring, no corpses of any species were found on the protected sections.



Brittle rigid plastic border, not suitable for road use. Source: Cerema.



Green rights-of-way

The management of green rights-of-way in favour of biodiversity* and the establishment of genuine longitudinal rights-of-way is based on various recommendations.

- 1 Modelling the approaches to the roadway to provide a wildlife-friendly movement area**
 - Creation of a protective mound to separate/mask the movement of species from traffic.
 - Berm in heavy backfill to facilitate fauna movement.
- 2 Creating favourable vegetation management and adopting appropriate management**
 - Plantations or natural shrub regeneration to create fauna refuge and movement areas.
 - Ecological management.
- 3 Increasing wildlife hosting capacity by creating diversified habitats (swaths*, clusters of branches, hibernaculums*, etc.)**
- 4 Setting up a protective device (fences, barriers) preventing wildlife from accessing the infrastructure while allowing free access to the rights-of-way**
 - Position fences and barriers as close as possible to the infrastructure.
 - Ensure maximum seal of protective systems (bury fences, avoid entry points next to connections with structures, gates, etc.).
 - Choose devices adapted to the species present.
- 5 Providing escape routes so that wildlife can always get out of the infrastructure coverage**



HOW TO ENSURE THE LONG-TERM EFFICACY OF MEASURES: MAINTENANCE, MONITORING

FACT SHEETS

- 22 How to maintain fauna passages?
- 23 How should fauna passages be monitored?

How to maintain fauna passages?

The maintenance or management of all assets (road, engineering, natural, etc.) ensures good condition over time, while guaranteeing efficacy. It is therefore particularly important to maintain and manage developments in a sustainable way by checking, for example, that the structure is not diverted from its original purpose.

..... A few regulatory reminders

The obligation of maintenance has been laid down by the law in general (in particular by the French road design and administration code). Thus, the entity responsible for the road network (State, local authority, motorway manager) is responsible for the maintenance of the road network as well as any harmful consequences that may result from the lack of maintenance, including consequences on the safety of users. Case law has supplemented and clarified this general maintenance obligation laid down by statute law and recognises that the road network manager has an obligation to **maintain roads normally**.

Near forest areas sheltering large fauna and in zones where the passage of large animals is a common occurrence, this obligation to provide normal maintenance of the roads includes:

- at least, on each lane, marking danger zones;

Right from the public interest inquiry stage, the contracting authority should define to which entity it wishes to entrust the subsequent maintenance of the structures (maintenance vial local government control, association, or even a private company).

- on motorways only, the development of these zones in order to avoid the risk of wildlife vehicle collisions.

To date, general national regulation does not require the road network manager to erect fences as such along traffic lanes.

With regard to railway tracks, the manager must maintain the safety of traffic, its regularity, accessibility to emergency services and the conservation of railway infrastructure. Vegetation must be controlled on and around the track and its verges, all approaches and certain areas sensitive to the risk of fire.

For fauna passages, maintenance is an obligation under the French Environmental Code*, so that they can remain functional.

Maintenance of the structure and its immediate

Maintenance of fauna passages is the responsibility of the infrastructure manager. It requires specific precautions depending on their size and target species, but some considerations apply regardless of the structures. In order to ensure good practices in the long term, the implementation of a management plan for the structures can be appropriate.

Supervision of planted vegetation in the early years

In the first years, planted vegetation demands close supervision, particularly because of climatic conditions and the risk of invasive alien species. Once planted (November-March) and sown (September-March), a plant services fulfilment report must be filed within ten days.

Before definitively accepting the work, it is necessary to wait two growing seasons (about 21 months after the performance of the plant services).

During the first year (n+1), plants will be checked for successful rooting in the autumn (October) and, if necessary, will be replaced (November-December). In year n+2, a second report is to be made in the autumn (October) to confirm successful rooting, followed if necessary by the replacement of dead plants (November-December), then by the final acceptance²⁰.

Routine maintenance

Regular supervision is necessary to check that the environment of the structure does not undergo significant changes that could jeopardise its proper use by animals (clearing of adjacent

wooded plots, addition of stonework to the structure to facilitate its use by agricultural, forestry or private machinery – all-terrain or other equipment – , fencing at the entrances for agricultural or cynegetic* purposes, etc.).

The maintenance of the structures is the responsibility of the contracting authority which can however work with associative structures under contract to ensure optimal management for fauna and flora in particular on all fauna passages and dedicated passages (amphibians).

The use of educational or legal means upstream also makes it possible to limit corrective measures. Appropriate communication on the purpose of the structures to local residents (permanent information panels or regular educational events) can limit uncivil behaviour (see chapter "Ensuring good social acceptance", fact sheet no. 4).

■ On all fauna passages

The construction of some all fauna passages (in particular overpasses) are likely to facilitate long-term maintenance. The general objective is to minimise the need for vegetation maintenance on structures, in order to limit disturbances. Late annual mowing of grassy areas and occasional cropping of trees and shrubs are usually sufficient. On underpasses, the importance of interventions is generally more limited by the absence or scarcity of vegetation under the structure.

■ For small fauna passages

Small passages are particularly vulnerable and their effectiveness can be jeopardised by poor maintenance.

²⁰ Retours d'expérience des aménagements et des suivis faunistiques sur le réseau Vinci Autoroutes, June 2016.

Excessive development of vegetation at the entrances can make the structure inaccessible. Some conduits can be obstructed by obstacles (earth, branches, landslides, etc.); annual maintenance is therefore a minimum requirement. For this, it is sometimes necessary to use mechanical machines to clear the entrances and possibly high pressure jets to unclog the conduits. Intervention periods and techniques must also take into account the species potentially present and their ecology (reproduction, spawning, hibernation, etc.).

Dedicated passages may require more regular interventions. For example, for amphibians, it is recommended to intervene twice a year: before pre-nuptial migration* in February and in autumn.

Annual inspections of fauna passages must also be an opportunity to check the various additional developments (ponds, swaths*, anti-intrusion devices, etc.).

Fencing on the structure

Fencing is a complementary and indispensable element for the correct operation of passages, since it helps guide animals towards them. They must also be monitored regularly and in particular in line with connections to the structure, which are potential weak points. An annual inspection visit is therefore a way to identify possible faults and repair them.



Maintenance of the amphibian passage of the Grand Lemps National Reserve. Source: Cerema Centre Est - V. Billon.

Maintenance of green rights-of-way

Vegetation maintenance

Extensive management of green rights-of-way makes it possible to preserve biodiversity* while limiting maintenance costs. It must now be the rule, since it is compatible with safety obligations on all rights-of-way of infrastructure networks and, even more importantly, on crossings re-establishing ecological corridors. Maintenance depends on the extensive management methods used.

In the southern half of France, it will also be necessary to take into account legal clearing obligations related to the fight against forest fires. Any breaches observed must be corrected.

Fencing maintenance

The efficacy of a fence depends on its regular maintenance. This includes cleaning and repairing natural or deliberate damage. It increases the longevity of the device, but also avoids the liability of the road network manager in the event of an accident involving wildlife.

These breaches are most often related to:

- the destruction of the fence in a traffic accident;
- vegetation that grows on fences and ultimately makes it easier for fauna to climb over them;
- the collapse of fences due to the weight of vegetation or falling trees;

- damage caused by passing maintenance equipment or by farmers outside the road coverage;
- damage caused by wildlife (wild boar, badgers, etc.);

- the impact of floods and certain climatic episodes;
- forest fires;
- soil erosion in the case of restrictive installation contexts (slopes).



Amphibian fence brought down by the weight of the vegetation. Source: Cerema.



Fence damaged during a traffic accident. Source: Cerema.

Before brambles or branches weigh too heavily on the top of the fence and eventually lead to its collapse, the vegetation that borders the fences must be maintained. It is necessary to opt for mechanical maintenance at the foot of the fence:

- on the infrastructure side with a manual clearance of about 1m to 1.5m (manned clearing with a hand-held brushcutter) or 2m to 3m with an angle mower;
- on the outside only 50cm to 1m to avoid deterioration of the fence by trees (2m if maintenance is carried out using a machine) while ensuring some protection from large mammals.

Braces should be preferably placed in line with the fence to avoid complicating maintenance tasks.

Like points of connection to the structures, fittings connecting fencing to special equipment (gate, etc.)



The lack of maintenance of fencing on the outside of the road coverage prevents it from being kept in good condition. Source: Cerema.

require special monitoring, because they represent potential points of fragility.

In addition to the necessary repairs observed during routine maintenance of the roadway, an inspection of the fencing must be considered every year.

How should fauna passages be monitored?

Some general points, regulatory and methodological reminders

Regulatory texts define the general framework for monitoring the various measures:

L. 122-1-1 of the French Environmental Code^{*}: "The decision of the competent authority shall be supported in the light of the significant effects of the project on the environment. It specifies the requirements to be complied with by the contracting authority, as well as the measures and characteristics of the project, intended to avoid or reduce and, if possible, compensate for significant negative effects. It also specifies the **monitoring terms** of the project's impact on the environment or human health";

R. 122-5 II of the French Environmental Code: The impact assessment shall include the following elements [...] : 9° Where applicable, the **monitoring terms** of the proposed avoid, reduce and offset measures";

R. 122-13 II of the French Environmental Code: "[...] The **monitoring system** is proportionate to the nature and dimensions of the project, the extent of its anticipated impact on the environment or human health and the sensitivity of the areas concerned. "

In French **National Doctrine**²¹, the reference to monitoring arrangements is stated as follows: "On the basis of the contracting authority's proposals, the authorisation document shall lay down the essential and relevant arrangements for monitoring the implementation and effectiveness of the measures. Indicators must be developed by the contracting authority and validated by the decision-making authority to measure the state of implementation of the measures and their efficacy.

The contracting authority must set up a monitoring program in accordance with its obligations and proportionate to the impacts of the project."

The **Guidelines**²², on the other hand, address monitoring as outcome indicators: "The efficacy of each measure is evaluated by a monitoring program (in accordance with the procedures laid down in the authorisation act on the basis of the developer's proposals), i.e. by a series of data collections repeated over time which provide performance indicators. These follow-ups allow adaptive management focusing on the outcomes to be achieved".

It is also important to note that the contracting authority has an obligation to draft an appraisal (R. 122-13 II of the Environmental Code^{*}): "The monitoring of the implementation of the requirements, measures and characteristics of the project intended to avoid, reduce and offset the significant adverse effects of the project on the environment and human health referred to in I of Article L. 122-1-1 as well as the monitoring of their effects on the environment shall be the subject of one or more reviews carried out over a given period and according to a schedule determined by the competent authority, in order to verify the degree of effectiveness and the durability of these requirements, measures and characteristics. This or these appraisals are sent for information by the competent authority to take the authorisation decision, to the authorities mentioned in the V of Article L. 122-1 which have been consulted".

²¹ Relative to the *Avoid, reduce and offset impacts on the natural environment sequence* (March 2012).

²² National guidelines on the *Avoid, reduce and offset impacts on the natural environment sequence*, (October 2013).

Monitoring the efficacy of a measure

The rest of the chapter is dedicated to monitoring the effectiveness of measures in favour of wildlife movement. It itemises the different stages for adequate monitoring.

Describe in detail the measure associated with clearly worded or specific objectives

This description and the definition of the objectives of the measure are essential prerequisites when talking about efficacy. Indeed, without these details, only the notion of use ("is the passage used by wildlife?") may be assessed.

The construction of ecological transparency structures on transport infrastructure has been backed up by a very large number of studies on the use of these structures, most often mainly recording the number of animal crossings. Studies have shown that a wide range of species use the structures to cross the road to varying degrees. However, they do not sufficiently evaluate the efficacy of structures, that is to say, knowing whether these measures meet the specific objective of maintaining the flow of faunistic species in relation to given objectives.

As a first step, the objectives of the measure must therefore be specified. For example, for a given target species:

- the passage must allow daily movements between resting habitats and feeding sites;
- the passage must allow seasonal movement between resting sites and breeding sites;
- the passage must allow occasional movements to allow genetic mixing between subpopulations living in metapopulations*;
- more generally, at the project level, the overall permeability of the infrastructure must be capable of maintaining the population.

It is therefore important to do an initial status report in order to ensure the accuracy and relevance of downstream steps, in particular the definition of the impacts of the project and the monitoring of the measures. This monitoring only makes sense in relation to an initial situation that must therefore be characterised as precisely as possible, in relation to the potential impacts of the project.

Methodological recommendations for developing an initial statement can be found in fact sheet 10 of the ERC *Guidelines* (CGDD, 2013). This fact sheet includes important concepts such as the definition of study areas, periods suitable for field inventories, species descriptions and expected mappings.

Elaborating and implementing a monitoring program and protocol

The essentials:

- determining techniques specific to the habitat and/or species, to the group of species that are targeted and proportioned with respect to issues;
- collecting data at the right time, at the right frequency for a sufficient period of time;
- summarising and analysing data on the initial status, management actions conducted over the given period and the objective to be achieved.

The definition of **monitoring objectives** is an essential prerequisite for choosing the protocol (duration, species targeted, configuration of the structure, acquisition of specific data (number of crossings, schedules, individualisation, behaviour, available budget, etc.).

The choice of the **monitoring system** must be carefully studied according to the **monitoring objectives** and the features of the structure in line with the objectives of the measure.

Initially, the type of information to be collected is guided by the monitoring objective:

- evaluation of the use of a passage: need to collect maximum passage data (number of crossings and number of species using the structure). To characterise the use of structures and in particular to be able to compare structures with each other, their use must be expressed in terms of crossing rate, i.e. the number of crossings by a species per unit of time (or surface for low-mobility species: performance rate per species);
- evaluation of fauna behaviour with respect to the structure: in order to assess this behaviour, systems (photo/video trap) are directed towards the element studied (structure entrance, fencing);
- evaluation of the efficacy of a passage on maintaining populations.

This point is not addressed here because it tends to fall within the field of research (population study). At this level, the study of the efficacy of a measure requires a much more advanced level of investigation, in that it requires a spatial and temporal sampling plan adapted to a number of species which needs to be determined. A BACI (Before, After, Control, Impact) type study where data is collected before and after the reduction measures, both on the structures, but also on several reference sites (similar to the site where the structures are located), can be envisaged, in order to check the role played by the structures. These studies must also be carried out over a fairly long period of time, because there is an effect of habituation or improvement of the quality of the passage (planting) and its surroundings (repair).

The monitoring objective may focus on a particular species. In this case, it is necessary to choose the optimal equipment to detect the species. It is however recommended to choose methods capable of tracking several species.

Secondly, the technical characteristics of the structure to be monitored influence the choice of

the device. Two major criteria are used to outline the restrictions conditioning the choice of device:

- effective width of the passage: the narrower the structure, the easier it is to monitor. The increase in its width implies for example increasing the number of camera traps (maximum fauna identification interval less than 15m at night), enlargement of the footprint trap or impossibility of covering the whole width of the passage with a vibration trap;
- underpass or overpass: the positioning of the monitoring equipment in an underpass makes it possible to overcome many meteorological biases (precipitation, wind, sun, significant thermal amplitude, etc.). On the contrary, on an overpass (open-air), the footprint trap, the vibration trap and, to a lesser extent, the camera trap all prove to be less effective.

It is important to choose and precisely define monitoring methods and equipment before starting any evaluations, for each typology of structure studied, by first classifying the structures according to size, typology and the species or groups of species for which they were built. Then monitoring should be set up in the same way for each class of structure and each species or group of species targeted, without changing the protocol established during the evaluation until the end of the monitoring period (except in special cases, for example, taking into account feedback, local factors (vandalism), etc.). Strict compliance with these conditions allows several statistically reliable and usable comparisons of structures over a defined period of time. The results and conclusions resulting from statistical analyses are all the more robust and relevant.

The following table lists the advantages and disadvantages encountered with each monitoring method. The details of these methods can be found in the book published by Vinci Autoroutes and the LPO: *Retour d'expérience des aménagements et des suivis faunistiques sur le réseau Vinci Autoroutes*, 2016.



Wild cats caught in the camera trap on a structure on the A89 motorway. Source: FDC 63/ASF Vinci Autoroutes network.



Deer caught by a camera trap. Source: FDC 17/ASF Vinci Autoroutes network.

	Advantages	Disadvantages
Camera trap – still and movement – (in infra-red mode)	<ul style="list-style-type: none"> • Significant autonomy • Time-stamped data • Individualisation is possible in some very special cases • Behaviour study is possible 	<ul style="list-style-type: none"> • Does not detect cold-blooded animals • Can be intrusive for medium-sized wildlife (fox, weasel, etc.) • Detection rate never evaluated, lowering with the reduction of species size • Risk of theft
Camera trap (in trigger mode at standardised intervals)	<ul style="list-style-type: none"> • Automatically samples • Also triggered in infra-red • Adapted to slow amphibian movements (1 shot/15 s) 	<ul style="list-style-type: none"> • Reduced autonomy • Not suitable for fast movements • Very large number of photos to check
Footprint trap	<ul style="list-style-type: none"> • The trap can be adapted in size • Minimal intrusion • Passage count almost exhaustive if the methodology is rigorous 	<ul style="list-style-type: none"> • Variable interpretation (humidity, substrate) of footprints (underestimated use) • Data is not time-stamped • No individualisation • Observer bias • Frequent checks required
Photoelectric barrier camera trap	<ul style="list-style-type: none"> • Average autonomy • Time-stamped data • Almost exhaustive passage count 	<ul style="list-style-type: none"> • Risk of theft • More costly • More costly installation
Vibration camera trap	<ul style="list-style-type: none"> • Significant autonomy • Time-stamped data • Individualisation is possible in some very special cases • Detects cold-blooded animals • Also triggered in infra-red and movement 	<ul style="list-style-type: none"> • Small dimension of the mat (about 1m²) • Intrusive for medium-sized wildlife (fox, weasel, etc.) • Device not suitable for outdoor use • Currently being developed to increase its sensitivity
Presence sensors (fur, faeces traps with genetic identification)	<ul style="list-style-type: none"> • Easier sampling for micromammals* • Adapted to assess specific assets 	<ul style="list-style-type: none"> • No counting
Capture (mark-recapture)	<ul style="list-style-type: none"> • Identification and even individualisation • Interpretation of movement during recaptures 	<ul style="list-style-type: none"> • Very intrusive • No behavioural data • Observation pressure limited in time
Direct observation	<ul style="list-style-type: none"> • Behavioural data 	<ul style="list-style-type: none"> • Can sometimes be intrusive • Observer bias • Time-consuming • Observation pressure limited in time
Ultrasound recorder (chiroptera*)	<ul style="list-style-type: none"> • Significant autonomy • Identification is possible 	<ul style="list-style-type: none"> • Unknown flight paths with a single recorder
Thermal camera (chiroptera*)	<ul style="list-style-type: none"> • Known flight paths 	<ul style="list-style-type: none"> • Observation pressure limited in time (requires an operator) • Identification is complicated
Trajectorygraphy (chiroptera*)	<ul style="list-style-type: none"> • Known flight paths • Identification is possible 	<ul style="list-style-type: none"> • Still rarely used

Advantages and disadvantages of the different tracking methods used by Vinci Autoroutes. Source: Vinci Autoroutes modified by GREGE.

Entering **the collected data** is essential and is often very time-consuming. It therefore needs to be optimised from the outset according to the monitoring objectives. In addition to the parameters used to characterise the structures (dimensions, types of facilities, etc.) and monitoring (observation pressure, type of equipment, etc.), the input of data (corresponding to the passage of an animal) requires a minimum level of information: date, time, species, number of individuals, crossing, behaviour, etc.

It is impossible to predict precisely the time of entry, as the number of passages of animals is

very variable. For reference, data input (with the aforementioned minimum level of information) of 400 to 500 fauna passages requires about 3 hours' work (for a person familiar with this type of work).

Finally, the **monitoring protocol or program** must be based on **monitoring methods** adapted to the different taxa involved, standardised, as far as possible, in order to be reproducible over time.

In the field of road ecology, the most widely used monitoring methods are summarised in the table below.

Taxa	Monitoring methods used
Mammals	Camera trap, footprint trap, fur trap, ink trap, search for signs of presence (footprints, faeces, spraints*, etc.), thermal photography by drone (size identification of large mammal populations)
Micromammals*	Capture-Mark-Recapture (CMR)
Chiroptera*	Detection (Batbox), automatic ultrasonic recorder (Annabat, SM2), net capture, thermal or infra-red camera
Amphibians	Nocturnal scouting (net fishing), Ortmann's trap, brood counts, temporary barrier and collection in buckets (movements), environmental DNA (pond)
Reptiles	Visual survey (transects), thermoregulation plate
Entomofauna*	Targeted survey, transects (e.g. butterflies), environmental DNA (odonates in ponds)
Fish	Nocturnal survey, electric fishing, environmental DNA
Birds	Targeted survey, listening points (count points)
Flora	Stock count on targeted species, phytosociological survey, analysis of vegetation structure, etc.

Wildlife monitoring methods used in road ecology (modified according to Vinci Autoroutes, June 2016).



Monitoring by camera traps on structures on the Vinci Autoroutes network

Vinci Autoroutes monitored 81 structures, including 66 dedicated fauna structures and 15 non-dedicated fauna structures. 76 structures were tracked by infra-red detection camera traps to collect more than 25,000 passage data items between 18/02/2011 and 29/04/2015. The volume of this database has produced calculations of average passages per year, per type of structure (see illustration 1) and per species (see illustration 2).

41 species were photographed, including 29 species of mammals, 4 species of amphibians, 4 species of reptiles and 4 species of nidifugous birds (leaving the nest immediately after hatching).

Analysis of the results showed that on the structures monitored:

- all fauna overpasses allowed the largest number of passages for all species put together;
- small dry pipes (ø 0.8m to 1.20m, between 31 and 75m long) are also frequently used both in terms of the number of different species (33) and number of crossings;
- up to 80m long, no significant difference in use by fauna was observed, depending on the length of the crossing of small fauna or developed waterway structures. However, beyond 80m, the structures are less frequented with fewer user species (mainly burrowing species);
- small fauna passages located over a watercourse, a privileged ecological corridor, are used by a larger number of species than in structures not associated with a watercourse (28 against 20) and with a much higher average presence (401 crossings/year/structure against 226 crossings/year/structure);
- for large mammals, it is observed that deer exclusively passed over all fauna overpasses (eco-bridge*) and, without being exclusive, wild boar and roe deer used this same passage category for the most part.

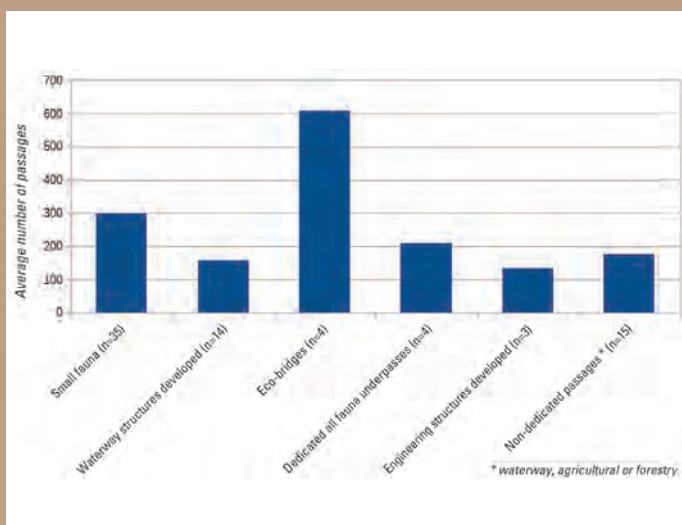

1 Average number of passages (small, medium and large fauna) detected per year and per type of structure. Source: Vinci Autoroutes.

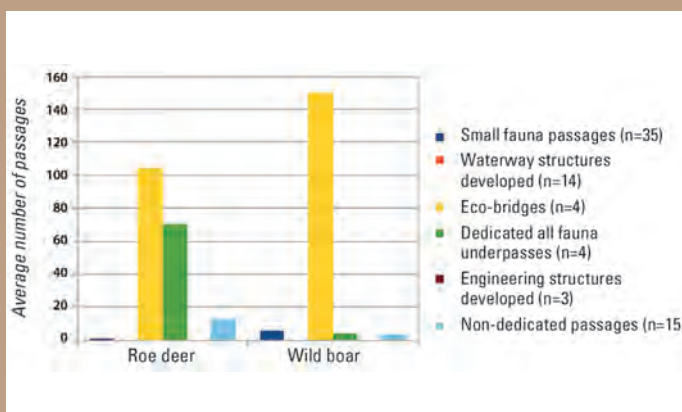

2 Average number of passages for large mammals detailed per type of structure. Source: Vinci Autoroutes.

Glossary

- **All fauna passage:** a large structure allowing the crossing of a linear transport infrastructure (road/motorway, railway track, canal) by large and small fauna and which, more generally, makes it possible to restore the ecological network interrupted by the passage of the infrastructure. They can be partially or totally developed to facilitate crossing by wildlife. Passages are called "overpasses" or "underpasses" depending on whether they pass above or below the infrastructure. The term "dedicated fauna passage" will be used for structures whose sole function is to ensure the safe passage of wildlife through the LTI and "mixed fauna passage" for structures which also have a hydraulic, agricultural, forestry and/or pedestrian function.
- **Arase :** niveau supérieur d'un ouvrage de maçonnerie, généralement mis bien à plat, servant de base pour la suite de la construction (source : Wikipedia).
- **Avoid-reduce-offset:** the so-called "ARO" sequence aimed at reconciling economic development and environmental issues, forming the common thread for integrating the environment into planning documents and land use projects. For the latter, the aim is to avoid any damage to natural environments and associated services; failing this, to reduce them; and, lastly, to offset them (source: OFB).
- **Beetle:** from the Carabidae family, large-sized terrestrial insects.
- **Bench (in a waterway structure):** space reserved or developed at the foot of lateral walls inside a waterway structure to allow dry-standing passage of this structure by terrestrial fauna. This space, connected to the banks of the watercourse located on either side of the structure, can be made of natural or artificial materials.
- **Berm:** platform created in the middle of a large slope to increase its stability and make its maintenance easier (source: Wikipedia).
- **Biodiversity:** term used to describe the number, variety and variability of living beings, usually considered as three types of organisation: individuals and populations (genetic heritage); species and taxa; ecosystems and landscapes. The concept of biodiversity is defined by the Convention on Biological Diversity as "variability among living organisms from all sources including, inter alia, terrestrial, marine and other aquatic ecosystems and the ecological complexes of which they are part; this includes diversity within species, between species and of ecosystems" (art. 2). Biodiversity is not only a question of numbers, but also of difference (composition, beta diversity), (source: INPN).
- **Black grid:** the black grid is the set of biodiversity reservoirs and ecological corridors characterised by darkness and used by nocturnal species (source: OFB). A variation of the green and blue grid* in the temporal dimension (day/night alternation) intended to solve the problem of habitat fragmentation caused by artificial night light.
- **Box culvert** in civil engineering, designates a short span structure in the form of a reinforced concrete frame. It is based on a pad if the ground is rocky or on a reinforced concrete foundation raft * if it is not.
- **Burrowing (for an animal):** the action of digging or scraping the earth.
- **Chiroptera:** order name assigned to bats (source: Larousse).

- **Code de l'environnement (Environmental code):** it groups together French legal texts relating to environmental law. This code has seven chapters: *Common provisions, Physical environments, Natural areas, Fauna and flora, Prevention of pollution, risks and nuisances, Provisions applicable in New Caledonia, French Polynesia, Wallis and Futuna, in the French southern and Antarctic territories and Mayotte, Protection of the environment in Antarctica*. To access the code: <https://www.legifrance.gouv.fr/affichCode.do?cidTexte=LEGITEXT000006074220> (source : Wikipedia).
- **Coleoptera:** order of insects with rigid elytrons protecting their wings. This is the order that has the largest number of described species (nearly 387,000 in 2015) including beetles, ladybirds, stag beetles, chafers, weevils, ground beetles (source: Wikipedia).
- **Corbelled bench:** bench consisting of decking (platform a few centimetres thick) suspended and fixed on the side walls inside a hydraulic structure, connecting the banks on each side of the structure and allowing dry-standing passage of terrestrial fauna. This type of bench is generally used in the context of the upgrading of existing structures whose dimensions (hydraulic capacity) do not allow the installation of a bench on the bed of the watercourse (which would lead to a reduction in the width of the bed in the structure, thereby calling into question hydraulic flow capacities, and to an acceleration of the flow speed making the structure difficult for fish to pass through).
- **Crown:** part of a tree consisting of a structured set of branches located at the top of the trunk (from the master branches to the secondary branches) (source: Wikipedia).
- **Cynegetic:** relating to hunting (source: Larousse).
- **Dicotyledons:** plants whose seedling resulting from the germination of a seed presents two leaves, called cotyledons or seed leaves, before emerging into the open air (source: Wikipedia).
- **Differentiated management:** method of managing green spaces consisting in adapting the management of spaces (in terms of mowing and pruning frequency) depending on their location, features and uses. (source: MOOC Herbes Folles Tela Botanica).
- **Eco-bridge:** a large overpass (> 20m) built above a linear transport infrastructure (road/motorway, railway track, canal) and specifically designed to restore ecological transparency interrupted by the passage of the infrastructure. It is a structure supporting a layer of soil that is enough to grow plants. It thereby maintains maximum connectivity with the habitats located on either side of the structure and allows crossing by many animal species.
- **Edaphic:** relating to the soil (source: Larousse). In ecology, edaphic factors are related to the nature of the soil (pH, humidity, etc.).
- **Entomofauna (or entomological fauna):** part of the fauna consisting of insects, which includes apterygotes, characterised by the absence of wings, and pterygotes. Entomofauna refers to the entire population of insects present in an environment (source: Wikipedia).
- **Entomological:** which relates to entomology, which relates to articulated animals, especially insects (source: Centre national de ressources textuelles et lexicales).
- **Environment:** in ecology, it is specific, characteristic and clearly delineated (source: MNHN).
- **Eutrophic:** medium rich in over-abundant nutrients, which cannot be totally used by the "normal" population of a biotope (source: according to Universalis).
- **Exceptional all fauna passage:** very large fauna passage (> 50m) designed to reproduce habitats (or protect them if the passages are tunnels or viaducts) and if possible the structure of the initially destroyed (or crossed) landscape, most often by a linear transport infrastructure (road/motorway, railway tracks, canal). This reconstruction makes it possible to restore (or maintain) maximum connectivity for a maximum number of fauna and flora species.

- **Fauna crossing:** structure built or developed to allow the crossing of a linear transport infrastructure (road/motorway, railway track, canal) by wildlife. There are large "all fauna passages" that allow the crossing of a large number of wildlife species of large and small fauna and "small fauna passages" more specifically reserved for the smallest animals.
- **Foundation raft:** thick masonry or concrete slab constituting the foundation of a structure (source: Larousse).
- **Gabion:** in civil engineering, a metal body filled with materials and used to protect the banks of a watercourse or to build retaining walls (sources: Larousse and Wikipedia).
- **Giro-grinding:** mowing and shredding technique used on all grassy plants and shrubs. This technique, usually requiring a tractor to tow the machinery, leaves a pile of plant debris on the ground.
- **Glacis :** rampe en pente douce.
- **Gliridae:** family of medium-sized rodents called dormice, garden dormice, forest dormice, shrew, or even mice (source: Wikipedia).
- **Green and blue grid:** terrestrial and aquatic ecological network identified by regional ecological coherence schemes as well as by the planning documents of the State, local authorities and their groupings. It contributes to the improvement of the conservation status of natural habitats and species and to the healthy ecological status of water bodies. It applies to the entire national territory with the exception of the marine environment (source: CDR TVB).
- **Habitat (of species):** 1. A species habitat corresponds to the living environment of the species (breeding area, feeding area, resting area, etc.). It may include several natural habitats. 2. A natural habitat is understood to mean a whole indissociable from: a fauna, with species having all or part of their various living activities in the area in question; a vegetation (grass, shrub, tree); a localised compartment (climatic conditions, soil and parental material and their physico-chemical properties). A habitat is not limited to vegetation alone. But vegetation, by its integrative character (synthesising the conditions of the environment and the way the system operates), is considered to be a good indicator and can be used to determine habitat (source: Rameau et al., 1998) (source: INPN).
- **Headroom:** free space between the lowest level (ground, waterline) and the deck of a structure.
- **Heather (*Calluna vulgaris*):** a shrub with a lignified base, bearing many tight, erect and more or less sinuous branches.
- **Hermit beetle (*Osmoderma eremita*):** species of beetle in the Scarabaeidae family, the Cetoniinae (ketone) subfamily. It is a declining, endangered and protected species (source: Wikipedia).
- **Herpetofauna:** part of the fauna consisting of amphibians and reptiles (source: Wikipedia).
- **Hibernaculum:** refuge, shelter or part of a burrow used for the hibernation of an animal (source: Wikipedia).
- **Higher plants:** plants multiplying by seeds.
- **Home range:** an area where an animal ordinarily lives and which is sufficient to meet its primary needs. The home range can apply to an average individual, a typical couple or possibly a population within a metapopulation, for all or part of its/ their life cycle (the home range must therefore be defined for a given time interval (season, year, or lifetime) (source: Wikipedia).
- **Leporidae:** family of lagomorphic mammals including hares and rabbits (source: Wikipedia).
- **Life cycle (or development cycle):** period during which a succession of phases making up the complete life of a living organism takes place. These phases include birth (germination in plants), growth, feeding, reproduction, and finally death (source: Wikipedia).

- **Light-fugitive:** which flees, avoids light (source: Centre national de ressources textuelles et lexicales).
- **Messicole:** Messicole plants are meadow plants. They are annual plants, such as poppies or corn flowers, most often dependent on cereal crops and practices related to these crops (source: Conservatoires botaniques nationaux).
- **Metapopulation:** set of populations of the same species, separated by geography, between which there is more or less abundant and frequent exchanges (gene flow) (source: Futura science).
- **Micromammals:** small mammals (carnivores, rodents, insectivores, etc.) grouped in this particular category because of their small size (source: Wikipedia).
- **Migration (of species):** seasonal movement of certain animals between a breeding area and an inter-nuptial zone (wintering, hibernation, magnification, sexual maturation, etc.) (source: PNR Cotentin).
- **Mustelids:** family of carnivorous, usually nocturnal, mammals, with a narrow and elongated body, low on their legs. They include weasels, badgers, ermine, otters, ferrets, mink and martens (source: Centre national de ressources textuelles et lexicales).
- **Natura 2000:** European ecological network of natural sites (ZPS and ZSC) designated under the "Habitats" Directive and designed to conserve species and habitats of community value within an overall sustainable development framework taking into account socio-economic practices (source: INPN).
- **Natural reserve:** an area where the conservation of fauna, flora, soil, water, mineral and fossil deposits and, in general, the natural environment is of particular importance. This area should be protected from any artificial intervention likely to degrade it. In France, there are national nature reserves (RNN), nature reserves of the regional collectivity of Corsica (RNC) and regional nature reserves (RNR). Their management is entrusted to nature protection associations including conservatories of natural areas, public institutions and local authorities (source: INPN).
- **Obstacle (to the movement of species):** an obstacle to the ecological network is a human element or part of the humanised territory that has the consequence of fragmenting habitats and limiting habitats or making them impossible to cross by certain species. It can be occasional, linear or on the surface and of various types (infrastructure, dam, degraded environments, simplified landscapes, artificial soil or land worked by humans, light, chemical or noise pollution, etc.) (source: Légifrance or ONTVB).
- **Oligotrophic:** refers to an environment poor in nutrients. Term used to describe plants capable of surviving in very poor environments (source: Larousse).
- **Orthophotography:** aerial or satellite images of the earth's surface that are geometrically rectified and radiometrically equalised. These images in the form of sheets covering an area of the Earth can be georeferenced in any coordinate system (source: Wikipedia).
- **Orthoptera:** an insect with four wings and two rear wings, with straight ribs, that fan out under elytrons, such as crickets, grasshoppers (source: Centre national de ressources textuelles et lexicales).
- **Paquet vert autoroutier:** contract signed between the French State and motorway concessionary operators. Developed in two rounds of negotiations in 2008 and 2009, following the Grenelle Environment Forum, this plan provided for a set of environmental motorway works in return for an extension of the concession period (1 year). Several objectives were set: the reduction of noise pollution, the protection of water resources and biodiversity, the upgrading of motorway rest areas and the reduction of CO₂ emissions (source: French Senate).

- **Phytosanitary (products):** chemical used to care for, protect, help the growth of plants or to prevent diseases (source: Wikipedia).
- **Plant protection products:** preparations designed to protect plants and crops. They fall under the pesticide category, which also include biocides and antiparasitics for human and veterinary use (source: Agence nationale de sécurité sanitaire de l'alimentation, de l'environnement et du travail).
- **Public inquiry:** when local authorities implement developments, structures or works which, through their very nature, are liable to damage the environment, such operations are subject to a public inquiry. The purpose of this inquiry is to provide information and ensure public participation, as well as to take into account the interests of third parties and to collect the opinion of the public on these operations, in order to give the public body, in this case the local authority, the necessary information (source: State portal for local authorities, <https://www.collectivites-locales.gouv.fr/enquetes-publiques>).
- **QMNA [equivalent in English to MMAMD (Mean Monthly Annual Minimum Discharge)]:** in hydrology, the value of the monthly low flow reached by a watercourse for a given year. Calculated for different durations: 2 years, 5 years, etc., it makes it possible to statistically assess the smallest flow of a watercourse over a given period. The most common QMNA is QMNA5 (source: Wikipedia).
- **Resilience:** the ability of a system (ecological or otherwise) to return to its previous operating state after disruption (source: MNHN).
- **Riverine vegetation:** all the wooded or bushy formations present on the banks of a watercourse (source: Wikipedia).
- **Rosette:** arrangement of numerous and fanned out leaves, arranged in a circle, close together, all ending in an underground stem or rhizome or aerial branches (source: Centre national de ressources textuelles et lexicales).
- **Rutting:** mating cry of deer or fallow deer (source: Universalis).
- **Sapling:** young tree that begins to show its first shoots.
- **Saproxyllic (species):** carrying out all or part of its life cycle in decaying wood, or the products of this decomposition. It is associated with both living and dead trees (source: Wikipedia).
- **Small fauna passage:** small sized structures mainly reserved for the passage of small animals. They can have a specific vocation (batrachian tunnel, canopy passage, etc.), but are more generally small recovery structures (box culverts*, ducts) which, without too much difficulty, offer a minimum level of transparency for a large proportion of animals ranging from the size of a fox to the smallest species of microfauna.
- **Species:** a monophyletic group of individuals that recognise themselves as sexual partners and are capable of producing fertile offspring. Basic grouping of the classification of living beings. For current animals, the species can be defined as the set of inter-fertile individuals, that is to say capable of reproducing among themselves and of producing offspring. A specimen is referred to by its genus name and then its species name (source: MNHN).
- **Spraints:** in zoology, otters' faeces.
- **Stone pitching:** cladding of dry stone or masonry, intended to reinforce an embankment, the banks of a river, the walls of a canal, etc. (source: Centre national de ressources textuelles et lexicales).
- **Sub-grid:** on a given territory, brings together all the spaces constituted by the same type of environment (wooded, humid, etc.) and the network constituted by these more or less connected spaces. It is composed of biodiversity reservoirs, ecological corridors and, possibly, other spaces that help to form the sub-grid for the corresponding type of environment.

- **Swath:** a cluster of branches, stumps or stones forming a continuous strip that creates a continuity of hiding places or microhabitats for wildlife.
- **Terrace:** called a "Restanque" in Provence, consisting of dry stone walls supporting terraced farming (source: Larousse).
- **Trophic:** which relates to the nutrition of an individual, of a living tissue, e.g. trophic needs (source: Larousse).
- **Upgrading:** regulatory upgrading in terms of nature and environmental protection, for example of a road, motorway or railway route, when development work is planned on an existing route (e.g. widening of the emergency stop strip, creation of a slip road, etc.).
- **Urodele:** order of batrachians characterised by an elongated body, a developed tail and four limbs (salamanders, newts) (source: Centre national de ressources textuelles et lexicales).

List of abbreviations

APA	Avant-projet autoroutier - Preliminary motorway project
CEIN	Continuités écologiques d'importance nationale - Ecological networks of national importance
CMR	Capture-Mark-Recapture
CNPN	Conseil national de la protection de la nature - National Conservation Council
CNRS	Centre national de la recherche scientifique - National scientific research centre
CPIE	Centre permanent d'initiatives pour l'environnement - Permanent centre for environmental initiatives
CSRPN	Conseil scientifique régional du patrimoine naturel - Regional natural heritage scientific council
DBA	(séparateur ou glissière) double en béton adhérent
DiRIF	Direction interdépartementale des routes Île-de-France - Greater Paris interdepartmental roads directorate
DIRO	Direction interdépartementale des routes Ouest - West interdepartmental roads directorate
DREAL	Direction régionale de l'Environnement, de l'Aménagement et du Logement - Regional Department for the environment, urban planning and housing (or DEAL in French overseas territories). Decentralised services of the French State, under the joint supervision of the Ministry of Ecological Transition and the Ministry of Territorial Cohesion (source: Wikipedia).
DUP	Déclaration d'utilité publique - Declaration of public utility
ENS	Espace naturel sensible- Sensitive natural area
GBA	Glissière en béton adhérent
GIS	Geographical information system. System designed to collect, store, process, analyse, manage and present all types of spatial and geographic data (source: Wikipedia)
GREGE	Groupe de recherche et d'étude pour la gestion de l'environnement - Research and study group for environmental management
GRP	Glass reinforced polyester
HDPE	High density polyethylene. Opaque, impact-resistant plastic, impermeable to water, certain chemicals, gas and flavourings
IMPCF	Institut méditerranéen du patrimoine cynégétique et faunistique - Mediterranean institute of hunting and wildlife
INRAE	Institut national de recherche pour l'agriculture et l'environnement - National research Institute for agriculture and the environment
IOTA	Installations, ouvrages, travaux et activités - Installations, structures, works and activities
IPBES	<i>Intergovernmental science-policy platform on biodiversity and ecosystem services</i>
ITPC	Interruption de terre-plein central
ITTECOP	Infrastructures de transports terrestres, écosystèmes et paysages - Land transport infrastructure, ecosystems and landscapes
IUCN	International Union for Conservation of Nature
MCT	Ministère de la Cohésion des territoires - Ministry of territorial cohesion

MNHN	Muséum national d'Histoire naturelle - Natural history museum
MTE	Ministère de la Transition écologique - Ministry of ecological transition
OAP	Orientation d'aménagement et de programmation - Planning and programming guideline
OFB	Office français de la biodiversité - French biodiversity office
OGE	Office de génie écologique - Ecological engineering office
ONCFS	Office national de la chasse et de la faune sauvage - National office of hunting and wildlife
ONF	Office national des forêts - National forestry office
ONTVB	Orientations nationales trame verte et bleue - National green and blue grid guidelines
ORE	Obligation réelle environnementale - Real environmental obligation
PAH	Polycyclic aromatic hydrocarbon
PLU(i)	Plan local d'urbanisme (intercommunal) - Local urban development plan. Main urban planning document at municipal (PLU) or intercommunal (PLUi) level. It is a general development project of the municipality or municipalities, targeting sustainable development, within the framework of the planning and sustainable development project (PADD), while respecting urban planning, housing and urban transport policies (source: Wikipedia)
PLUM	Plan local d'urbanisme (intercommunal) - Local metropolitan urban development plan
PRAD	Pont à poutres précontraintes par adhérence
SCoT	Schéma de cohérence territoriale - Regional integrated development plan. Tool for the design and implementation of inter-municipal strategic planning, at the level of a living or urban area, as part of a sustainable development and development project (PADD) (source: Ministry of Territorial Cohesion and Relations with Local Authorities)
SEA	Sud Europe atlantique - Atlantic Southern Europe
SRADDET	Schéma régional d'aménagement, de développement durable et d'égalité des territoires - Regional plan for management, sustainable development and territorial equality Regional planning scheme that merges several existing sectoral documents or schemes: Regional Land Use Planning and Sustainable Development Scheme (SRADDT), Regional Waste Prevention and Management Plan (PRPGD), Regional Intermodality Scheme (SRI), Regional Air Energy Climate Scheme (SRCAE) and SRCE. SRADDET - which replaces SRADDT, created in 1995 and amended in 1999 - was established by the NOTRe Act in the context of the establishment of the new Regions (in 2016) (source: Wikipedia)
SRCE	Schéma régional de cohérence écologique - Regional ecological coherence scheme. Spatial planning scheme (prior to SRADDET) and the protection of certain natural resources (biodiversity, ecological network, natural habitats) aimed at achieving the healthy ecological status of water imposed by the Water Framework Directive. It is a framework document developed in each region, updated and monitored jointly by the Region (Regional Council) and the State (Regional Prefect) in association with a Green and Blue regional committee (source: TVB Nouvelle Aquitaine). In particular, it presents and analyses regional issues relating to the conservation and restoration of the ecological network
TVB	Trame verte et bleue - Green and blue grid
ZNIEFF	Zone naturelle d'intérêt écologique, faunistique et floristique - Natural zone of ecological, flora and fauna value

Bibliography

- AFE, UMS Patriat/MNHN, Centre de ressources TVB, *Pollution lumineuse et Biodiversité : état des connaissances et retours d'expérience. Actes de la journée 19 décembre 2017*, Paris, 29 p.
- Alves B., *Effect of conventional bridges on deer-vehicle accidents. Faculty of natural resources and agricultural sciences, Department of ecology, Grimsö wildlife research station*, 2012, 28 p.
- Ament R. et al., *Wildlife Crossings: The new norm for transportation planning*, 2015, p. 45-47.
- Andis A. Z., Huijser M. P. & Broberg L., *Performance of arch-style road crossing structures from relative movement rates of large mammals. Frontiers in ecology and evolution*, 2017, 13 p.
- ASF Réseau Vinci Autoroutes, *Recueil des dossiers d'information du programme environnement du plan de relance autoroutier*, 2015.
- Ascensão F. and Mira A., *Factors affecting culvert use by vertebrates along two stretches of road in southern Portugal. Ecological Research*, 2007, p. 57-66.
- Association Hommes et Territoires, *Gestion des dépendances routières et bordures de champs à l'échelle de la région Centre dans le cadre du Grenelle de l'environnement et de La Trame Verte et Bleue*, 2011, 79 p.
- ATEN, Escota & Cabinet X-AEQUO, *Éco-Restanques pour écopont à haute fonctionnalité écologique*, 2016, p. 1-15.
- Audie-Liebert J., Biaunier J., Breteau J.-F. et al., *Rapport SRCE et requalification des infrastructures - Rapport technique*, Cerema, 2019, 30 p.
- Babińska-Werka J., Krauze-Gryz D., Wasilewski M. & Jasińska K., *Effectiveness of an acoustic wildlife warning device using natural calls to reduce the risk of train collisions with animals. Transportation research part D: Transport and Environment*, 2015, p. 6-14.
- Backs, J. A. J., Nychka J. A. & St. Clair C. C., *Warning systems triggered by trains could reduce collisions with wildlife. ecological engineering. Elsevier B.V*, 2017, p. 563-569.
- Backs, J. A. J., Nychka J. A. & St. Clair C. C., *Warning signals triggered by trains increase escape time for wildlife. Edited by van der Ree, R. TransportEcology.info*, Accessed at: <https://transportecology.info/research/warning-signals-trains>, 2020, 7 p.
- Baigas P. E. et al., *Using environmental features to model highway crossing behavior of Canada Lynx in the southern Rocky mountains. landscape and urban planning. Elsevier B.V*, 2017, p. 200-213.
- Baillie D., *Installation d'un passage protégé « écuroduc » à poulie unique*, 2012, 33 p.
- Bain T. K., Cook D. G. & Girman D. J., *Evaluating the effects of abiotic and biotic factors on movement through wildlife crossing tunnels during migration of the California tiger salamander, ambystoma californiense. Herpetological Conservation and Biology*, 2017, p. 192-201.
- Ballók Z., Náhlik A. & Tari T., *Effects of building a highway and wildlife crossings in a red deer (Cervus Elaphus) habitat in Hungary. Acta silvatica et Lignaria hungarica*, 2010. p. 67-74.
- Barrientos R. et al., *Railway ecology vs. road ecology: similarities and differences. European journal of wildlife research*, 2019, p. 0-9.

- Barrientos R., Plaza M., *Road-kill hot spots can change over the time, variables explaining them do not*. Colloque IENE, 2016, 27 p.
- Baxter-Gilbert J. H., Riley J. L., *Mitigating reptile road mortality: fence failures compromise ecopassage effectiveness*. *PLoS ONE*, 2015, p. 1-15.
- Baxter-Gilbert J. H. et al., *Road mortality potentially responsible for billions of pollinating insect deaths annually*. *Journal of insect conservation*, Springer international publishing, 2015, p. 1029-1035.
- Beben D., *Crossings construction as a method of animal conservation*. *Transportation research Procedia*. Elsevier B.V., 2016, p. 474-483.
- Beben D., *Crossings for Animals - an effective method of wild fauna conservation*. *Journal of environmental engineering and landscape management*, 2012, p. 86-96.
- Bédard Y. et al., *Conception et suivi des passages à petite faune sous la route 175 dans la réserve faunique des Laurentides*. *Le Naturaliste Canadien*, 2012, p. 66-71.
- Benhamou S., *Le domaine vital des mammifères terrestres*, *Rev. Ecol. (Terre Vie)*, vol.53., 1998, <http://hdl.handle.net/2042/54904>
- Benítez-López A., Alkemade R. & Verweij P. A., *The impacts of roads and other infrastructure on mammal and bird populations: a meta-analysis*. *Biological Conservation*. Elsevier Ltd., 2010, p. 1307-1316.
- Benten A., Annighöfer P. & Vor T., *Wildlife warning reflectors' potential to mitigate wildlife-vehicle collisions-a review on the evaluation methods*. *Frontiers in ecology and evolution*, 2018, p. 1-12.
- Benten A. et al., *Wildlife warning reflectors do not mitigate wildlife-vehicle collisions on roads*. *Accident analysis and prevention*. Elsevier, 2018, p. 64-73.
- Bergès L., Roche P., Avon C., *Corridors écologiques et conservation de la biodiversité, intérêts et limites pour la mise en place de la Trame verte et bleue*, Sciences Eaux & Territoires, 2010, p. 34-39.
- Bhardwaj M., Olsson M. & Seiler A., *Ungulate use of non-wildlife underpasses*. *Journal of environmental management*. Elsevier Ltd, 2020, 6 p.
- Bil M., et al., *An evaluation of odor repellent effectiveness in prevention of wildlife-vehicle collisions*. *Journal of environmental management*, 2018, p. 209-214.
- Billon L., *Programmes d'étude et récoltes de données sur les collisions Faune/véhicules en France métropolitaine*, Service du patrimoine naturel, Muséum national d'histoire naturelle, Paris, 2014, 29 p.
- Billon L., Sordello R. & Touroult J., *Protocole de recensement des collisions entre la faune sauvage et les véhicules : proposition d'un socle commun*. Service du patrimoine naturel, Muséum national d'histoire naturelle, Paris, 2015, 18 p.
- Billon L. et al., *Méthode d'analyse des données issues du protocole de recensement des collisions faune/véhicule pour la détection de zones à risque*, Service du patrimoine naturel, Muséum national d'histoire naturelle, Paris, 2015, 30 p.
- Bissonette J. A. & Adair W., *Restoring habitat permeability to roaded landscapes with isometrically-scaled wildlife crossings*. *Biological Conservation*, 2008, p. 482-488.
- Bissonette J. A., *Evaluation of the use and effectiveness of wildlife crossings NCHRP 25-27*, 2007, 287 p.
- Bond A. R. & Jones D. N., *Temporal trends in use of fauna-friendly underpasses and overpasses*. *Wildlife research*, 2008, p. 103-112.
- Borda-de-Água L. et al., *Railway ecology*, 2017, p. 1-320.

- Brandjes G. J. et al., *Do animals use wildlife crossings in the Netherlands?*, Colloque IENE, 2016, 1 p.
- Breudaud J.-F., *Requalification environnementale du réseau DIRO. Analyse de l'efficacité de réflecteurs de dissuasion de la grande faune*, 2018, 5 p.
- Breudaud J.-F. et al., *Permettre à la faune de franchir les infrastructures linéaires de transport, Exemples de requalifications d'infrastructures*, Cerema, Collection Expériences et pratiques, 2019, 80 p.
- Brodziewska J., *Wildlife tunnels and fauna bridges in Poland : past, present and futur 1997-2013*, *Dermatology online journal*, 2013, 14 p.
- Brunen B. & Jaeger J.A.G., *What attributes are relevant for drainage culverts to serve as efficient road crossing structures for mammals?* *Transport Ecology.info*, Accessed at: <https://transportecology.info/research/attributes-for-water-culverts-as-crossing-structures>, 2021.
- Buton C., Nowak N., Lecigne S., *Analyse réglementaire et technique : Cadre juridique des traversées de voies routières par des animaux sauvages*, 2013, 35 p.
- Burkholder E. N. et al., *To jump or not to jump: mule deer and white-tailed deer fence crossing decisions*, *Wildlife society bulletin*, 2018, p. 420-429.
- Burt W. H., *Territoriality and home range concepts as applied to mammals*. *Journal of Mammalogy*, 1943, p. 346-352.
- Buton C., Maurice S. & Laforet L., *L'éco-restanque, la technique des andains écologiques adaptée à des écoponts méditerranéens*, 2014, 13 p.
- Cain A. T. et al., *Effects of a highway and mitigation projects on bobcats in southern Texas*. *Biological conservation*, 2003, p. 189-197.
- Canadien Naturaliste, *Numéro spécial colloque sur l'écologie routière et l'adaptation aux changements climatiques : de la recherche aux actions concrètes*, 2019, 138 p.
- Caldwell M. R., Klip J. M. K., *Wildlife Interactions within Highway Underpasses*. *The Journal of Wildlife Management*, 2019, p. 227-236.
- Carr T., Dacanay R., *Wildlife crossings: rethinking road design to improve safety and reconnect habitat*, 2003, 103 p.
- Carsignol J., Pineau C. & Bielsa S., *Clôtures routières et faune. Critères de choix et recommandations d'implantation*, 2008, 22 p.
- Carsignol J., *Des passages à gibier à la trame verte et bleue : 50 ans d'évolution pour atténuer la fragmentation des milieux naturels en France*, *Le Naturaliste Canadien*, 2012, p. 76-82.
- Carsignol J. and Tekielak G., *Clôtures routières et ferroviaires & faune sauvage. Critères de choix et recommandations d'implantation*, 2019, 32 p.
- Caryl A., Beroud T., *Les échappatoires à sangliers SANGLI-PASS®*, Cabinet Ex-Aequo, 2013, p. 12.
- Cavaillès J., Guinard E. & Vermeersch P., *Infrastructures linéaires de transport et reptiles. Application à trois espèces protégées à enjeux forts. Note d'information Environnement - Santé - Risque*, SETRA, 2015, 21 p.
- Cerema, *Les dispositifs anti-accès motorisé. Comment contrôler l'accès aux aménagements cyclables*, Cerema, Collection Références, 2016, 14 p.
- Cerema, *La gestion différenciée des dépendances vertes - Phase 1 et 2*, Cerema, Collection Expérience et pratiques, 2018, 42 p.
- Chisholm M. & Cooper D., *Wildlife passage engineering design guidelines*, 2010, 249 p.
- Claus K., *Building an ecoduct in an agricultural environment - A challenge for people and animals*, Colloque IENE, 2016, 16 p.
- Clauzel C., Mimet A., Foltête J.C., *How to attenuate the barrier effect of linear infrastructures?*

- A method for prioritizing existing crossings to improve wildlife regional connectivity*, Colloque IENE, 2016, 2 p.
- Clevenger A. P., Sawaya M. A., Landguth E. L., *Trans-canada highway Yoho National park: mitigation and opportunities assessment for wildlife*, 2017, p. 1-187.
- Clevenger A. P., Chruszcz B. & Gunson K., *Highway mitigation fencing reduces wildlife-vehicle collisions*. *Wildlife Society Bulletin*, 2001, p. 646-653.
- Clevenger A. P., Waltho N., *Factors influencing the effectiveness of wildlife underpasses in Banff National Park*. *Conservation Biology*, 2016, p. 47-56.
- Clevenger A. P., *Conservation value of wildlife crossings: measures of performance and research directions*, *Gaia*, 2005, p. 124-129.
- Clevenger A. P., Chruszcz B. & Gunson K., *Drainage culverts as habitat linkages and factors affecting passage by mammals*, *Journal of Applied Ecology*, 2001, p. 1340-1349.
- Clevenger A. P., Huijser M. P., *Handbook for design and evaluation of wildlife crossing structures in North America*, 211 p.
- Clevenger A. P., and Kociolek A. V., *Highway median impacts on wildlife movement and mortality - State of the practice survey and gap analysis*, *Security*, 2006, 129 p.
- Clevenger A. P. & Leblond M., *Leçons tirées de l'étude des passages fauniques enjambant une autoroute dans le Parc National de Banff*, *Le Naturaliste Canadien*, 2012, p. 35-41.
- Clevenger A. P., Waltho N., *Performance indices to identify attributes of highway crossing structures facilitating movement of large mammals*, *Biological Conservation*, 2005, p. 453-464.
- Corlatti L., Hackländer K. & Frey-Roos F., *Ability of wildlife overpasses to provide connectivity and prevent genetic isolation*, *Conservation Biology*, 2009, p. 548-56.
- Cramer P., Hamlin R., *Evaluation of wildlife crossing structures on US Highway 93*, *Transportation*, 2003, 4 p.
- Cramer P., *Culvert bridge and fencing recommendations for big game 2 wildlife crossings in western United States based on Utah data*, *Transportation research board 93rd Annual Meeting*. January 12-16, Washington, 2014.
- Cramer P., *Determining wildlife use of wildlife crossing structures under different scenarios*. *Utah Department of Transportation Research Division*, 2012, 181 p.
- Craveiro J. et al., *Impact of culvert flooding on carnivore crossings*. *Journal of environmental management*, 2019, p. 878-885.
- Crenn G., *Ouvrages hydrauliques routiers - Analyse des passages à petite faune*, Conseil Général du Morbihan, 2011, 12 p.
- Croyal A. S., *Réduction des collisions sur les routes départementales : passages petite faune et détecteurs*. *Journée d'échanges techniques « Continuités écologiques et collisions avec la faune : des données aux solutions »*, Paris, Grande Arche La Défense, 2 juillet 2019, 2019, 13 p.
- D'Amico M. et al., *General versus specific surveys: estimating the suitability of different road-crossing structures for small mammals*. *Journal of wildlife management*, 2015, p. 854-860.
- D'Angelo G. J. et al., *Evaluation of wildlife warning reflectors for altering white-tailed deer behavior along roadways*, *Wildlife society bulletin*, p. 1175-1183.
- Davis M. J., *Wildlife warning reflectors and white canvas reduce deer-vehicle collisions and risky road-crossing behavior*, *Wildlife society bulletin*, 2018.

- Département de l'Isère, *Écosphère, Hydrosphère, Couloirs de vie - Projet de restauration et de préservation des corridors biologiques du Grésivaudan, Synthèse d'évaluation scientifique et technique*, 2015, 64 p.
- Dodd C. K., Barichivich W. J. & Smith L. L., *Effectiveness of a barrier wall and culverts in reducing wildlife mortality on a heavily traveled highway in Florida. Biological conservation*, 2004, p. 619-631.
- Dodd N. L., et al., *Wildlife-vehicle collision mitigation for safer wildlife movement across highways: state route 260*, 2012, 134 p.
- Dorey J., *Les routes et bords de routes : barrières ou corridors écologiques ? Mémoire bibliographique*, Université de Rennes, 2010, 26 p.
- Dorsey B., Olsson M. & Rew L. J., *Ecological effects of railways on wildlife. Handbook of road ecology*, 2015, p. 219-227.
- Ecotec, *Bases pour la directive « planification et construction de passages à faune à travers des voies de communication »*, 2011, 28 p.
- Edelhoff H. et al., *Effects of landscape fragmentation on genetic diversity and population structure of red deer (Cervus elaphus) in Northern Germany, Mammalian biology*, 2016.
- Eco-Kare International, *Effectiveness of wildlife mitigation measures for turtles on Highway 69 from 2015 to 2016. A report for public dissemination submitted to the Ontario Ministry of Transportation, North Bay, Ontario, Canada*, 2015, 86 p.
- Fairbank E. R., *Use and effectiveness of wildlife crossing structures with sections of wildlife fencing in Western Montana*, 2011, 27 p.
- Ford A. T., Clevenger A. P., *Factors affecting the permeability of road mitigation measures to the movement of small mammals. Canadian journal of zoology*, 2019, p. 379-384.
- Ford A. T., Clevenger A. P. & Bennett A., *Comparison of methods of monitoring wildlife crossing-structures on highways. Journal of wildlife management*, 2009, p. 1213-1222.
- Ford A. T., Clevenger A. P., Huijser M. P. & Dibb A., *Planning and prioritization strategies for phased highway mitigation using wildlife-vehicle collision data. Wildlife biology*, 2011, p. 253-265.
- Foster M. L., and Humphrey S. R., *Use of highway underpasses by florida panthers and other wildlife. Wildlife society bulletin*, 1995, p. 95-100.
- Fournier P. et al., *New high-speed rail-road sea between tours and bordeaux. Evaluation of use and effectiveness underpasses implemented to maintain optimal permeability for semi aquatic mammals, International conférence IENE*, 2016.
- François D., Le Féon V., *Abeilles sauvages et dépendances vertes routières. Pourquoi et comment développer la capacité d'accueil des dépendances vertes routières en faveur des abeilles sauvages*, 2017, 120 p.
- Fuhrmann M., Tauchert J., *Annahme von kleintier-durchlässen – Einfluss der laufsohlenbeschaffenheit und des kleinklimas auf die erfolgreiche durchquerung*, 2010, 149 p.
- Gagnon J. W. et al., *Cost-effective approach to reducing collisions with elk by fencing between existing highway structures. Human-wildlife interactions*, 2015, p. 248-64.
- Georgii B. et al., *Nutzung von grünbrücken und anderen querungshilfen durch säugetiere. gesamtbericht zum forschungs- und entwicklungsvorhaben*, 2006, 109 p.
- Georgii B. et al., *Use of wildlife passages by invertebrate and vertebrate species. Introduction 2 Study Area, <http://www.Oeko-Log.Com/>*, 2011, p. 1-27.

- Gigleux M., De Billy V., *Petits ouvrages hydrauliques et continuités écologiques - Cas de la faune piscicole. Note d'information du Sétra - Série Économie et Environnement Conception*, Setra, 2012, p. 1-25.
- Gilhooly P. S. et al., *Wildlife mortality on roads and railways following highway mitigation. Ecosphere*, 2019, 16 p.
- Girardet X., Conruyt-Rogeeon G. & Foltête J. C., *Does regional landscape connectivity influence the location of roe deer roadkill hotspots? European journal of wildlife research*, 2015, p. 731-742.
- Glenside Ecological Services Limited, *Turtle road mortality mitigation project 2014-2016*, 2016, p. 88.
- Glista, David J. et al., *A review of mitigation measures for reducing wildlife mortality on roadways. Landscape and urban planning*, 2009, p. 1-7.
- Glista D. J., DeVault T. L. & DeWoody J. A., *A review of mitigation measures for reducing wildlife mortality on roadways, Landscape and urban planning*, 2009, p. 1-7.
- Gloyne C. C., and Clevenger A. P., *Cougar Puma concolor use of wildlife crossing structures on the trans-canada highway in Banff National Park, Alberta. Wildlife biology*, 2001, p. 117-124.
- Gordon K. M., *Mule deer use of underpasses in Western and Southeastern Wyoming*, 2003, p. 309-318.
- Grandmaison D., *Crossing structures and fencing to reduce wildlife mortality*, 2015, 1 p.
- Guarnieri M., *Impacts of human presence at wildlife crossing structures*, 2019, 1 p.
- Guinard E., Pineau C., *Les mustélidés semi-aquatiques et les infrastructures routières et ferroviaires. Loutré et vison d'Europe*, 2007, 13 p.
- Gunson K., Seburn D., Kintsch J. & Crowley J., *Best management practices for mitigating the effects of roads on amphibian and reptile species at risk in Ontario*, 2016, 112 p.
- Hlavá V. et al., *Wildlife and traffic in the Carpathians. guidelines how to minimize impact of transport infrastructure development on nature in the Carpathian countries*, 2019, 226 p.
- Huijser M. P., Paul K. J. S., *Wildlife-vehicle collision and crossing mitigation measures: A Literature Review for Parks Canada, Kootenay National Park*, 2008, 119 p.
- Huijser M. P. et al., *Effectiveness of short sections of wildlife fencing and crossing structures along highways in reducing wildlife-vehicle collisions and providing safe crossing opportunities for large mammals. Biological conservation*, 2016, p. 61-68.
- Huijser M. P. et al., *Animal vehicle crash mitigation using advanced technology, phase I: review, design and implementation, Oregon department of transportation research unit*, 2006, 292 p.
- Huijser M. P. et al., *Best practices manual : wild-life-vehicle collision reduction study: report to U.S. congress*, 2008, 204 p.
- IENTE, *International Conference on Ecology and Transportation Life for a Greener Transport Infrastructure September 16-19, 2014 Malmö, Sweden - Programme & abstracts*, 2014, 178 p.
- Jacobson S. L. et al., *A behavior-based framework for assessing barrier effects to wildlife from vehicle traffic volume. Ecosphere*, 2016, 15 p.
- Jaeger J. et al., *Monitoring the effectiveness of wildlife passages for medium-sized and small mammals along HW 175*, 2012, p. 1-27.
- Jaeger J. et al., *Landscape fragmentation in Europe. European environment agency*, 2011, 87 p.
- Jakes A. F. et al., *A fence runs through it: a call for greater attention to the influence of fences on wildlife and ecosystems. Biological conservation*, 2018, p. 310-318.

- Jeffrey W., Raymond E. & Norris L., *Use of video surveillance to assess wildlife behavior and use of wildlife underpasses in Arizona*, 2005, p. 534-544.
- Jones D. N. & Pickvance J., *Forest birds use vegetated fauna overpass to cross multi-lane road*. *Oecologia Australis*, 2013, 10 p.
- Jumeau J., *Facteurs à l'origine de la distribution d'une communauté amphibien dans les bassins d'eaux pluviales : Une étude de cas dans la plaine agricole du Bas-Rhin, France*, 2020, 20 p.
- Jumeau J. et al., *Factors driving the distribution of an amphibian community in stormwater ponds: a study case in the agricultural plain of Bas-Rhin, France*. *European journal of wildlife research*, 2020, 20 p.
- Kachamakova M. N., Zlatanova D. P., *Use of non-specialised structures as wildlife passages, Iyulin motorway, Bulgaria*, IENE Conference, 2016, 1 p.
- Karlson M., Seiler A., Mörtberg U., *The effect of fauna passages and landscape characteristics on barrier mitigation success*. *Ecological engineering*, 2017, p. 211-20.
- Kelm J. et al., *How often does a strictly arboreal mammal voluntarily cross roads New insights into the behaviour of the hazel dormouse in roadside habitats*, *Folia zoologica*, 2015, p. 342-348.
- Kintsch J. A. & Cramer P., *Permeability of existing structures for terrestrial wildlife : a passage assessment system*. *Transportation research*, 2011, 188 p.
- Kintsch J. A. & Cramer P., *A Standardized Framework for using camera traps to monitor wildlife crossing structures*, 2015, 1 p.
- Kociolek A. V. et al., *Wildlife crossings. national geographic*, 2019, 5 p.
- Krauze-Gryz D. et al., *Temporal pattern of wildlife-train collisions in Poland*. *Journal of wildlife management*, 2017, p. 1513-1519.
- Kusak J. et al., *The permeability of highway in Gorski Kotar (Croatia) for large mammals*. *European journal of wildlife research*, 2009, p. 7-21.
- Kušta T. et al., *Effectiveness and costs of odor repellents in wildlife-vehicle collisions: a case study in Central Bohemia, Czech Republic*. *Transportation research Part D : Transport and environment*, 2015, p. 1-5.
- Lapoint S. D., Forest B. R. & Kays R., *Animals crossing the Northway : are existing culverts useful?*, 2014, p. 11-17.
- LBM, *Grünbrücken rheinland-pfalz - 10 jahre monitoring - eine erfolgsgeschichte für die wiedervernetzung von wildtierkorridoren bei straßenbauvorhaben in rheinland-pfalz*, 2011, 80 p.
- Lesbarrères D. & Fahrig L., *Measures to reduce population fragmentation by roads : what has worked and how do we know?* *Trends in ecology and evolution*, 2012, p. 374-380.
- Lister N. M., Brocki M. & Ament R., *Integrated adaptive design for wildlife movement under climate change*. *Frontiers in ecology and the environment*, 2015, p. 493-502.
- Little S. J., Harcourt R. G. & Clevenger A. P., *Do wildlife passages act as prey-traps?* *Biol. Conserv.*, 2002, p. 135-145.
- Markle C. E. et al., *The true cost of partial fencing: evaluating strategies to reduce reptile road mortality*. *Wildlife society bulletin*, 2017, p. 342-350.
- Martinig A. R. & Bélanger-Smith K., *Factors influencing the discovery and use of wildlife passages for small fauna*. *Journal of applied ecology*, 2016, p. 825-836.
- Massachusetts Department of Transportation, *Design of bridges and culverts for wildlife passage at freshwater streams*, 2010, 294 p.
- Mata C. et al., *Effectiveness of wildlife crossing structures and adapted culverts in a highway in Northwest Spain*, 1999, p. 4-6.

- Mata C. et al., *Are motorway wildlife passages worth building ? Vertebrate use of road-crossing structures on a spanish motorway. Journal of environmental management*, 2008, p. 407-415.
- Mata C. et al., *Complementary use by vertebrates of crossing structures along a fenced spanish motorway. Biological conservation*, 2005, p. 397-405.
- Mata C. et al., *Seasonal changes in wildlife use of motorway crossing structures and their implication for monitoring programmes. Transportation research. Part D : Transport and environment*, 2009, p. 447-452.
- McGregor M. E., Wilson S. K. & Jones D. N., *Vegetated fauna overpass enhances habitat connectivity for forest dwelling herpetofauna. Global ecology and conservation*, 2015, p. 221-231.
- McInturff A. et al., *Fence ecology: frameworks for understanding the ecological effects of fences, BioScience*, 2020, p. 971-985.
- Meese R. J. et al., *Wildlife crossings assessment & mitigation manual., Landscape*, 2007, p. 1-87.
- Mimet A., Clauzel C. & Foltête J. C., *Locating wildlife crossings for multispecies connectivity across linear infrastructures. Landscape Ecology*, 2016, p. 1955-1973.
- Ministère de la Transition écologique et solidaire - Direction générale des infrastructures de transport et de la mer, *Instruction technique relative aux modalités d'élaboration des opérations d'investissement et de gestion sur le réseau routier national*, 2018, 202 p.
- Ministère de l'Écologie du Développement durable et de l'Énergie, Commissariat général au développement durable, Direction de l'eau et de la biodiversité, *Lignes directrices nationales sur la séquence Éviter, Réduire et Compenser les impacts sur les milieux naturels*, Collection Références, 2013, 230 p.
- Ministry of transportation - Province of Ontario, *Environmental guide for mitigating road impacts to wildlife*, 2017, 108 p.
- Ministry of Agriculture, Food and the Environment, *Technical prescriptions for wildlife crossing and fence design (second edition, revised and expanded). Documents for the mitigation of habitat fragmentation caused by transport infrastructure, Number 1*, 2016, 124 p.
- Ministry of Transport Construction and Regional Development of the Slovak Republic, *Migration structures for wildlife part 1: project engineering, construction, operation, maintenance and repair of ecoducts*, 2011, p. 1-40.
- Morand, A. et Carsignol J., *Amphibiens et dispositifs de franchissement des infrastructures de transport terrestre. Cerema, Collection Connaissances*, 2019, p. 1-58.
- Mysłajek R. W. et al., *Utilisation of a wide underpass by mammals on an expressway in the Western Carpathians, s Poland, Folia zoologica*, 2016, p. 225-232.
- Mysłajek R. W. et al., *Mammal use of wildlife crossing structures along a new motorway in an area recently recolonized by wolves, European journal of wildlife research*, 2020, 14 p.
- Natural England, *Green bridges - A literature review. natural england commissioned report NECR181*, 2015, 51 p.
- Natureparif, *Les passages à faune en bois*, 2009, 13 p.
- Nezval V. & Bil M., *Spatial analysis of wildlife-train collisions on the Czech rail network. Applied geography*, 2020, 7 p.
- Ng S. J. et al., *Use of highway undercrossings by wildlife in Southern california. Biological conservation*, 2004, p. 499-507.
- Niehaus A. C., and Wilson R. S., *Integrating conservation biology into the development of automated vehicle technology to reduce animal-vehicle collisions. Conservation letters*, 2018, p. 2017-2018.

- O'Brien E. et al., *Contractor report 2018-3 call 2013: Roads and wildlife - The roads and wildlife manual*, 2018, 131 p.
- Office fédéral de l'environnement, des forêts et du paysage (OFEFP), N° 326 : *Les corridors faunistiques en Suisse*, *Cahier de l'environnement*, 2001, 118 p.
- Olsson M., Balot K. & Lindqvist M., *Ecoduct Sandsjöbacka - Challenges and solutions when constructing an ecoduct over an existing highway*, International conference IENE, 2018, 1 p.
- Olsson Mathias et al., *Effect of a retrofitted protection screen on wildlife use of an underpass in Southern Sweden*, International conférence IENE, 2018, 1 p.
- Olsson M., Seiler A., *The use of a moose and roe deer permeability index to develop performance standards for conventional road bridges*, International conference IENE, 2012, 1 p.
- Olsson M. et al., *The use of an underpass in southern Sweden*, IENE conference, 2018, 1 p.
- Olsson M., Balot K., Lindqvist M., *Ecoduct Sandsjöbacka - Challenges and solutions when constructing an ecoduc over an existing highway*, IENE conference, 2018, 1 p.
- Patrick D. L., Mullan J. B., Paiewonsky L., *Design of bridges and culverts for wildlife passage at freshwater streams the commonwealth of Massachusetts*, 2010, 115 p.
- Pell S. & Jones D., *Are wildlife overpasses of conservation value for birds? A study in australian sub-tropical forest, with wider implications. Biological conservation*, 2015, p. 300-309.
- Pfister H. P. et al., *Bio-oekologische wirksamkeit von gruenbruecken ueber verkehrswege*, 1997.
- Pichard O. et al., *Critères éco-éthologiques à prendre en compte pour la restauration des continuités écologiques au droit des ouvrages de franchissement d'infrastructures de transport*, 2018, 171 p.
- Popp J. N. & Hamr J., *Seasonal use of railways by wildlife. Diversity*, 2018, p. 1-10.
- Reck H., Hänel K. & Huckauf K., *Nationwide priorities for ecosystem connectivity – Final report of the R & D project*, 2010, 24 p.
- Reck H., *Do we have a proper idea of how much investment for defragmentation is needed? Experiences about financial, spatial and temporal demands for effective connection of ecoducts by designing ecological corridors*, IENE International Conference, 2016, 1 p.
- Reck H., *Roadside vegetation and biological diversity: potential and reality*, 2018, 5 p.
- Reck H., Rietze J. & Herman G., *Zöologische untersuchungen an den grünbrücken württemberg*, 1987, p. 469-492.
- Reck H. et al., *Green bridges, wildlife tunnels and fauna culverts the biodiversity approach*, *BfN-Skripten 522*, 2019.
- Reck H. & Nissen H., *Laufkäfer auf der autobahn - die laufkäferfauna (carabidae) eines autobahnmittelstreifens und einer benachbarten grünbrücke. Faunistisch-Ökologische Mitteilungen*, 2014, p. 371-384.
- Reck H. & Van Der Ree R., *Insects, snails and spiders: the role of invertebrates in road ecology. Handbook of Road Ecology*, 2015, p. 247-257.
- Redon de Colombier L., *Intérêts écologiques des bords de route en milieu agricole intensif. Thèse de doctorat, Muséum national d'histoire naturelle, E.D. 227, Sciences de la nature et de l'homme*, 2008, 190 p.
- Remon J., Chevallier E. & Moulherat, S., *Functional connectivity of biodiversity across an accumulation of large-scale transportation infrastructures in the South-West of France*, IENE International Conference, 2016, 1 p.
- Riginos C. et al., *Wildlife warning reflectors and white canvas reduce deer-vehicle collisions and risky road-crossing behavior*, *Wildlife society bulletin*, 2018, p. 119-30.

- Righetti A. et al., *Faunagerechte sanierung von bestehenden gewässerdurchlässen*, 2008, 92 p.
- Rodríguez A., Crema G., Delibes M., *Factors affecting crossing of red foxes and wildcats through non-wildlife passages across a high-speed railway*, *Ecography*, 1997, p. 287-94.
- Rondinini C., Doncaster C. P., *Roads as barriers to movement for hedgehogs. Functional ecology*, 2002, p. 504-509.
- Rosell C., *Road maintenance practices to improve wildlife conservation and traffic safety*, IENE International Conference, 2014, 64 p.
- Rosell C. et al., *Bats and invertebrates provide evidence of ecoducts' role as key elements of the green infrastructure*, IENE International Conference, 2016, p. 1-12.
- Ruediger B., DiGiorgio M., *Safe passage - A user's guide to developing effective highway crossings for carnivores and other wildlife*, 2009, p. 19-23.
- Ruediger W., Jacobson S., *Multiple-use crossing structures for providing wildlife habitat connectivity. Proceedings of the 2013 International Conference on Ecology and Transportation*, Icoet, 2013, 14 p.
- Ruffrey V., Breaud J.-F., *DEAL Guyane RN 2 : réalisation de ponts de singe au droit de couloirs écologiques*, 2013, 6 p.
- Rytwinski T. et al., *How effective is road mitigation at reducing road-kill? A meta-analysis*, *PLoS ONE*, 2016, p. 1-25.
- Rytwinski T. et al., *Experimental study designs to improve the evaluation of road mitigation measures for wildlife. Journal of environmental management*, 2015, p. 48-64.
- Scher O., *Les bassins d'eau pluviale autoroutiers en région Méditerranéenne : Fonctionnement et Biodiversité. Évaluation de l'impact de la pollution routière sur les communautés animales aquatiques. Thèse de doctorat, Université de Provence, E.R. Biodiversité & Environnement*, 2005, 130 p.
- Schmellekamp C., Tegethof U., *Viability of linking bridges in the area of environmental corridors*, IENE International Conference, 2016, 1 p.
- Seidler R. G., Green D. S. & Beckmann J. P., *Highways, crossing structures and risk: behaviors of greater yellowstone pronghorn elucidate efficacy of road mitigation*, *Global ecology and conservation*, 2018, 10 p.
- Seiler A., Olsson M., *Are non wildlife underpasses effective passages for wildlife?*, 2005, p.317-331.
- Seiler A., *Ungulate-train collisions in sweden - review, gis-analyses and train - Drivers experiences*, 2011, 85 p.
- Seiler A. & Bhardwaj M., *Wildlife and traffic: an inevitable but not unsolvable problem?*, *Problematic wildlife*, 2020, p. 171-190.
- Seiler A., Klein J. & Chapron G., *Barriers or bridges: simulating effects of road mitigation on population viability*, IENE International Conference, 2016, 13 p.
- Seiler A. et al., *Cost-benefit analyses for wildlife and traffic safety. Technical report*, 2016, 60 p.
- SETRA, *Passage pour la grande faune - Guide technique*, 1993, 70 p.
- SETRA, *Aménagements et mesures pour la petite faune*, 2005, 247 p.
- SETRA, *Fauchez mieux, le fauchage raisonné. Note d'information du Sétra - Série Chaussées Dépendance n°122*, 2009, p. 1-24.
- Shilling F., *Wildlife-vehicle conflict hotspots along California highways (2009-2015): Carcasses*, 2016, 11 p.
- Shilling F. et al., *Vermont's best management practices for highways & wildlife connectivity*, 2012, p. 1-144.
- Simpson N. O. et al., *Overpasses and underpasses: effectiveness of crossing structures for migratory ungulates. Journal of wildlife management*, 2016, p. 1370-378.

- Smith D. J., Van Der Ree R. & Rosell C., *Wildlife crossing structures: an effective strategy to restore or maintain wildlife connectivity across roads*, *Handbook of Road Ecology*, 2015, p. 172-183.
- Soga A. et al., *Relationship between spatial distribution of sika deer-train collisions and sika deer movement in japan*. *Human-wildlife interactions*, 2015, p. 198-210.
- Sordello Romain, *Bilan technique sur la première génération des schémas régionaux de cohérence écologique - Prise en compte des enjeux de cohérence issus des orientations nationales*, *Centre de ressources Trame verte et bleue (MTES)*, 2017, 152 p.
- Sordello R. (coord.), *Construire des indicateurs nationaux sur la pollution lumineuse. Réflexion préliminaire*, UMS PatriNat, Cerema, CESCO, DarkSkyLab, IRD, Irstea, 2018, 47 p.
- Sordello R., Conruyt-Rogéon G. & Touroult J., *La fonctionnalité des continuités écologiques - Premiers éléments d'illustration et de compréhension*, 2014, 33 p.
- Sordello R. et al., *Le changement climatique et les réseaux écologiques. Point sur la connaissance et pistes de développement*, 2014, 178 p.
- Sordello R. et al., *Trame Noire : un sujet qui « monte » dans les territoires*, *Sciences Eaux & Territoires*, 2018, p. 78-85
- Sordello R. et al., *Effet fragmentant de la lumière et impacts sur le déplacement des espèces*, 2014, 32 p.
- Sorolla A. et al., *Monitoring wildlife crossing structures in Catalonia's road network*, IENE International Conference, 2016, 1 p.
- Stewart K. M., *Effectiveness of wildlife crossing structures to minimize traffic collisions with mule deer and other wildlife in Nevada*, 2015, p. 1-34.
- Surowiecki A. & Bujak A., *Environmental protection solutions in the process of modernisation of the polish railways*, 2013, p. 93-111.
- Tissier M.L. et al., *An anti-predation device to facilitate and secure the crossing of small mammals in motorway wildlife underpasses*. *Ecological Engineering*, 2016, p. 738-742.
- Trocmé M., Righetti A., Wegelin A., *Ouvrages de franchissement pour la faune - Directive - ASTRA 18008*. OFFROU, 2014, 40 p.
- UICN, France, *Corridors d'infrastructures, corridors écologiques ? État des lieux et recommandations*, 2015, p. 1-37.
- Valitzki S.A. et al., *Deer responses to sounds from a vehicle-mounted sound-production system*. *Journal of wildlife management*, 2009, p. 1072-1076.
- Van der Grift E.A. et al., *Multiuse overpasses: does human use impact the use by wildlife?*, 2011, p. 115-123.
- Van Der Grift E.A. & Van Der Ree R., *Guidelines for evaluating use of wildlife crossing structures*. *Handbook of Road Ecology*, 2015, p. 119-128.
- Van der Grift E., Fabrice O. & Snep R., *Monitoring wildlife overpass use by amphibians: do artificially maintained humid conditions enhance crossing rates?*, ICOET, 2009, p. 341-347.
- Van Der Ree R., Gagnon J.W. & Smith D.J., *Fencing : a valuable tool for reducing wildlife-vehicle collisions and funnelling fauna to crossing structures*, *Handbook of Road Ecology*, 2015, p. 159-171.
- Van Der Ree R. & Van Der Grift E.A., *Recreational co-use of wildlife crossing structures*. *Handbook of Road Ecology*, 2015, p. 184-89.
- Van Der Ree R., Smith D.J., Grilo C., *Handbook of Road Ecology*, Wiley-Blackwell ed., 2015.
- Van Der Ree R., Van Der Grift E.A., Estacio C.M., *Overcoming the barrier effect of roads - how effective are mitigation strategies ? An international review of the use and effectiveness of underpasses and overpasses designed to increase the permeability of roads for wildlife*, 2007, 15 p.

- Vanpeene S. (coord.), *Prise en compte des orientations nationales pour la préservation et la remise en bon état des continuités écologiques par les grandes infrastructures linéaires de l'État et de ses établissements publics - Troisième document en appui à la mise en œuvre de la Trame verte et bleue en France. Proposition issue du comité opérationnel Trame verte et bleue*, MEEDM ed., 2010, 94 p.
- Veenbaas G. and Brandjes J., *Use of fauna passages along waterways under highways. Proc. Third Int. Conf. Wildl. Ecol. Transp.*, 1999, p. 253-258.
- Vignon V. & H. Barbarreau, *Les collisions entre véhicules et ongulés sauvages : quel coût économique ?*, *Faune Sauvage* 279, 2008, p. 31-35.
- Vignon V. & Suez M., *Structuration spatiale des populations de cerfs élaphe autour de Paris : quels rôles des infrastructures de transport ?*, 2016, p. 60-67.
- Villemey A. et al., *Can linear transportation infrastructure verges constitute a habitat and/or a corridor for insects in temperate landscapes? A systematic review. Environmental evidence*, 2018, p. 1-33.
- Vinci Autoroutes, *Use by large mammals of wildlife crossing structure on an overpass in Western France results of the first three years of camera-trap surveys*, Colloque IENE, 2016, 9 p.
- Vinci Autoroutes, *Video : Préservation de la biodiversité : les ouvrages réalisés par Vinci Autoroutes*, <https://www.youtube.com/watch?v=xCyW6Vklcx-8&t=43s>, 2019.
- Wang J., *Effectiveness of wildlife crossing structures on providing habitat connectivity for wild animals*, *Forest Resource Management. The Faculty of Forestry*, 2014, 20 p.
- Wansink D.E.H. et al., *Leidraad faunavoorzieningen bij infrastructuur (Rijkswaterstaat & ProRail)*, 2013, 122 p.
- Ważna A. et al., *Use of underpasses by animals on a fenced expressway in a suburban area in Western Poland. Nature conservation*, 2020, p. 1-18.
- White I.C. & Hughes S.A., *Trial of a bridge for reconnecting fragmented arboreal habitat for hazel dormouse muscardinus avellanarius at Bridesford nature reserve, Isle of Wight, UK, Conservation evidence*, 2019, p. 6-11.
- Woess M., Grillmayer R. & Voelk F.H., *Green bridges and wildlife corridors in Austria*, 2002, p. 25-32.
- Wojciech J., *Small mammal use of modified culverts on the Lolo South project of Western Montana - an update*, ICOET 2003, p. 1-4.
- Work R., *Wildlife vehicle collision be decreased by increasing the number of wildlife passages in*, 2007, p. 392-400.
- Yanes M., Velasco J. M. & Suárez F., *Permeability of roads and railways to vertebrates: the importance of culverts. Biological conservation*, 1995, p. 217-222.
- Zlatanova D. et al., *Recommendations for the reduction of habitat fragmentation caused by transport infrastructure development*, 2010, 195 p.

Table of contents

■ Preamble 11

P A R T I

■ The ecological network and land transport infrastructure 14

FACT SHEET 1.	What is an ecological network?	16
	A land-use planning tool	16
	An ecological reality essential to the conservation of species	18
FACT SHEET 2.	What methods can be used to identify the ecological network?	22
	Identification of biodiversity reservoirs*	23
	Identification of ecological corridors	24
	Special case of the black grid*	26
FACT SHEET 3.	Why should the ecological network be taken into account as part of a linear transport infrastructure project?	28
	A regulatory requirement	28
	An ecological necessity (fragmentation, wildlife vehicle collision)	29
	The imperative of passenger safety	40
FACT SHEET 4.	How to provide an effective response to the disruption of the ecological network?	42
	Re-establishing transversal and longitudinal continuities	42
	Integrating the ecological network during the different stages of the project	43
	Ensure good social acceptance of fauna passages	55

P A R T II

■ Fauna passages: an effective measurement to re-establish transversal connectivities 58

1.	Fauna passages on new infrastructure projects	62
1.1.	All fauna passages	64
FACT SHEET 5.	Where to build an all fauna passage*?	66
	As a priority, on high-issue ecological networks	66
	In ordinary habitats to provide sufficient overall permeability	70
	Localisation taking into account technical constraints and other restoration structures	71
FACT SHEET 6.	What type of all fauna passage should be chosen?	77
	Overpass or underpass: a choice defined according to the lengthwise profile	77
	Mixed or dedicated passage: a choice depending on the level of restoration issues and the possibility of complementarity with another use	83
FACT SHEET 7.	How to size the passage?	90
	Width depending on the importance of the continuities to be restored and whether the passage is mixed or not	91

	Width depending on the length of the crossing	98
	For certain situations, prefer two smaller sized passages to a larger sized passage	99
	Width depending on the presence of target with a specific issue	100
FACT SHEET 8.	How to design and develop all fauna passages?	106
	Development of overpasses	106
	Development of underpasses	120
	Development of immediate surroundings	124
	Beyond the immediate surroundings	131
FACT SHEET 9.	What are the different types of construction?	
	At what cost?	133
	Type of materials	133
	Type of construction	134

1.2.	Passages and developments for small fauna	136
FACT SHEET 10.	Where to build small fauna passages?	137
	A basic rule: a passage possibility every 300m	137
	Consideration of all crossing possibilities	138
FACT SHEET 11.	How to develop small waterway structures for small fauna?	140
	Mixed small fauna structures/restoration of a watercourse or ditch	140
	Waterway structures associated with a dry conduit	151
	Temporary flow restoration waterway structures for dry talwegs	152
FACT SHEET 12.	How to develop agricultural/forest/pedestrian structures for small fauna?	154
FACT SHEET 13.	How to develop specialised passages amphibian passage - tree canopy passage)?	156
	Amphibian passages or "batrachian tunnels"	156
	Canopy passage	164
FACT SHEET 14.	How to develop common small fauna passages?	165
	Types and sizes of passages	165
	Conditions for installation	167
	Additional developments	172

2.	On existing infrastructure - Upgrading	178
2.1.	Development and/or upgrading of existing structures	179
FACT SHEET 15.	How to improve the functionality of existing fauna passages?	180
	Reinforcement of planting, removal of light pollution	180
	Widening of overpasses	181
FACT SHEET 16.	How to promote the passage of small fauna on existing structures not dedicated to fauna?	183
	Development of grass verges for small fauna on or in low traffic structures (agricultural, forestry, etc.)	183
	Transformation of a non-dedicated structure into an all fauna passage	185
	Creation of a small fauna bench in existing waterway structures (corbelled, natural bench, etc.)	186
	Continuity restoration in hydraulic discharge structures equipped with a water ditch	195

2.2.	Construction of new structures on existing infrastructure	196
FACT SHEET 17.	Where and how to build an all fauna passage on existing infrastructure?	197
FACT SHEET 18.	How to create a small fauna passage on existing infrastructure?	199
	By boring or microtunnelling	199
	By opening the lane	201
	By installing a canopy passage	204
2.3.	Other developments	205
FACT SHEET 19.	What are the warning systems (fauna and/or vehicles) set up to reduce wildlife vehicle collisions?	206
	Reflecting surfaces	206
	Acoustic devices	207
	Driver information systems	208
	Mixed driver information systems and wildlife warning systems	209
	Embedded systems	210

P A R T III

- **Green rights-of-way: supporting longitudinal continuities** **212**

FACT SHEET 20.	How to integrate biodiversity into the design of rights-of-way?	217
	Modelling of roadsides favourable to biodiversity*	217
	Favourable vegetation development	219
	Increase in the number of habitats	220
	Adapted management	221
FACT SHEET 21.	How to ensure fauna's access to rights-of-way while ensuring its protection? Fences and barriers	227
	The conditions for the installation of fences and barriers along rights-of-way	227
	Types of fences or barriers depending on the series of species	243

P A R T IV

- **How to ensure the long-term efficacy of measures: maintenance, monitoring** **254**

FACT SHEET 22.	How to maintain fauna passages?	256
	A few regulatory reminders	256
	Maintenance of the structure and its immediate surroundings	257
	Maintenance of green rights-of-way	258
FACT SHEET 23.	How should fauna passages be monitored?	260
	Some general points, regulatory and methodological reminders	260
	Monitoring the efficacy of a measure	261

- **Glossary** **267**

- **List of abbreviations** **275**

- **Bibliography** **279**

Les passages à faune

Préserver et restaurer les continuités écologiques avec les infrastructures linéaires de transport

L'érosion de la biodiversité s'accélère en France comme ailleurs. La France est le 5^e pays d'Europe abritant le plus grand nombre d'espèces de faune et de flore mondialement menacées. Parmi les causes de destruction de la biodiversité figurent la disparition et la fragmentation des écosystèmes induites par les infrastructures de transport terrestre telles que les autoroutes ou les LGV. La diminution de l'impact de ces infrastructures sur la biodiversité passe par le maintien des continuités écologiques existantes lors de la conception de nouveaux projets mais aussi par la restauration des fonctionnalités écologiques anciennement interrompues lors de la construction des infrastructures existantes. Les solutions étudiées prennent notamment la forme de passages à faune ou d'aménagement de dépendances vertes. Très richement illustré, ce guide très complet a pour objet d'aider et de faciliter la prise en compte de ces enjeux lors des différents projets d'aménagement d'infrastructures linéaires de transport. Il constitue notamment une réactualisation des anciens guides de référence *Passages pour la grande faune*, SETRA, 1993 et *Aménagements et mesures pour la petite faune*, SETRA, 2005. Il s'adresse aux opérateurs d'infrastructures mais plus largement à ceux qui sont concernés par la préservation de la biodiversité dans un contexte de développement des infrastructures de transport.

Los pasos para la fauna

Preservar y restaurar las continuidades ecológicas en los proyectos de infraestructuras lineales de transporte

La erosión de la biodiversidad se acelera en Francia, al igual que en el extranjero. Francia es el 5^{to} país de Europa que alberga la mayor cantidad de especies de fauna y flora mundialmente amenazadas. Entre las causas de destrucción de la biodiversidad figuran la desaparición y la fragmentación de los ecosistemas inducidos por las infraestructuras de transporte terrestre como son las autopistas o las líneas de alta velocidad. La disminución del impacto de estas infraestructuras sobre la biodiversidad pasa por el mantenimiento de las continuidades ecológicas existentes al diseñar nuevos proyectos, así como por la restauración de las funcionalidades ecológicas interrumpidas en el pasado al construir las infraestructuras existentes. Las soluciones estudiadas en particular tomarán la forma de pasos para la fauna o acondicionamientos de dependencias verdes. Muy ricamente ilustrada, esta guía muy completa tiene por objeto ayudar y facilitar la toma en consideración de estos retos al realizar diferentes proyectos de acondicionamiento de infraestructuras lineales de transporte. En particular, constituye una reactualización de las antiguas guías de referencia *Pasos para la fauna mayor*, SETRA, 1993 y *Acondicionamientos y medidas para la fauna menor*, SETRA, 2005. Está dirigida a los operadores de infraestructuras, pero más ampliamente a los que están concernidos por la preservación de la biodiversidad en un contexto de desarrollo de las infraestructuras de transporter.

© 2023 - Cerema

Cerema: public expertise for the ecological transition and regional planning

Cerema (Centre d'études et d'expertise sur les risques, l'environnement, la mobilité et l'aménagement – Centre for Studies on Risks, the Environment, Mobility and Urban Planning), is a public institution that assists government and local authorities in the development, implementation and evaluation of public policies for the ecological transition, adaptation to climate change and regional cohesion. It performs research and innovation activities, while also helping to share innovations with the regions and private operators.

Cerema operates in six main areas: Expertise & Regional Engineering, Construction, Mobility, Transport Infrastructures, Environment & Risks, Sea & Coast. With 26 locations across mainland France and the French overseas territories, it develops leading expertise in conjunction with European partners, and helps disseminate France's know-how on an international scale.

Cerema capitalises on knowledge and expertise in its various fields of activity. As a publisher, it acts as an engineering resource centre, making some 3,000 references available on the www.cerema.fr website under "Our editions".

No part of this document may be reproduced without prior permission from Cerema (Article L.122-4 of the French Intellectual Property Code (CPI)). Any such reproduction, carried out by whatever means, will be considered as counterfeit and will be liable for prosecution under articles L.335-2 and L.335-3 of the CPI.

This publication is printed on paper sourced from sustainably managed (PEFCcertified) forests and manufactured in an environmentally friendly manner (using ECF technology). Dupliprint is a printing plant that is recognised for its efforts to protect the environment and that respects all European directives in force relating to the use of vegetable-based inks, the recycling of waste paper, the treatment of dangerous waste via approved channels and the reduction of VOC emissions.

Printed by: Dupliprint – 733 rue Saint-Léonard – 53100 Mayenne – Tel. 02 43 11 09 00

Cover photo: "Planted eco-bridge" – © VINCI Autoroutes photograph library – Emmanuel Rondeau (photo amended and retouched by Cerema - removal of a company trademark on the tarpaulin of a truck)

Coordination: Cerema DSC/DDC/EVC (P. Marchand)

Layout: PAO Concept - pao.concept@free.fr

Printing completed: June 2023

Legal registration: June 2023

ISBN: 978-2-37180-610-8 (pdf)

ISBN: 978-2-37180-611-5 (paper)

ISSN: 2276-0164

Éditions du Cerema

Cité des Mobilités

25 Avenue François Mitterrand, CS 92803,

69674 Bron Cedex

To order or download our publications › www.cerema.fr

For all correspondence › bventes@cerema.fr - Tel. 04 72 74 59 59

FAUNA PASSAGES

Maintaining and restoring the ecological network with linear transport infrastructure

The erosion of biodiversity is picking up speed in France as it is elsewhere.

France is the European country with the fifth-highest number of globally threatened species of fauna and flora. The causes of biodiversity destruction include the disappearance and fragmentation of ecosystems brought about by land transport infrastructures such as motorways or high-speed railways. Reducing the impact of these infrastructures on biodiversity means maintaining the existing ecological network when designing new projects, as well as restoring ecological functions that have been interrupted during the construction of existing infrastructure. The solutions studied take the form of wildlife crossings or the development of green areas. This richly illustrated, comprehensive guide sets out to foster and facilitate consideration of these issues in different linear transport infrastructure development projects. In particular, it is an update of the former reference guides *Passages pour la grande faune*, SETRA, 1993 and *Aménagements et mesures pour la petite faune*, SETRA, 2005. It is intended for infrastructure operators and, more broadly, for all those concerned with the preservation of biodiversity in connexion with transport infrastructure development.



REGIONAL ENGINEERING | BUILDINGS | MOBILITY | TRANSPORT
INFRASTRUCTURES | ENVIRONMENT & RISKS | SEA & COAST

